

district

*Click on the desired Installation Guide to jump to the Guide page.

INDEX

By Section

Product Name	Product Code	Guide No.	Last Updated
POWER SPINE			
Power Spine Inset Panel	UYPZ	DIS_251a	Feb 2026
Spine Panel	UNPZ		
Support Kit	UZPK		
Power Spine Inset Panel	UYPZ	DIS_251b	Feb 2026
Spine Panel	UNPZ		
Support Kit	UZPK		
Power Spine 120 Hub Panel	UNYH	DIS_252	May 2026
Insert Panel	UZYH		
Support Kit	UZYK		
Power Spine 120 Hub Panel	UNZZ	DIS_253	May 2026
Insert Panel	UYZZ		
Support Kit	UZZK		
Floor Flush Power Spine	UNFF	DIS_254	May 2026
Floor Flush Inset Power Spine	UYFF		
Floor Flush Power Spine Support Kit	UZFF		
Open Frame 29"H Panel - Standard	UNAF	DIS_255	May 2026
Open Frame 29"H Panel - Inset	UYAF		
Sliding Fabric Screen for Open Frame	UNXF	DIS_256	May 2026
Sliding Smooth Felt Screen for Open Frame	UNZF		
120 Angled Worksurface	UZWA	DIS_257	Sept 2021
Support Bundle	UZWB		
120 Angled Worksurface	UZWE	DIS_258	May 2026
Support Bundle	UZWC		
Power Spine Rectangular Worksurface	UZWP	DIS_259	May 2026
Support Bundle	UZWK		
Parallelogram Worksurface	UZWT	DIS_260	Sept 2021
Support Bundle	UZWW		
Dual 120 Angled Worksurface	UZWD	DIS_261	May 2026
Support Bundle	UZDK		
hiSpace Quick Connect Height -Adjustable Freestanding Table	YSZ	DIS_262	May 2026
hiSpace Rectangular Worksurface	WBZ		
hiSpace Quick Connect 120 Hub HA Worksurface w\ Connection Kit	WBT	DIS_263	May 2026
120 Hub HA Mechanism	YST		
Parallelogram Freestanding Mechanism	YSB	DIS_264	May 2026
Parallelogram HA Worksurface	WBP		
Anchor for HA Table	UZAS	DIS_265	Sept 2024
Bracket Support for HA Table	UZBS	DIS_266	Sept 2024
Power Spine Base Feed Cover	UZBC	DIS_267	May 2026

District Power Spine Inset Panel (UYPZ), Spine Panel (UNPZ)
& Support Kit (UZPK)

UNPZ and UZPK shown

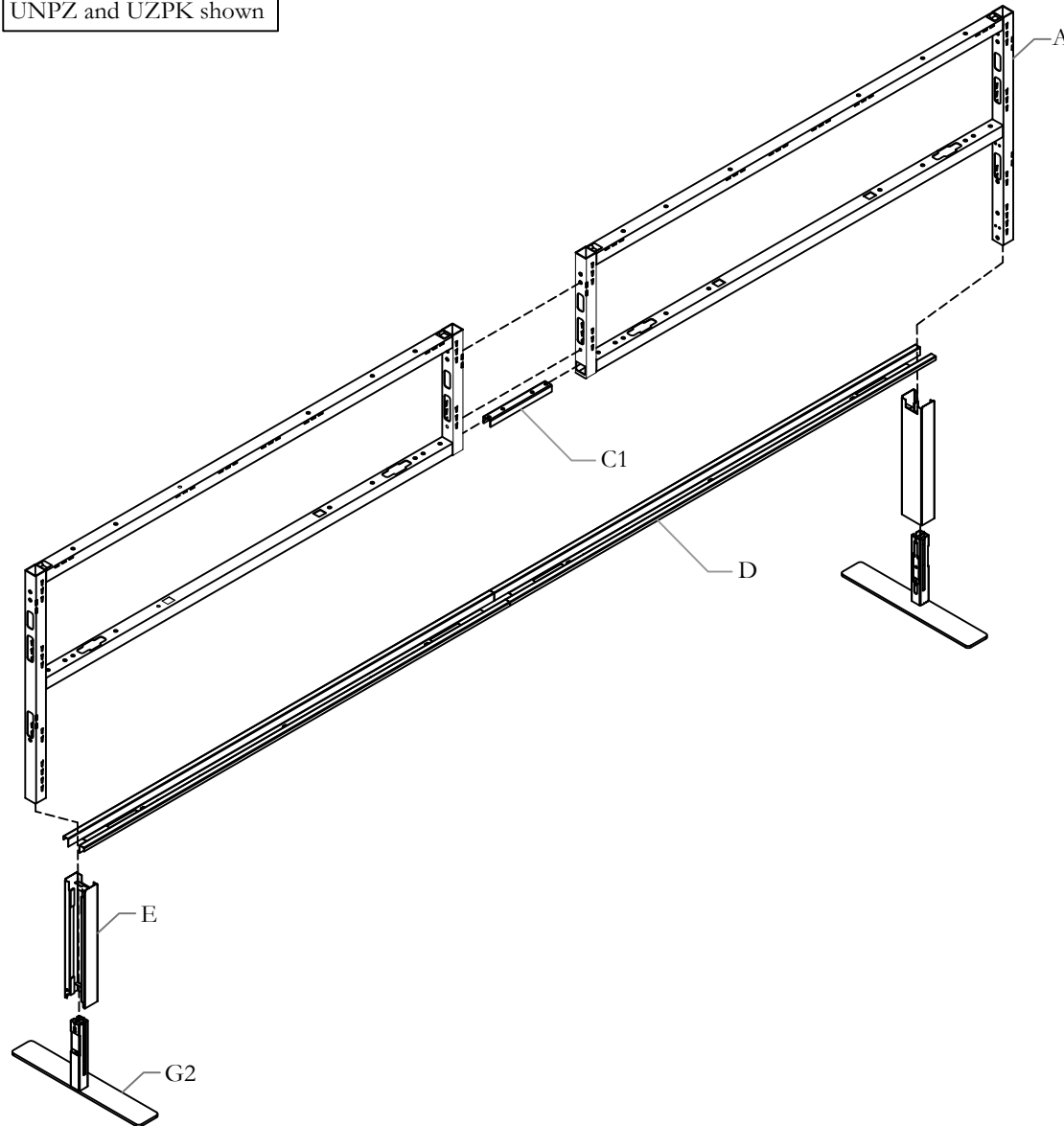

Part and Product Identification

	UYPZ	UNPZ
	A1 - Inset Elevated Power Spine Panel (N02-5541X-X) x varies	A2 - Standard Elevated Power Spine Panel (N02-5512X-X) x varies
B - (X01-1747) x varies		B1 - Hex Flange Locking Bolt 5/16-18x3.5-in Long Plate (E03-0430) x 1
		B2 - Flat Washer (E03-0457) x 2
		B3 - 5/16-18 Lock Nut Zinc Plate (E03-0437) x 1
C - (X01-3755) x varies		C1 - Bottom Splicer (N01-4667) x 1
		C2 - 5/16-18x3/4 Flanged Hex Cap Screw (E01-0997) x 4
		C3 - Flat Washer (E03-0457) x 4
		C4 - Pan Head Phillips (E01-1227) x 2
	D - Base Trim (A16-12160-X) x varies	
UZPK		E - Power Beam Leg Weldment (N01-4648) x varies
		F - #12x1" Tapping Screw (E07-0050) x varies
F - Foot Assembly (N02-5365\18, N02-5650\12, N02-5650\03) x varies		G1 - 5/16-18x3/4 Flanged Hex Cap Screw (E01-0997) x varies
		G2 - Power Beam Foot Assembly (N02-5365\18) x 2 (N02-5650\12) x varies

INSERT BOTTOM SPLICER

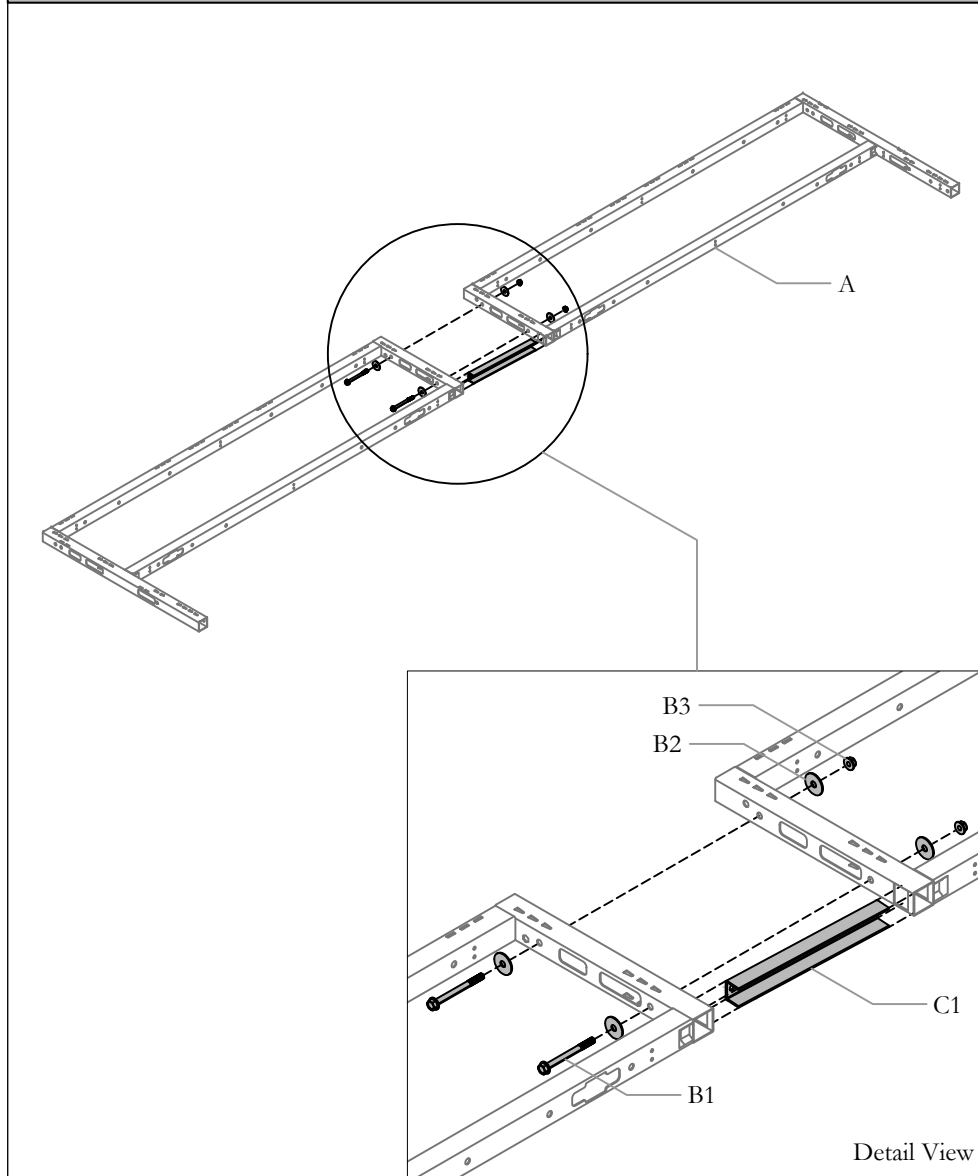

STEP 1: Lay down the Elevated Power Spine Panels (A) and align the holes. Insert the Bottom Splicer (C1) and secure with Bolts (B1), Washers (B2) and Nuts (B3) as shown.

FASTEN BOTTOM SPLICER

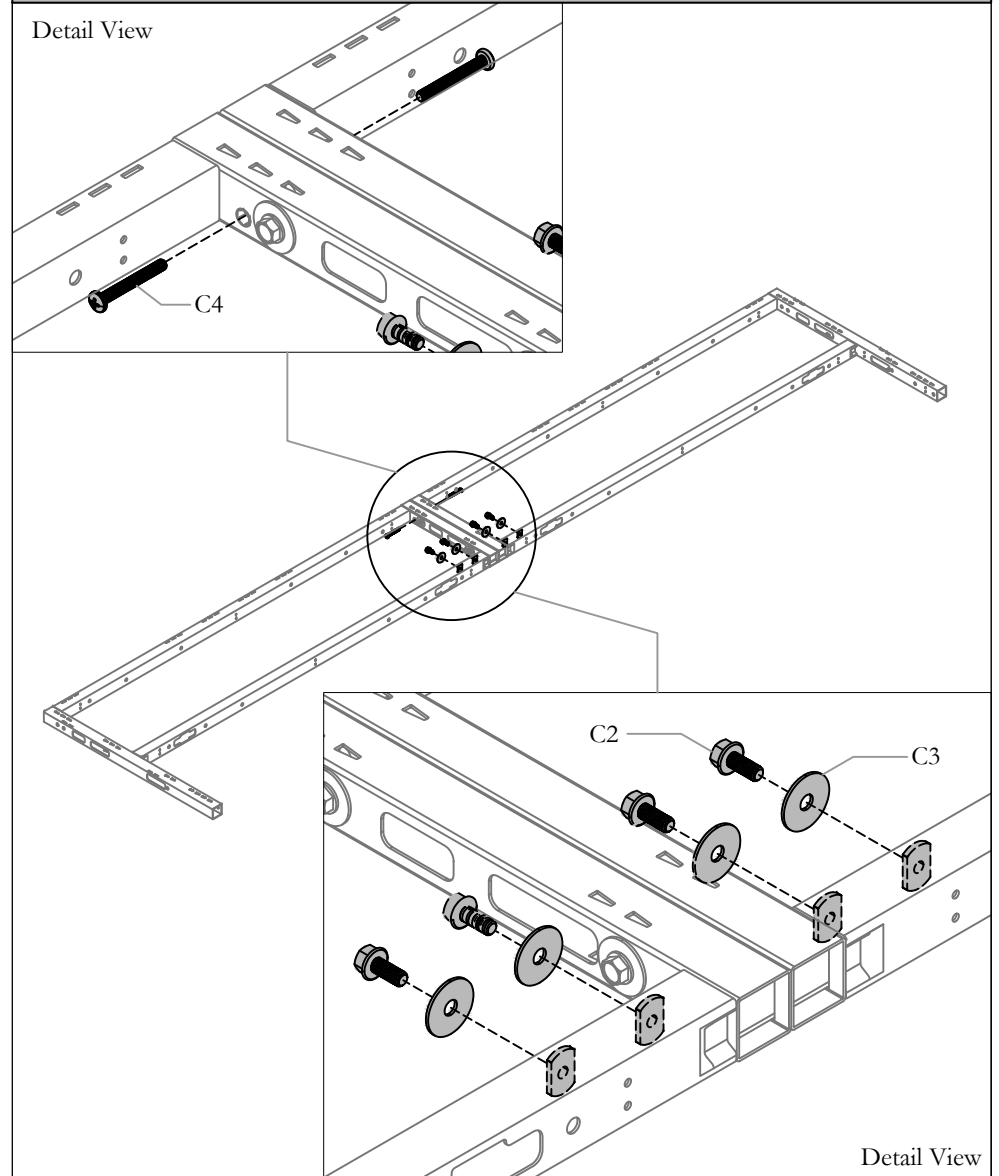

STEP 2: Fasten the Bottom Splicer to the Panels with Hex Screws (C2) and Washers (C3). Secure the frames with Screws (C4) as shown above.

INSTALL BASE TRIM

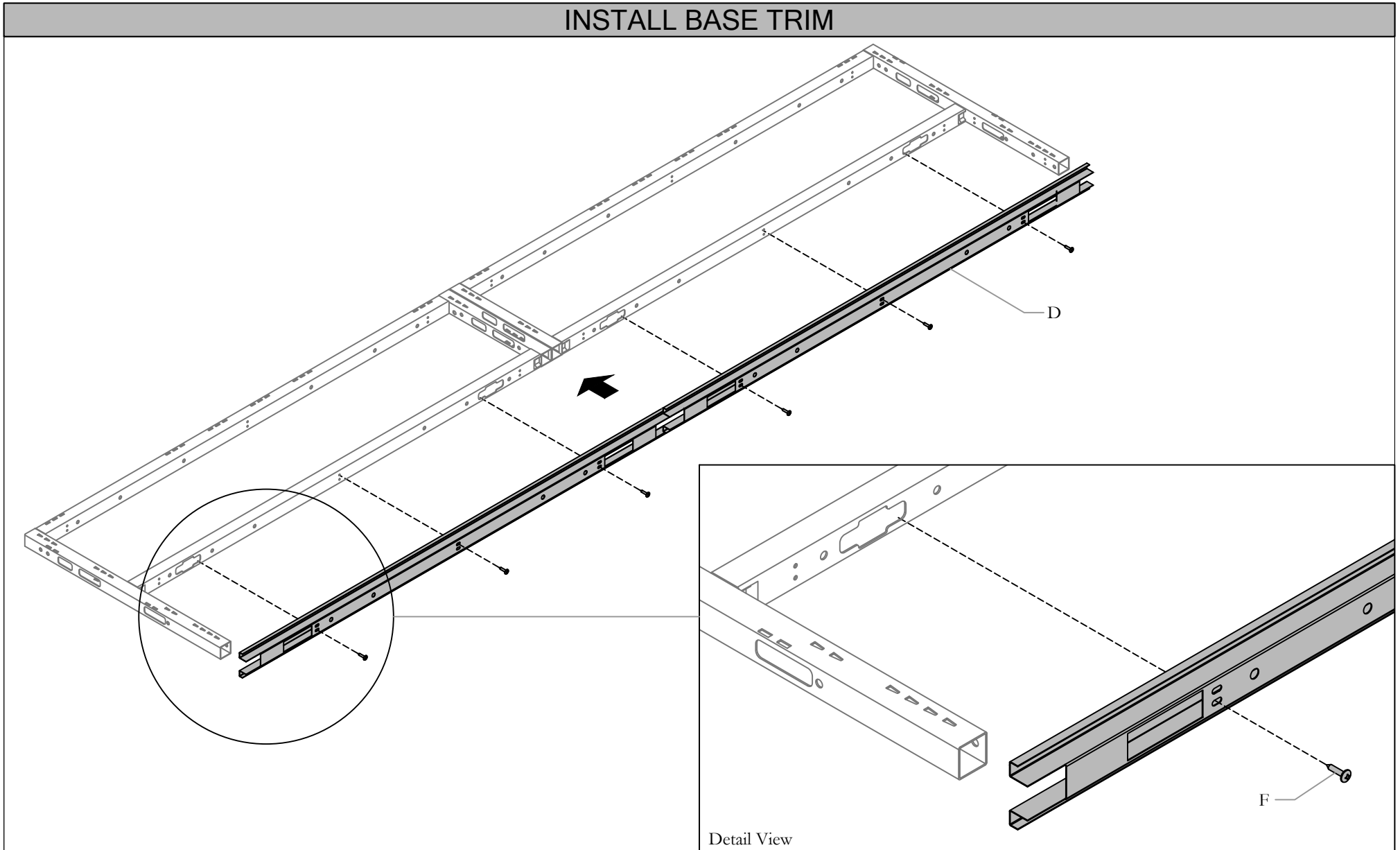

STEP 3: Place Base Trim (D) underneath the lower horizontal tube. Make sure the Base Trim is centered with respect to the frames. Secure the Base Trim in place with the Tapping Screws (F) included.

POWER BEAM FEET INSTALLATION (1)

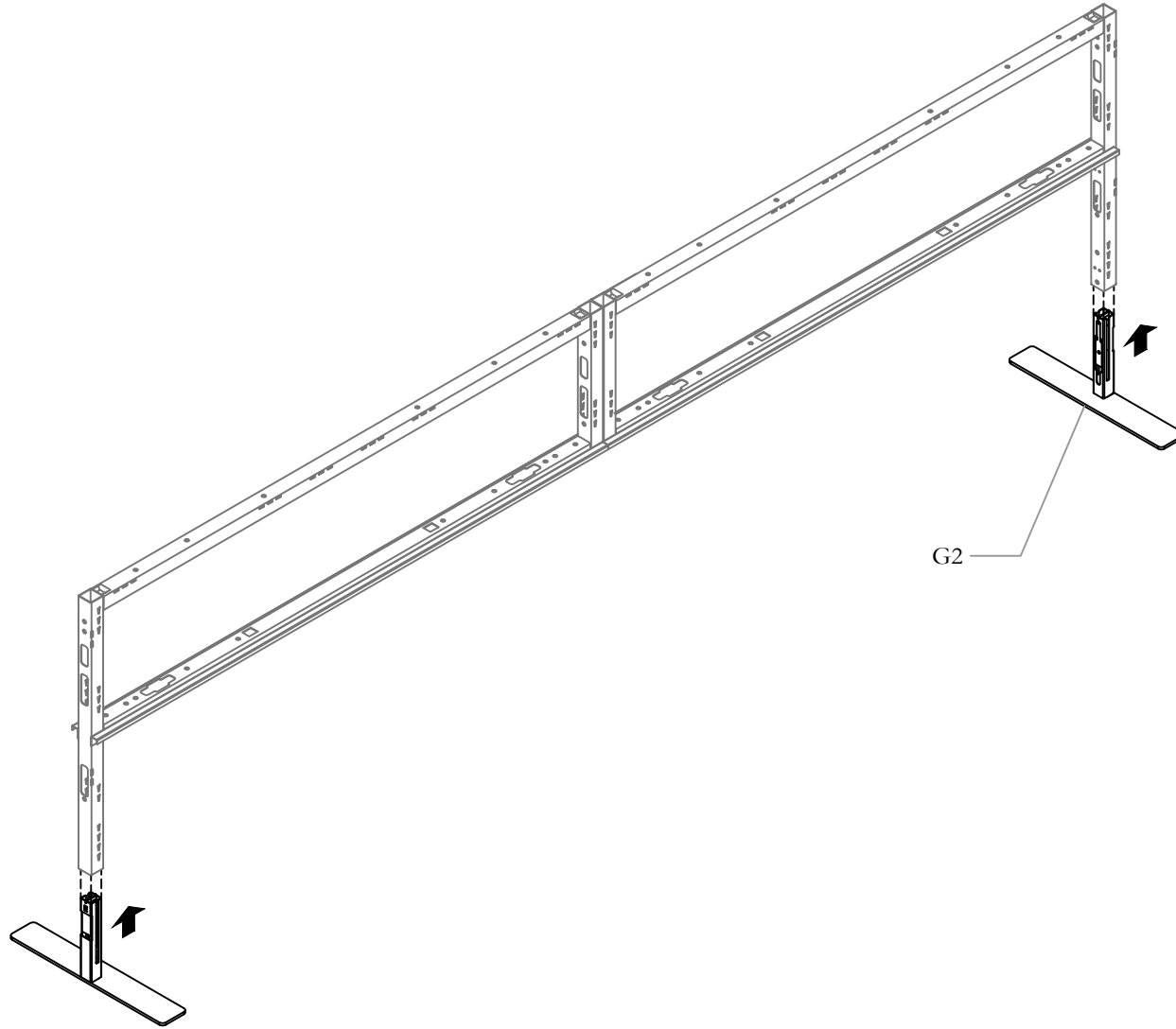

Outer Legs
(Left)

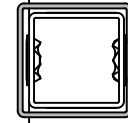

Outer Legs
(Right)

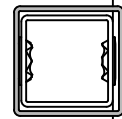

STEP 4: Slide the Power Beam Feet (G2) into the bottom of the Frames.

POWER BEAM FEET INSTALLATION (2)

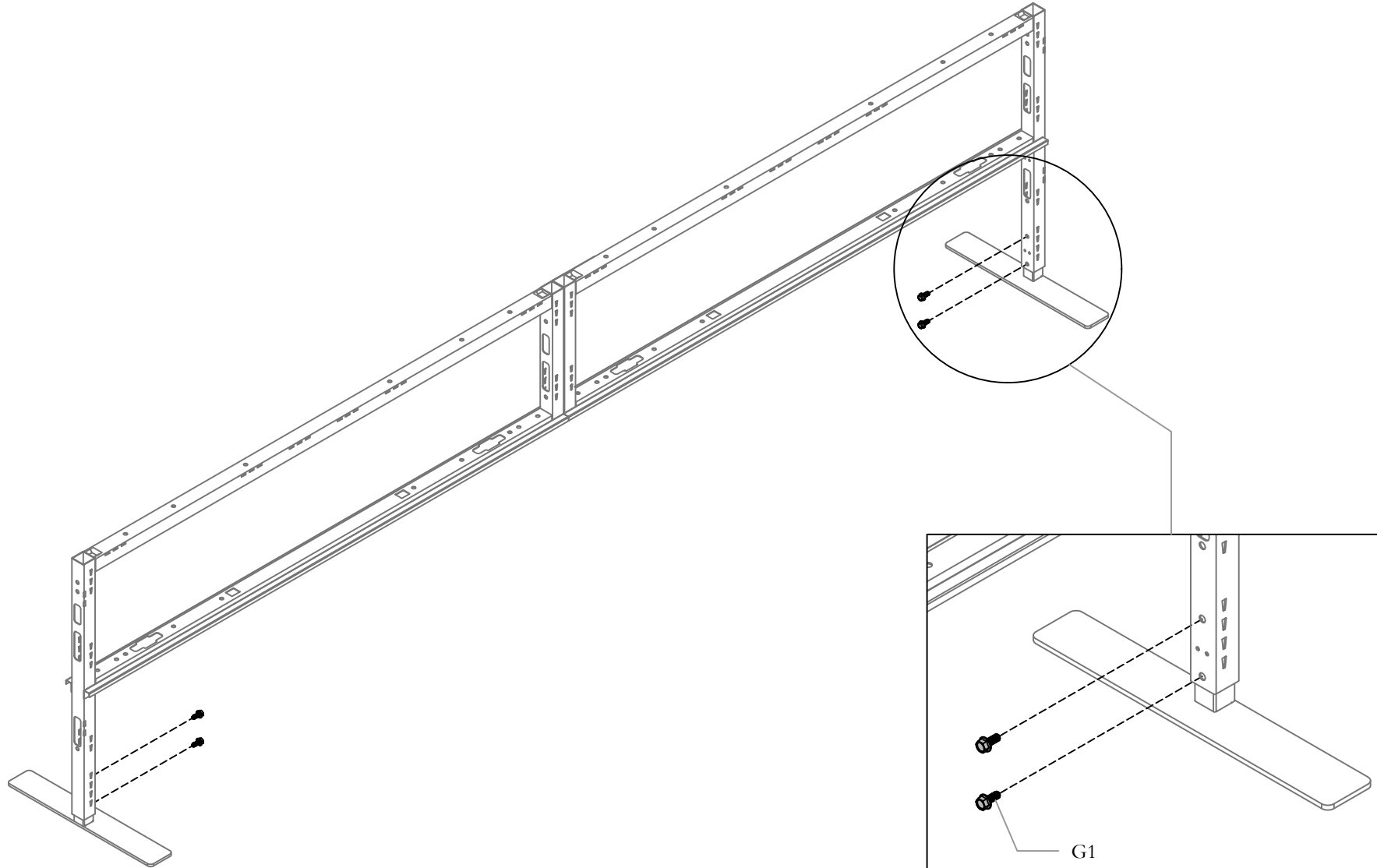

STEP 5: Level the whole Frames assembly, then fasten the Feet to the Frames using the Screws (G1) provided.

POWER SPINE PANEL LEVELING

NOTE: If the Frames' level are uneven, resulting in a dip, loosen the vertical bolts and tighten the screws to ensure the Frames are level before refastening the bolts and nuts.

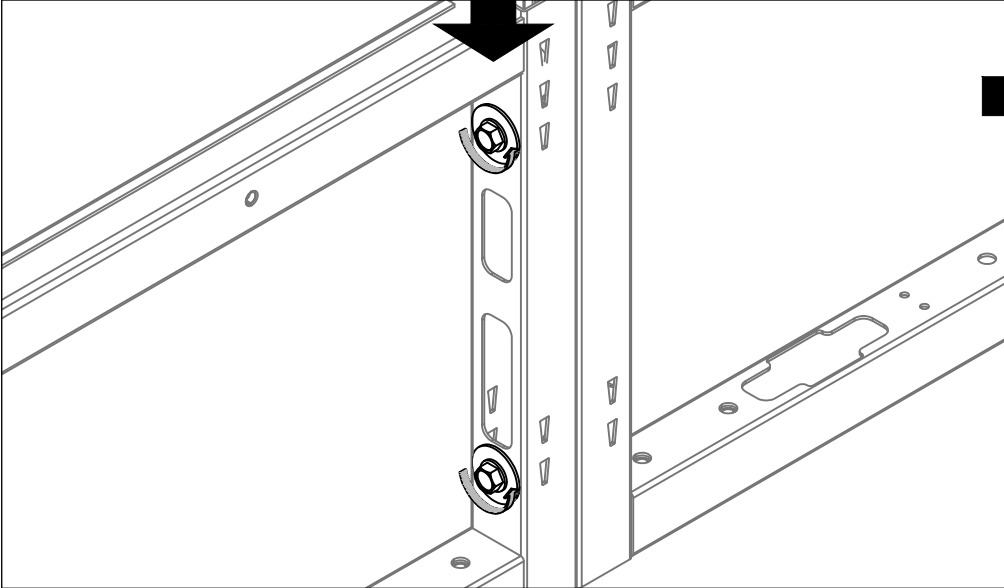
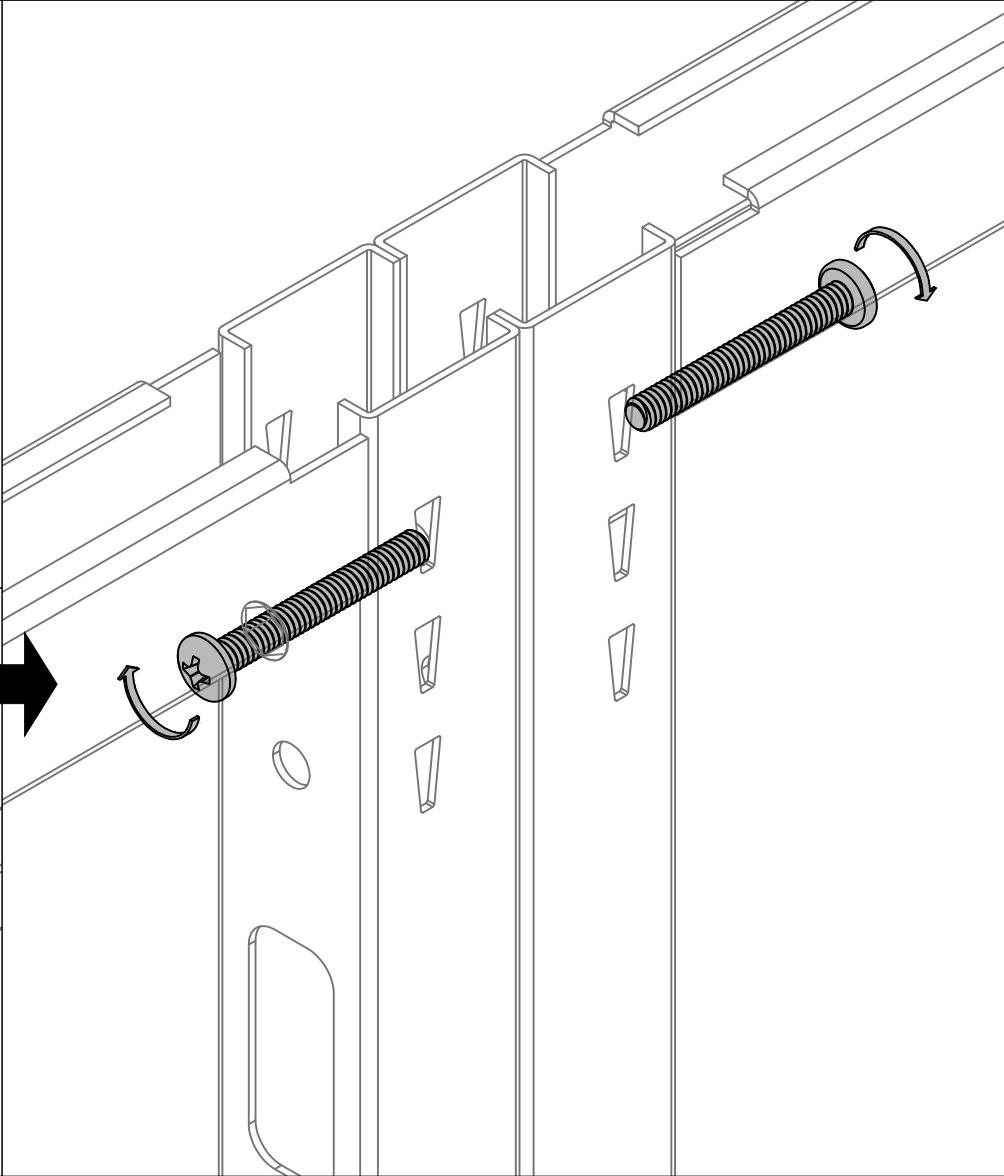
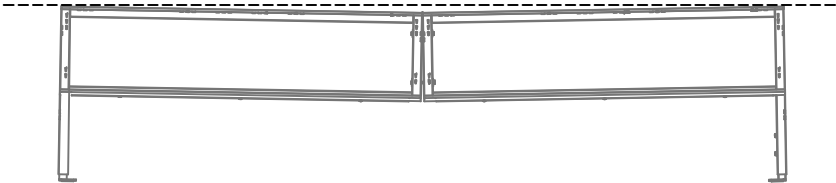

STEP 6: If the Frames' level are uneven, resulting in a dip, loosen the vertical bolts and tighten the screws to ensure the Frames are level before refastening the bolts and nuts.

ATTACH LEG COVER

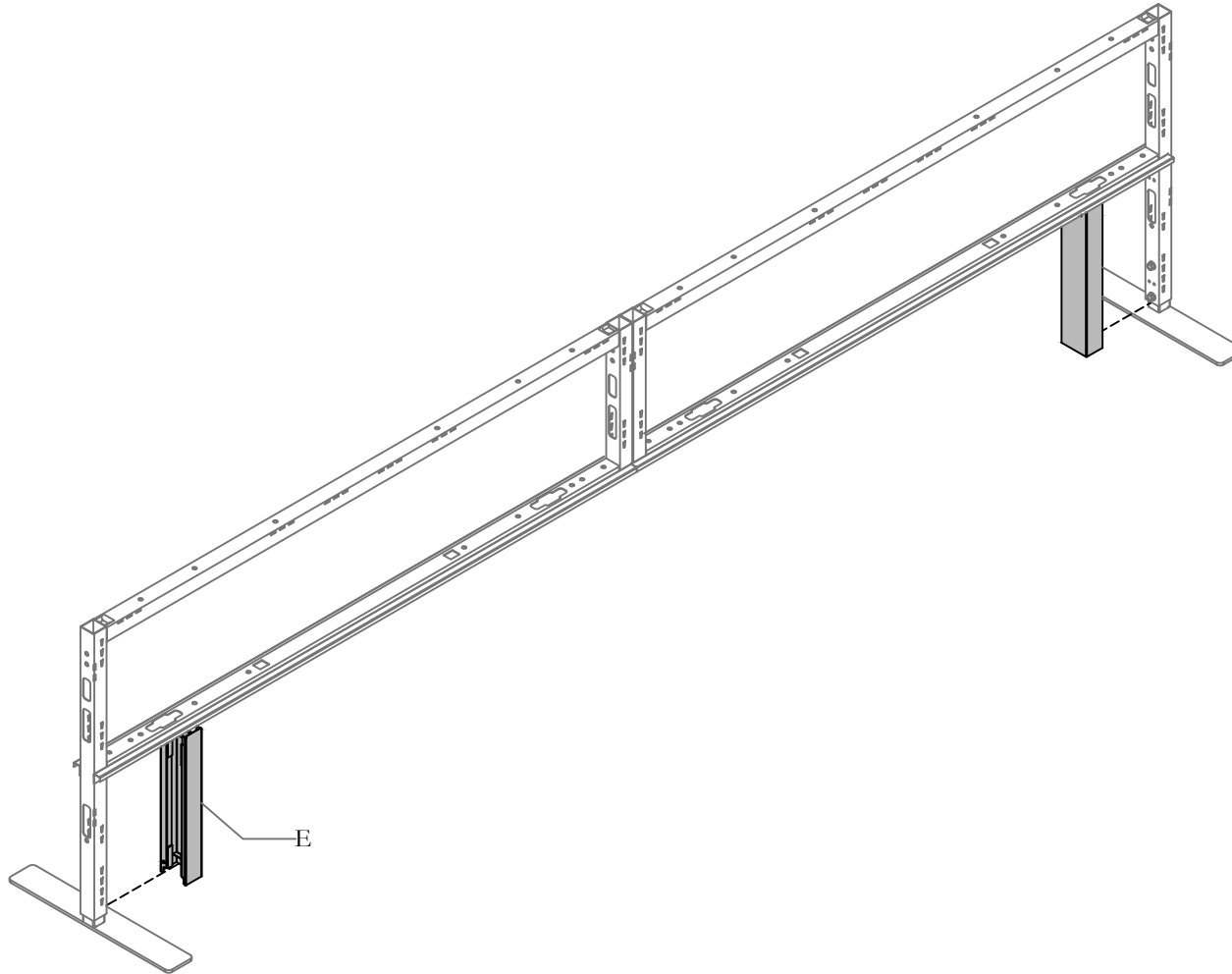

Outer Legs
(Left)

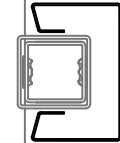

Outer Legs
(Right)

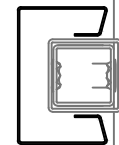

STEP 7: Align the Leg Cover (E) on both Frames, then place them as shown.

District Power Spine Inset Panel (UYPZ), Spine Panel (UNPZ)
& Support Kit (UZPK)

UNPZ and UZPK shown

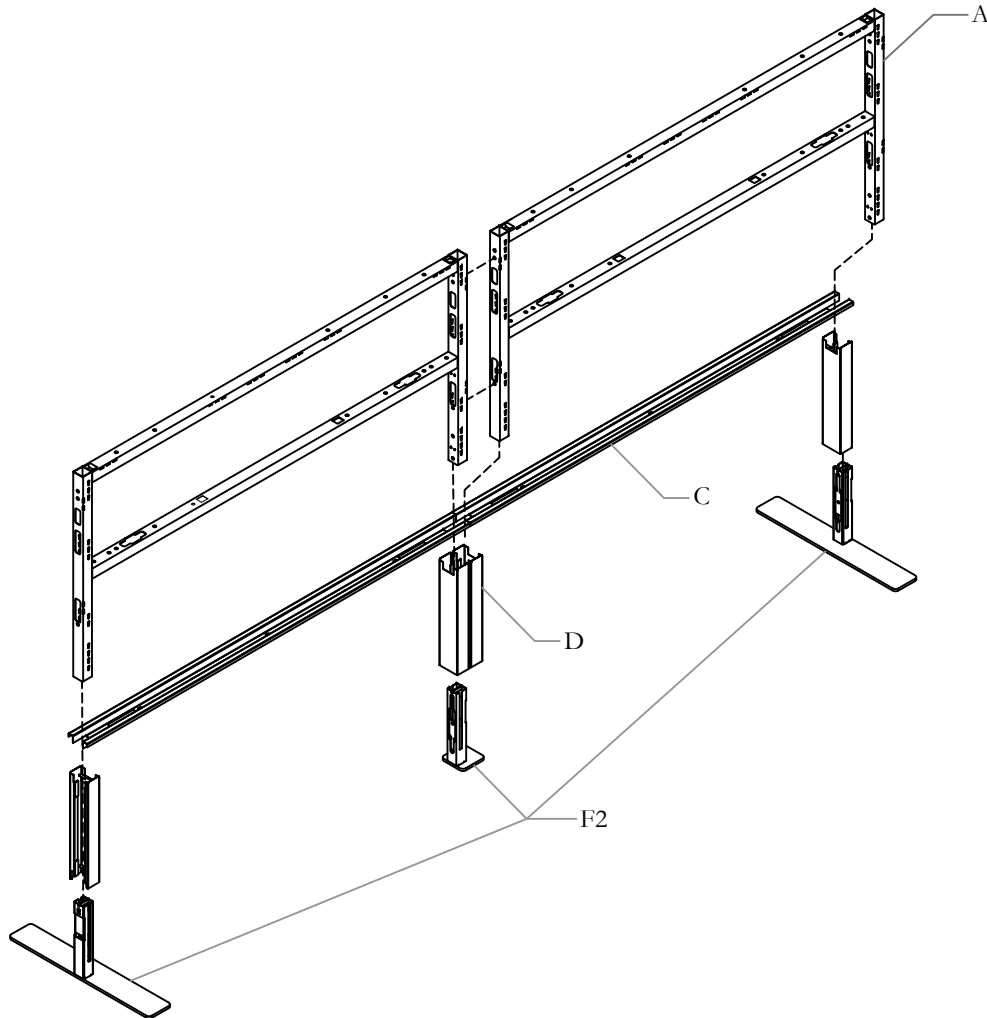

Part and Product Identification

	UYPZ	UNPZ
	A1 - Inset Elevated Power Spine Panel (N02-5541X-X) x varies	A2 - Standard Elevated Power Spine Panel (N02-5512X-X) x varies
B - (X01-1747) x varies		B1 - Hex Flange Locking Bolt 5/16-18x3.5-in Long Plate (E03-0430) x 1
		B2 - Flat Washer (E03-0457) x 2
		B3 - 5/16-18 Lock Nut Zinc Plate (E03-0437) x 1
UZPK		C - Base Trim (A16-12160-X) x varies
		D - Power Beam Leg Weldment (N01-4648) x varies
		E - #12x1" Tapping Screw (E07-0050) x varies
F - Foot Assembly (N02-5365\18, N02-5650\12, N02-5650\03) x varies		F1 - 5/16-18x3/4 Flanged Hex Cap Screw (E01-0997) x varies
		F2 - Power Beam Foot Assembly (N02-5365\18) x 2 (N02-5650\12) x varies (N02-5650\03) x varies

POWER SPINE PANEL ASSEMBLY

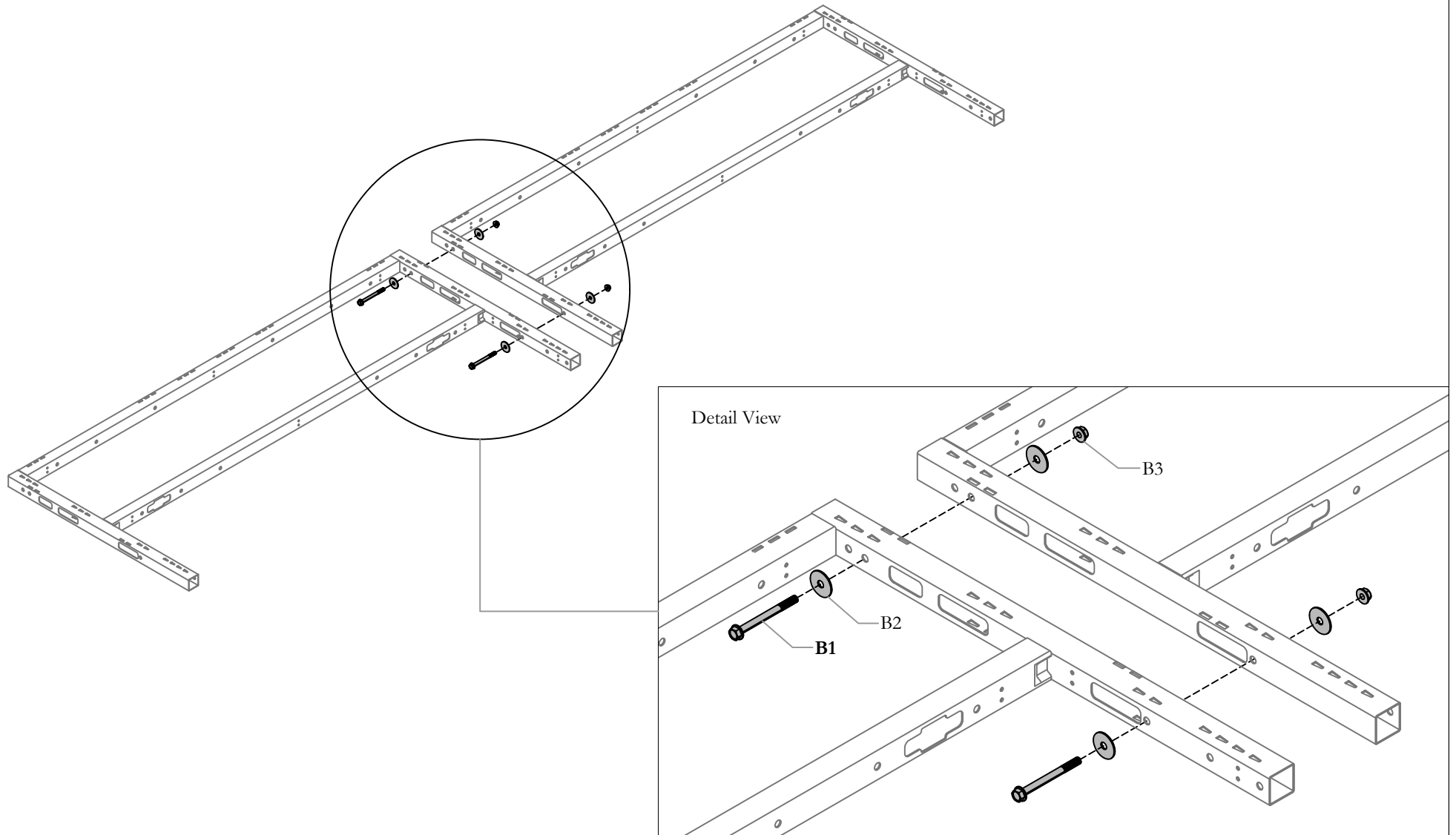

STEP 1: Lay down and align holes on both Elevated Power Spine Panel (A), then secure with Bolts (B1), Washers (B2) and Nuts (B3) as shown.

INSTALL BASE TRIM

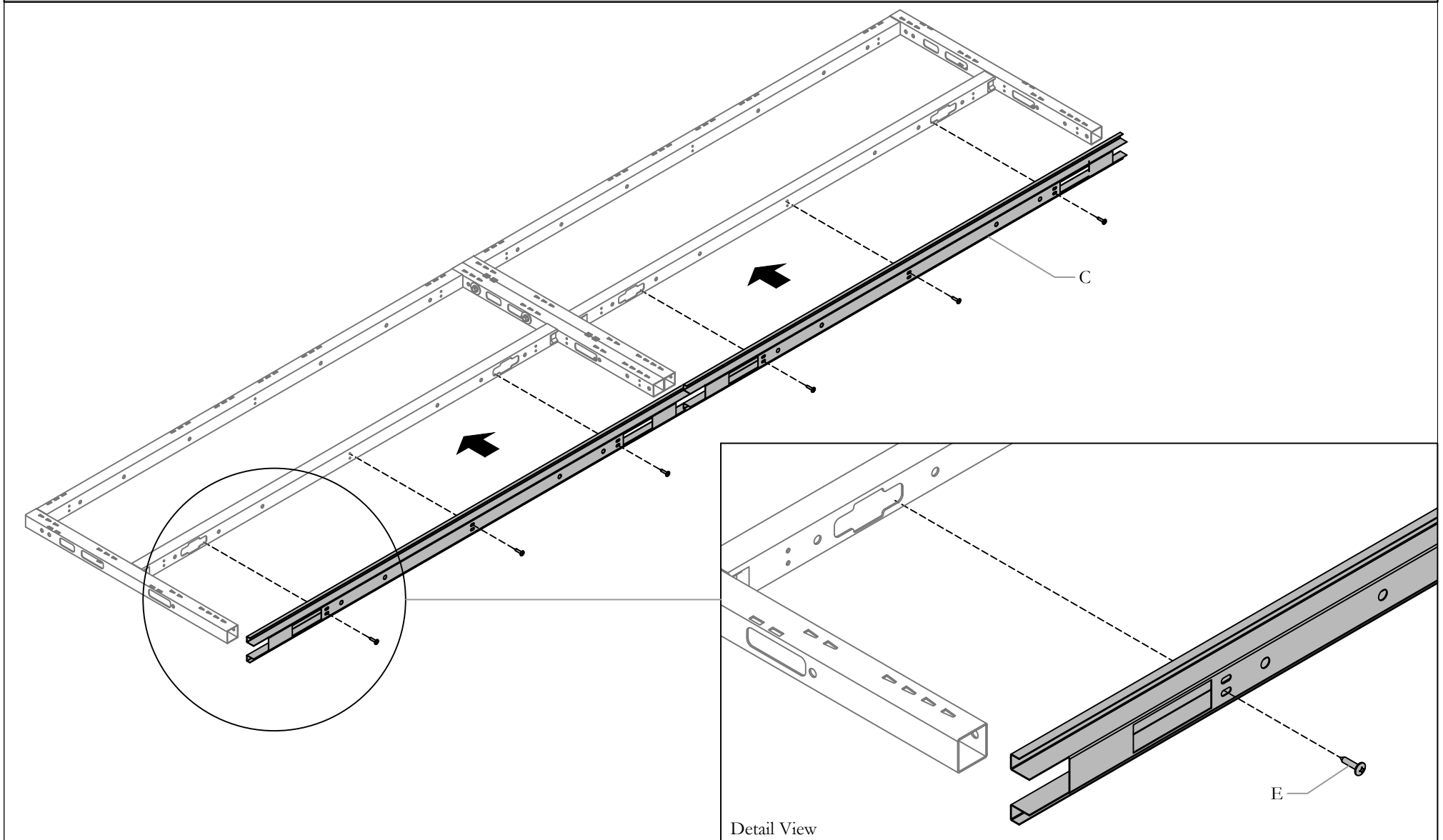

STEP 2: Place the Base Trim (C) underneath the lower horizontal tube. Make sure the Base Trim is centered with respect to the Frames. Secure the Base Trim in place with the Tapping Screws (E) included.

POWER BEAM FEET INSTALLATION (1)

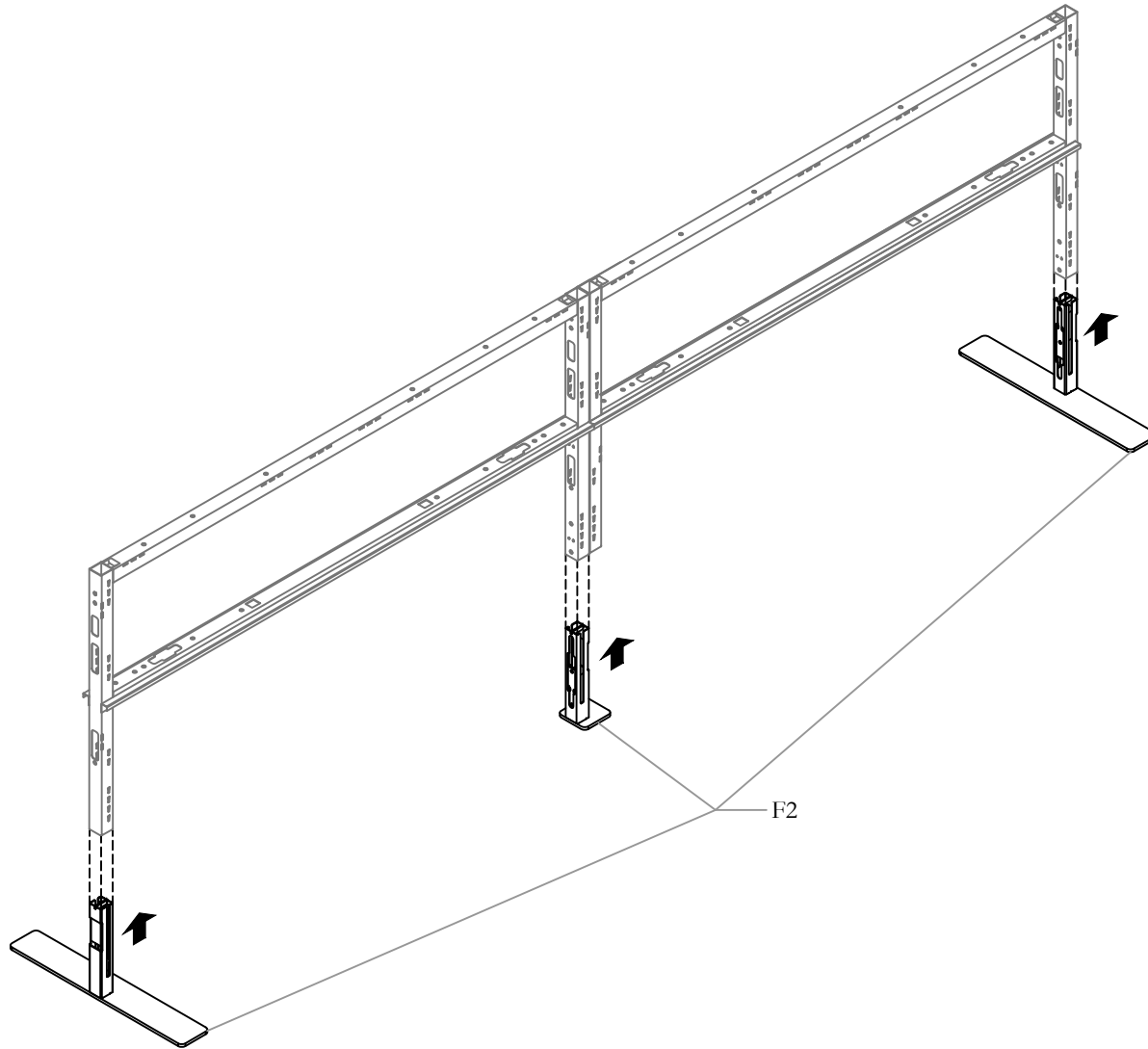

Outer Legs
(Left)

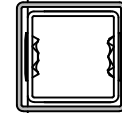

Inner Legs

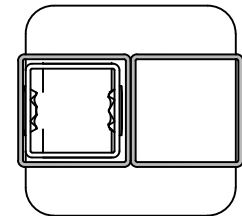

Outer Legs
(Right)

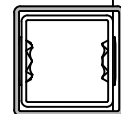

STEP 3: Slide the Power Beam Feet (F2) into the bottom of the Frames.

POWER BEAM FEET INSTALLATION (2)

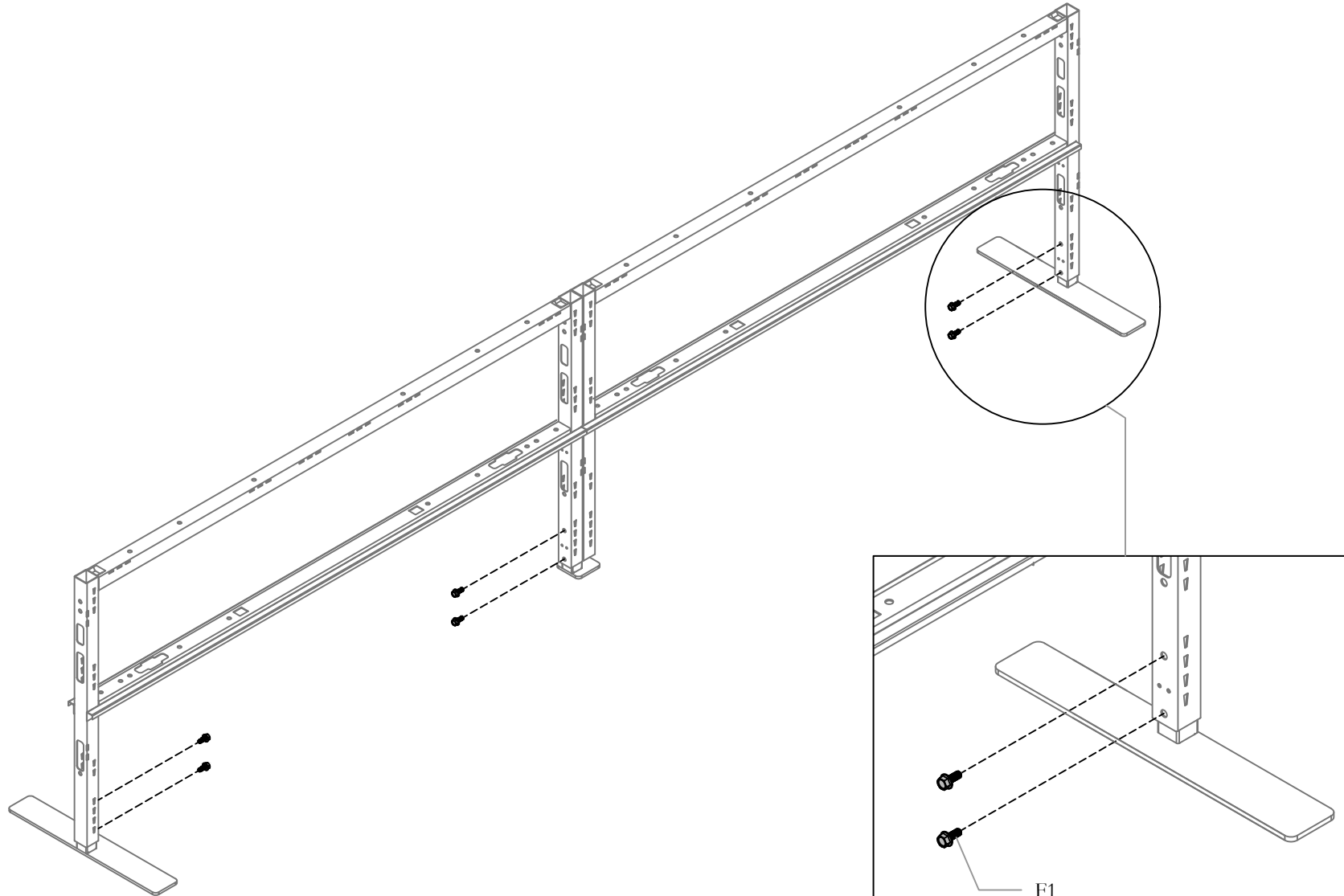

STEP 4: Level the whole Frames assembly, then fasten the Feet to the Frames using the Screws (F1) provided.

POWER SPINE PANEL LEVELING

NOTE: If the Frames' level are uneven, causing a dip, you can correct it by adjusting the leg height.

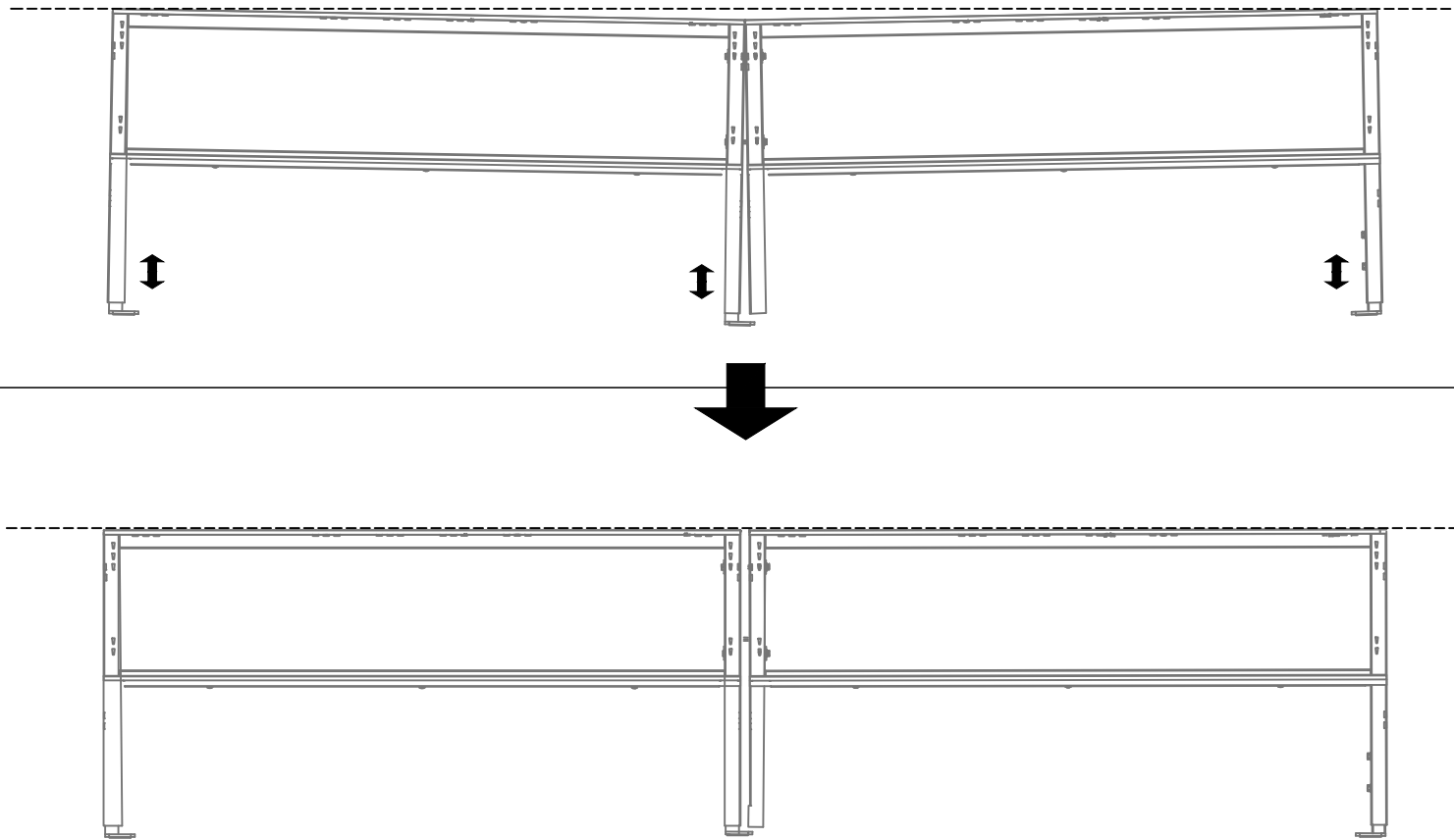

STEP 5: If the Frames' level are uneven, causing a dip, you can correct it by adjusting the leg height until the Frames are level.

ATTACH LEG COVER

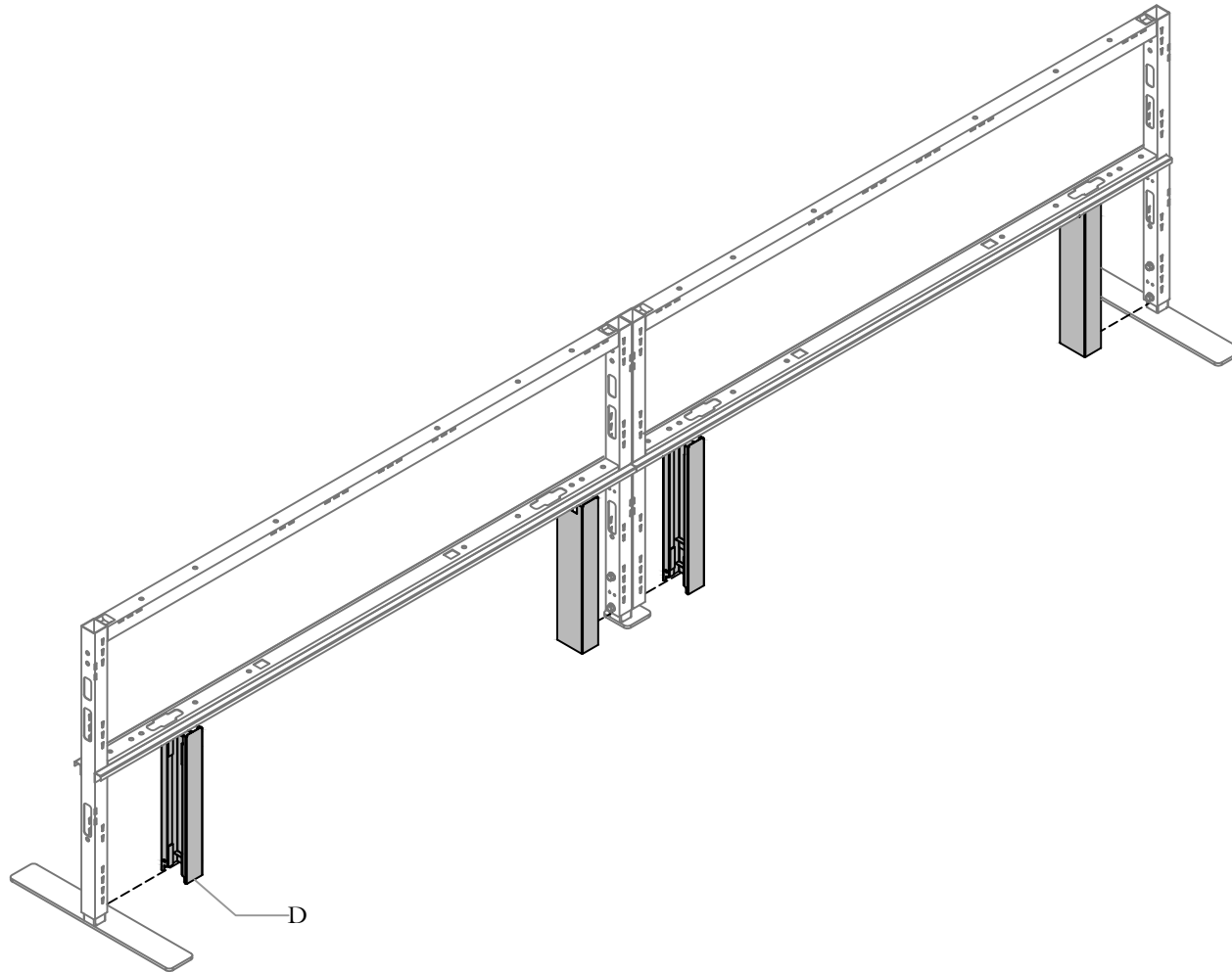

Outer Legs
(Left)

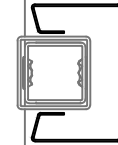

Inner Legs

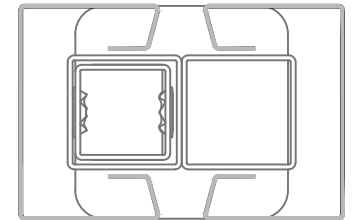

Outer Legs
(Right)

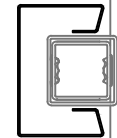

STEP 6: Align the Leg Cover (D) on both Frames, then place them as shown.

Section: **PANEL WALLS - POWER SPINE**





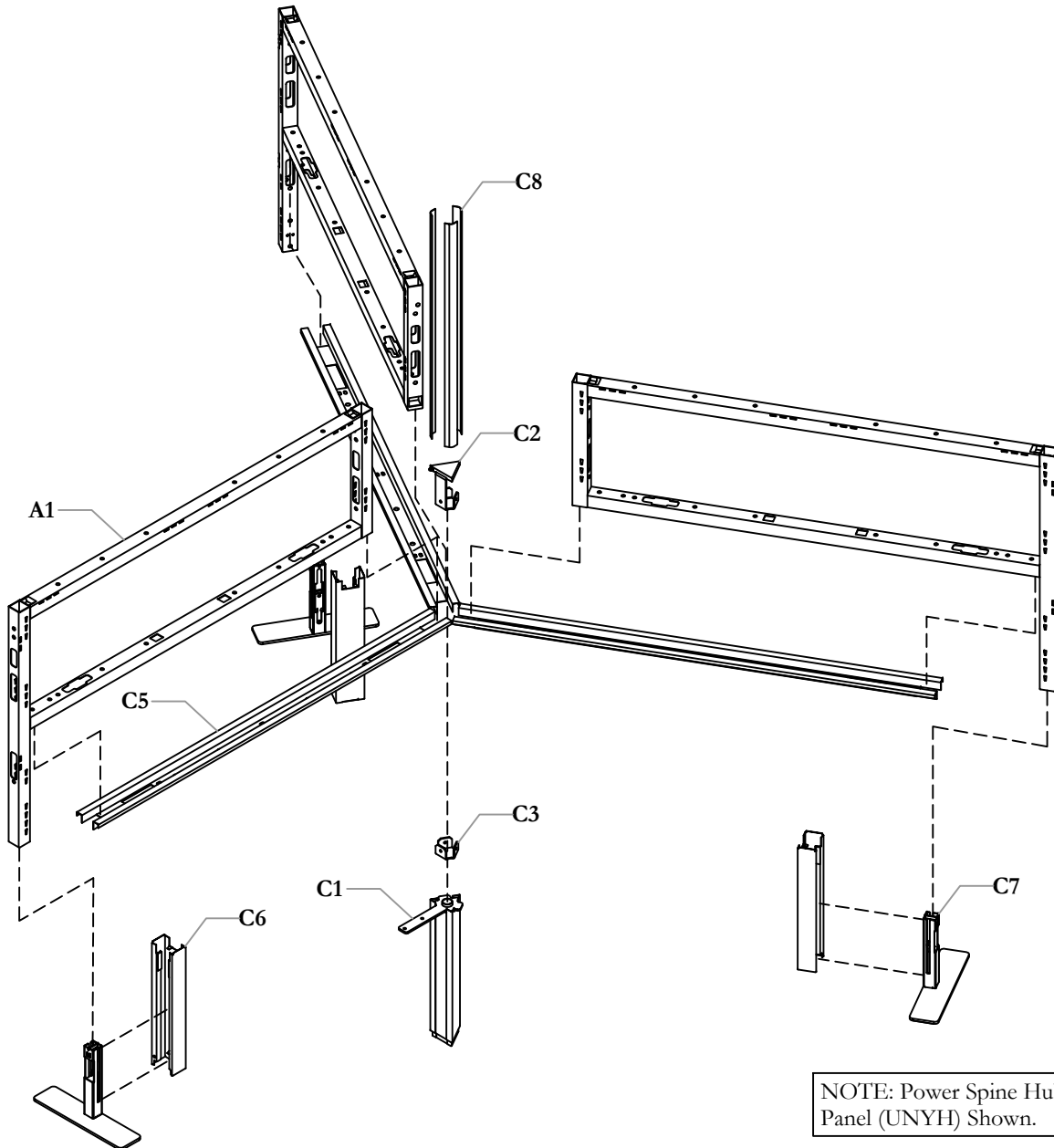

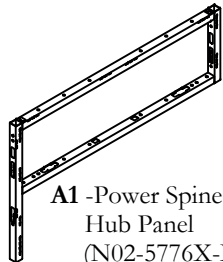
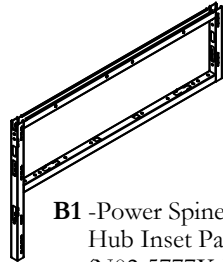
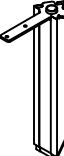
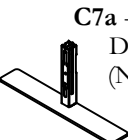

Description: **POWER SPINE 120 HUB PANEL**

Power Spine 120 Hub Panel (UNYH), Power Spine 120 Hub Inset Panel (UZYH), Power Spine 120 Hub Support Kit (UZYK)

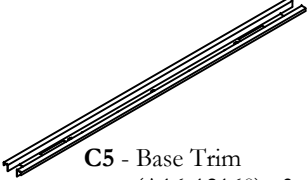

NOTE: Power Spine Hub Panel (UNYH) Shown.

Part and Product Identification

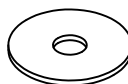
A - UNYH	B - UZYH
 <p>A1 - Power Spine 120 Hub Panel (N02-5776X-X) x3</p>	 <p>B1 - Power Spine 120 Hub Inset Panel (N02-5777X-X) x3</p>
<p>C - Power Spine 120 Support Kit (UZYK)</p>	<p>C7 - Power Spine Medium Foot Assembly (N02-5365) x3</p>
 <p>C1 - 120 Power Spine Post Assembly (N01-5742) x1</p>	 <p>C7a - Foot Weldment, District (N02-5364) x1</p>
 <p>C2 - Top Cap 120 Deg Assembly (N01-5953) x1</p>	 <p>C7b - Screw 5/16-18x³/₄ Flanged Hex Head Cap Screw, Steel, Zinc (E01-0997) x2</p>
 <p>C3 - 3 Way 120 Corner Bracket (A15-7337) x1</p>	 <p>C8 - Corner Light Block Cut Length (B11-0944) x3</p>
 <p>C4 - Hex Flange Locking Bolt 5/16-18x2\" (E03-0428) x6</p>	 <p>C9 - 12x1\" Type AB, Truss Head, Tapping Screw, Black (E07-0050) x9</p>
 <p>C5 - Base Trim (A16-12160) x3</p>	 <p>C10 - Screw 5/16-18x³/₄ Flanged Hex Head Cap Screw, Steel, Zinc (E01-0997) x2</p>
 <p>C6 - Power Spine Leg Cover Assembly (N01-4648) x3</p>	 <p>C11 - Flat Washer 11/32 ID 1-1/4 OD 1/16 TH (E03-0457) x2</p>

INSTALL BASE TRIM

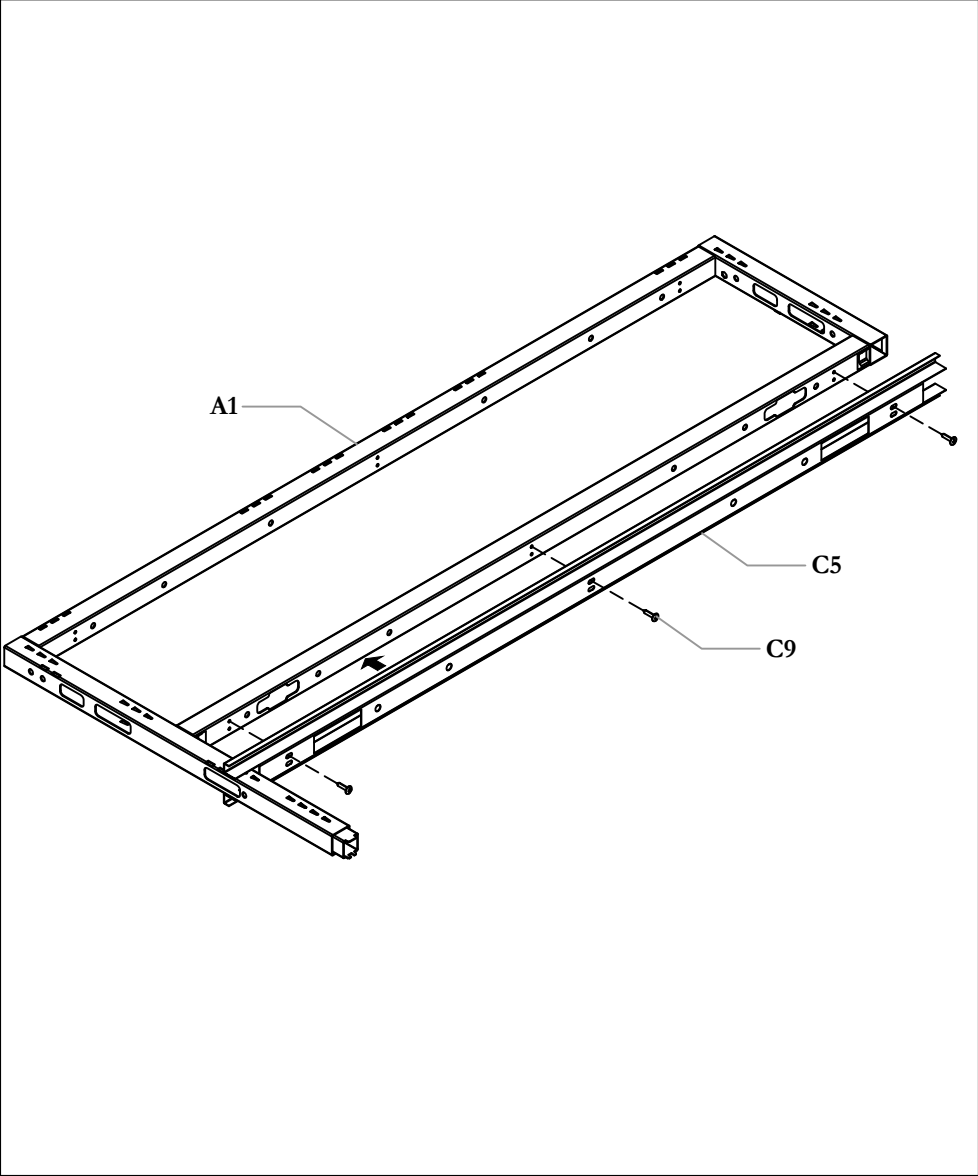

STEP 1a: Install Bottom Cover.

INSTALL OUTER LEG - 1

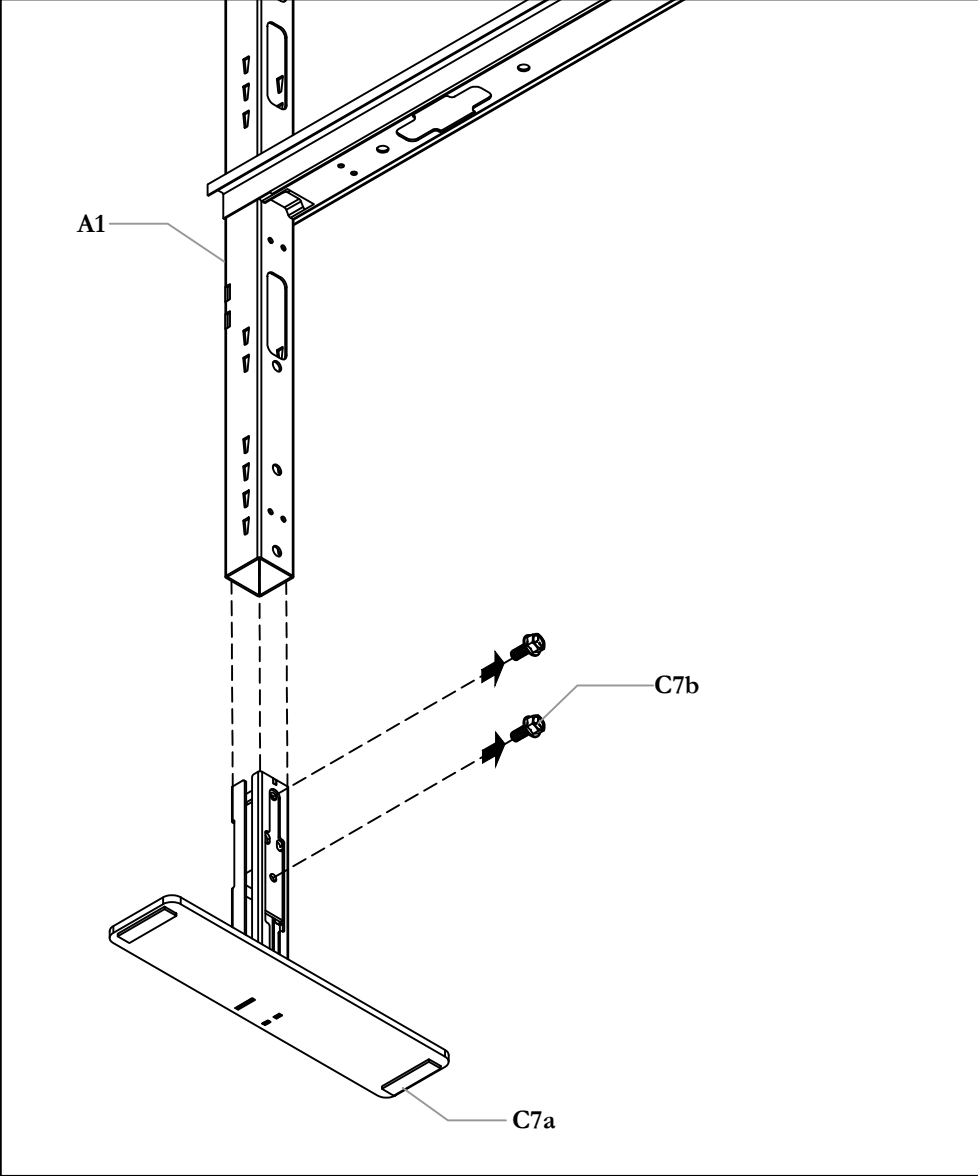

STEP 1b: Install Leg Piece. Remove Screws in leg assembly before installing leg.

Section: **PANEL WALLS - POWER SPINE**

Description: **POWER SPINE 120 HUB PANEL**

INSTALL OUTER LEG - 2

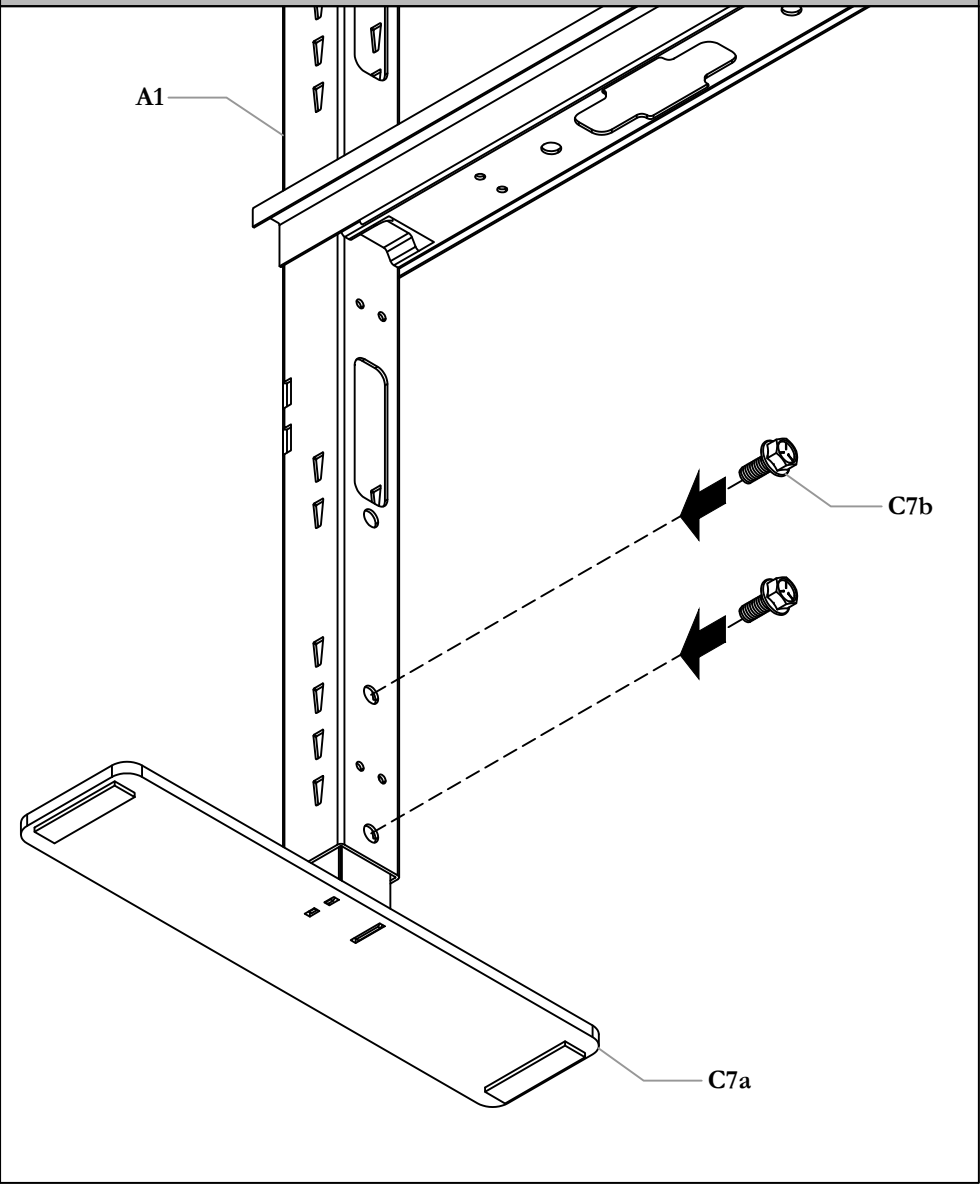

STEP 1c: Adjust the Leg Piece to the desired height and tighten hex screws.

INSTALL CENTER LEG - 1

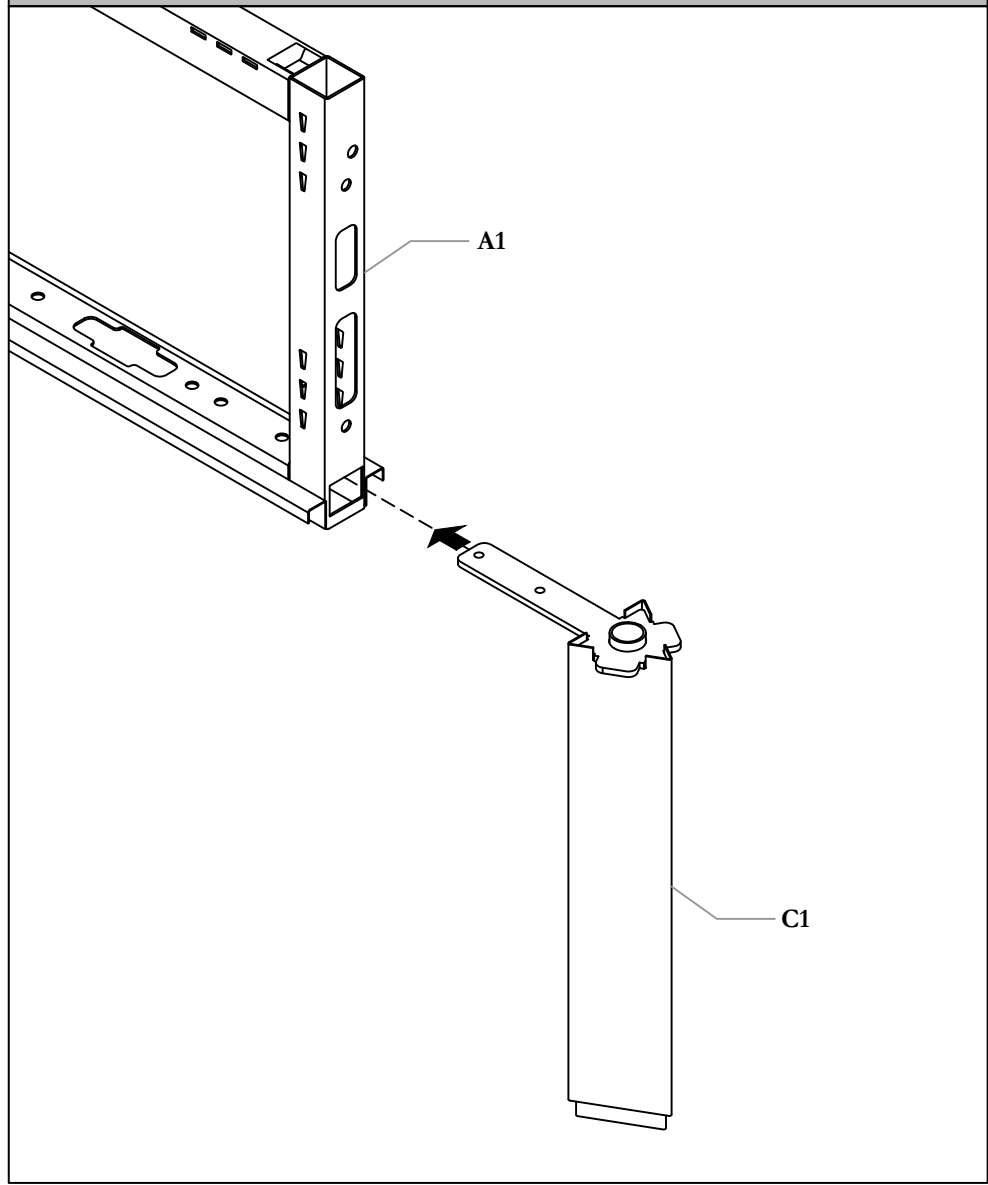

STEP 2a: Line up the long side of the Power Spine Post Assembly and slide it in. Line up the holes of the Power Spine Post Assembly to the holes on the Power Spine 120 Hub Panel.

Section: **PANEL WALLS - POWER SPINE**

Description: **POWER SPINE 120 HUB PANEL**

INSTALL CENTER LEG - 2

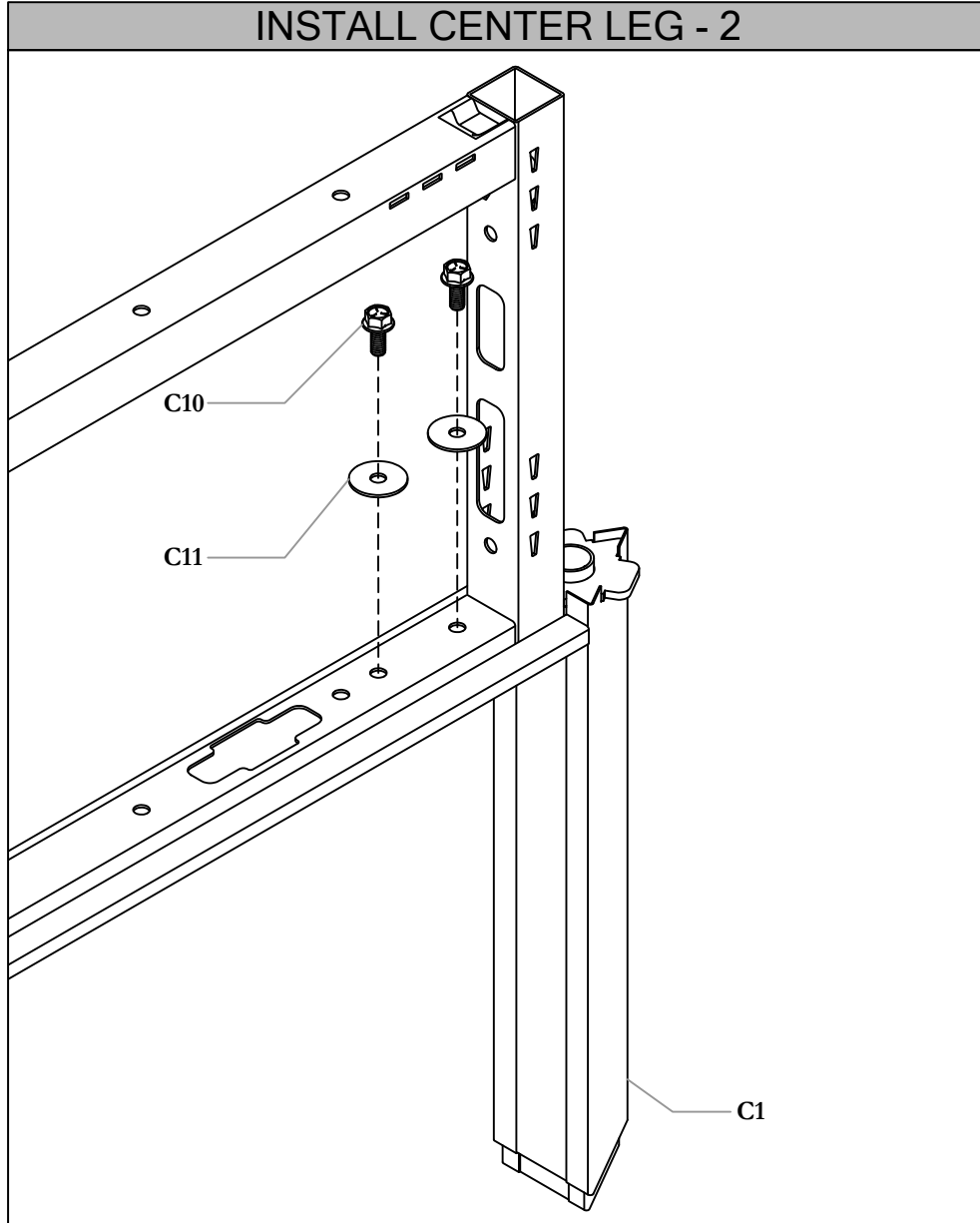

STEP 2b: Install the Washers and Screws as shown above.

LEVEL CENTER LEG

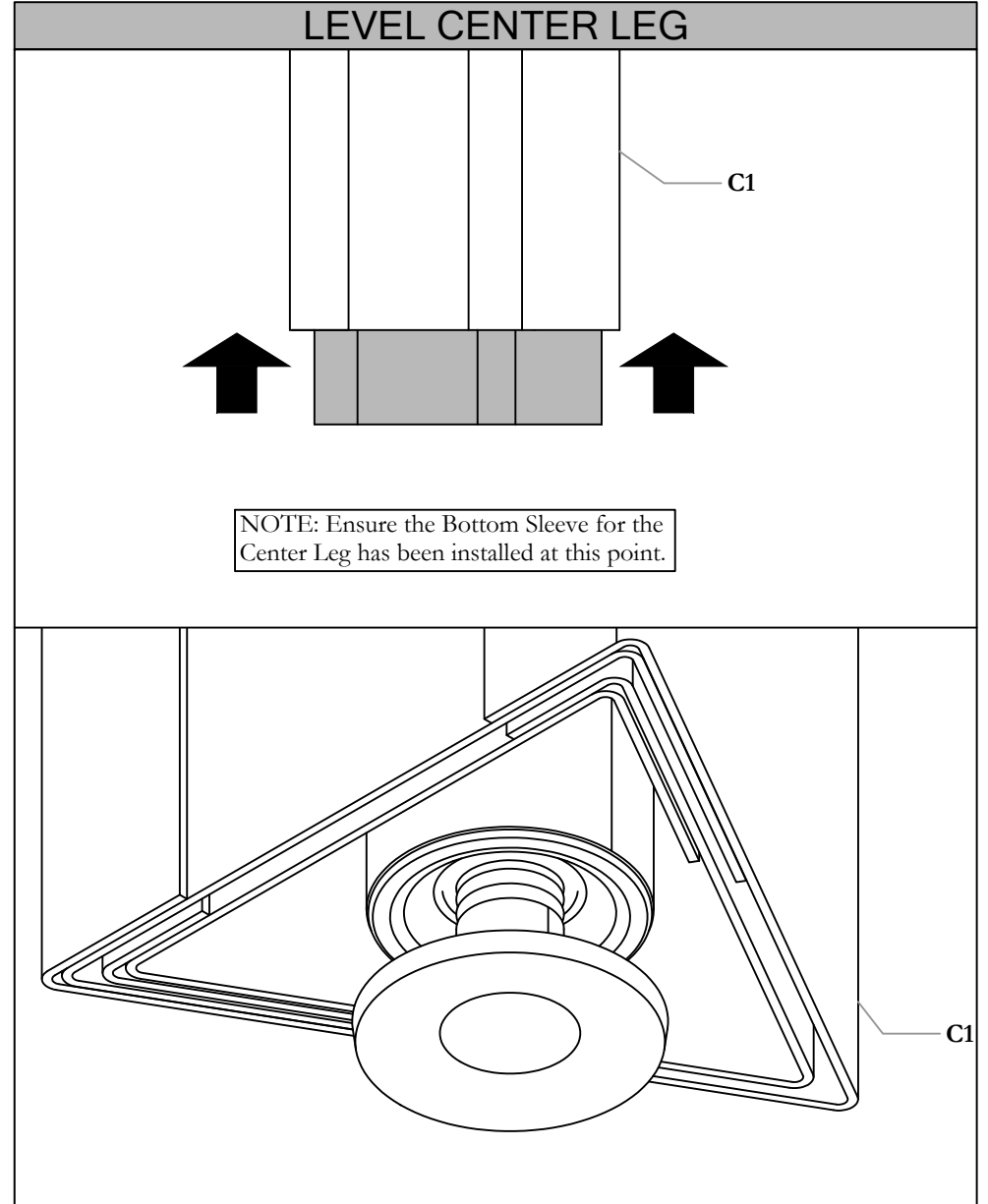

STEP 2c: Slide up the Bottom Sleeve to reveal the Panel Leveler. The Leveler is a Right-Hand Thread, right spin to lower level and left spin to raise level.

NOTE: Ensure the Bottom Sleeve for the Center Leg has been installed at this point.

INSTALL CENTER TRIM AND BRACKET

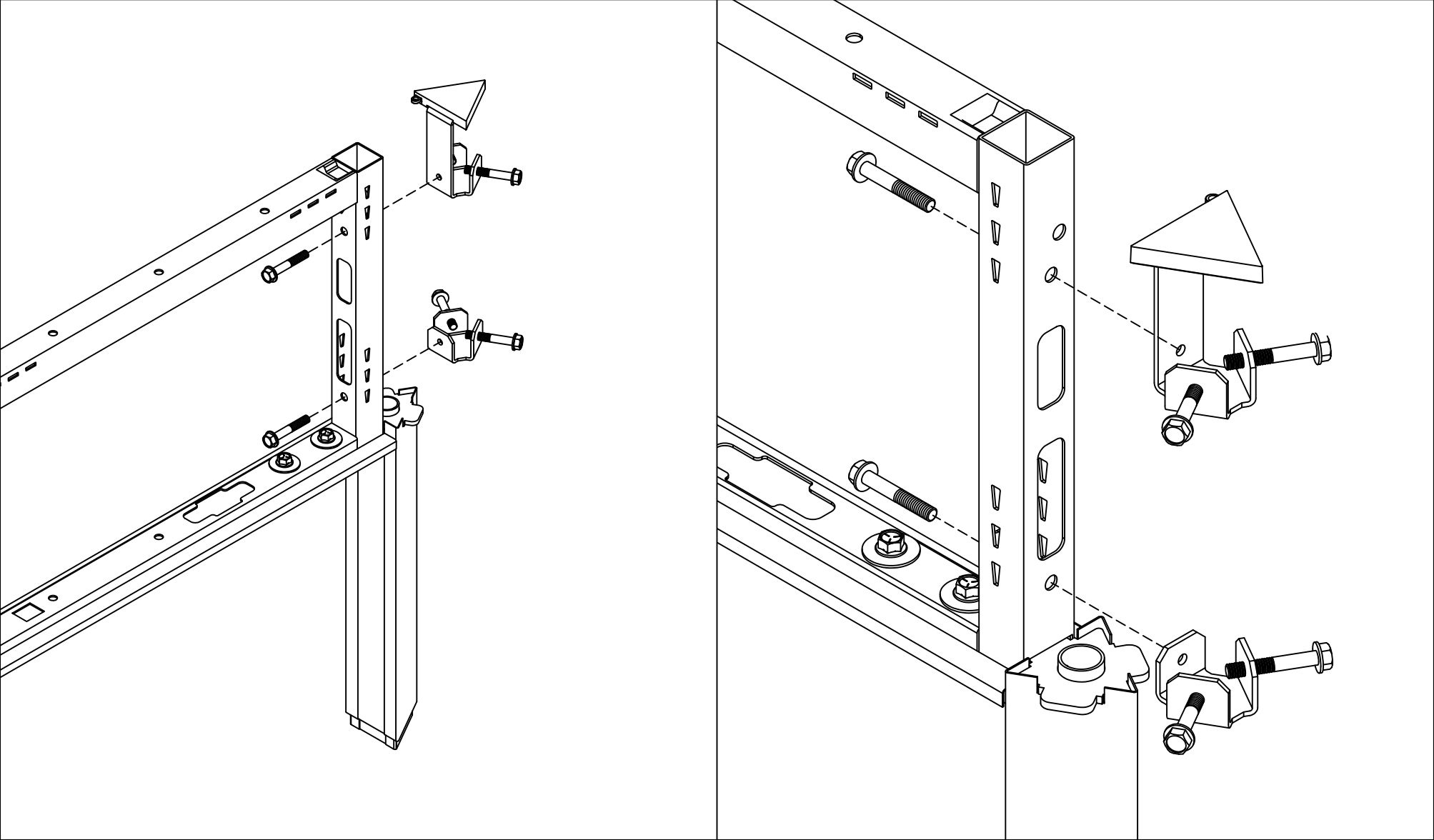

STEP 3: Install Top Cap 120 Deg Assembly & 3 Way 120 Corner Bracket.

Section: **PANEL WALLS - POWER SPINE**

Description: **POWER SPINE 120 HUB PANEL**

REPEAT PREVIOUS STEPS FOR OTHER PANELS

NOTE: Level the complete assembly if necessary.

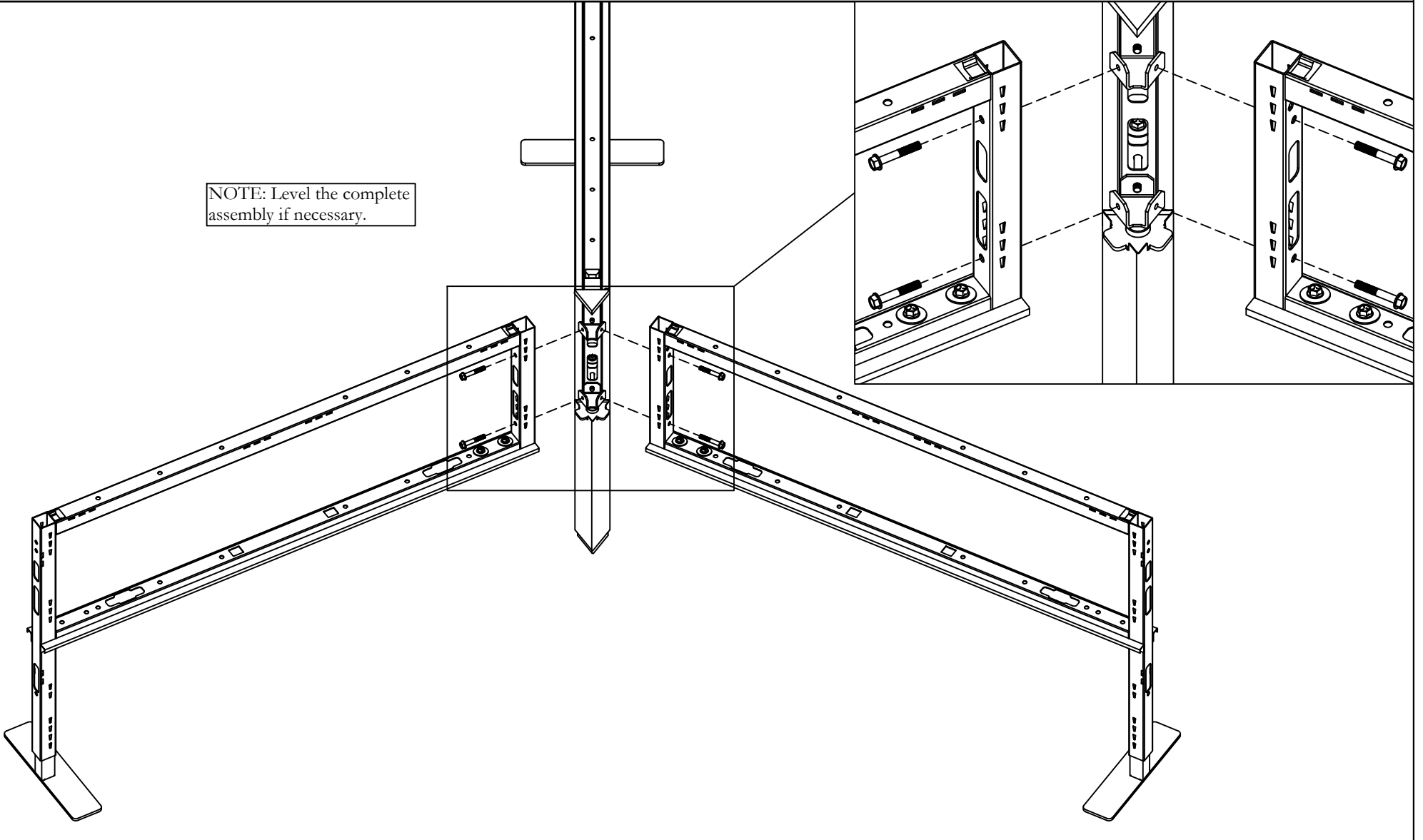

STEP 4: Repeat Steps 1 and 3 for the other 2 Power Spine 120 Hub Panels and install onto the Power Spine Foot assembly and 3 Way Corner Bracket.

NOTE: Level the complete assembly if necessary.

Section: **PANEL WALLS - POWER SPINE**

Description: **POWER SPINE 120 HUB PANEL**

INSTALL POWER SPINE LEG COVER

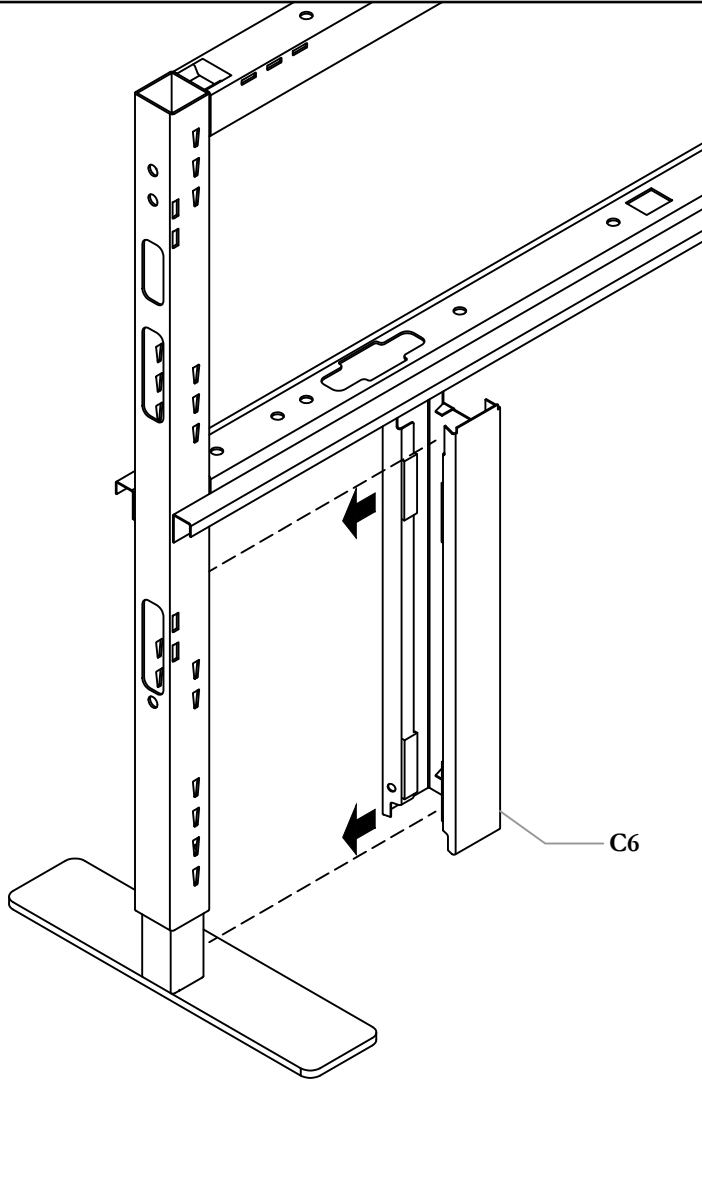

STEP 5: Install Power Spine Leg Cover Assembly on each of the 3 Legs.

INSTALL CORNER LIGHT BLOCK

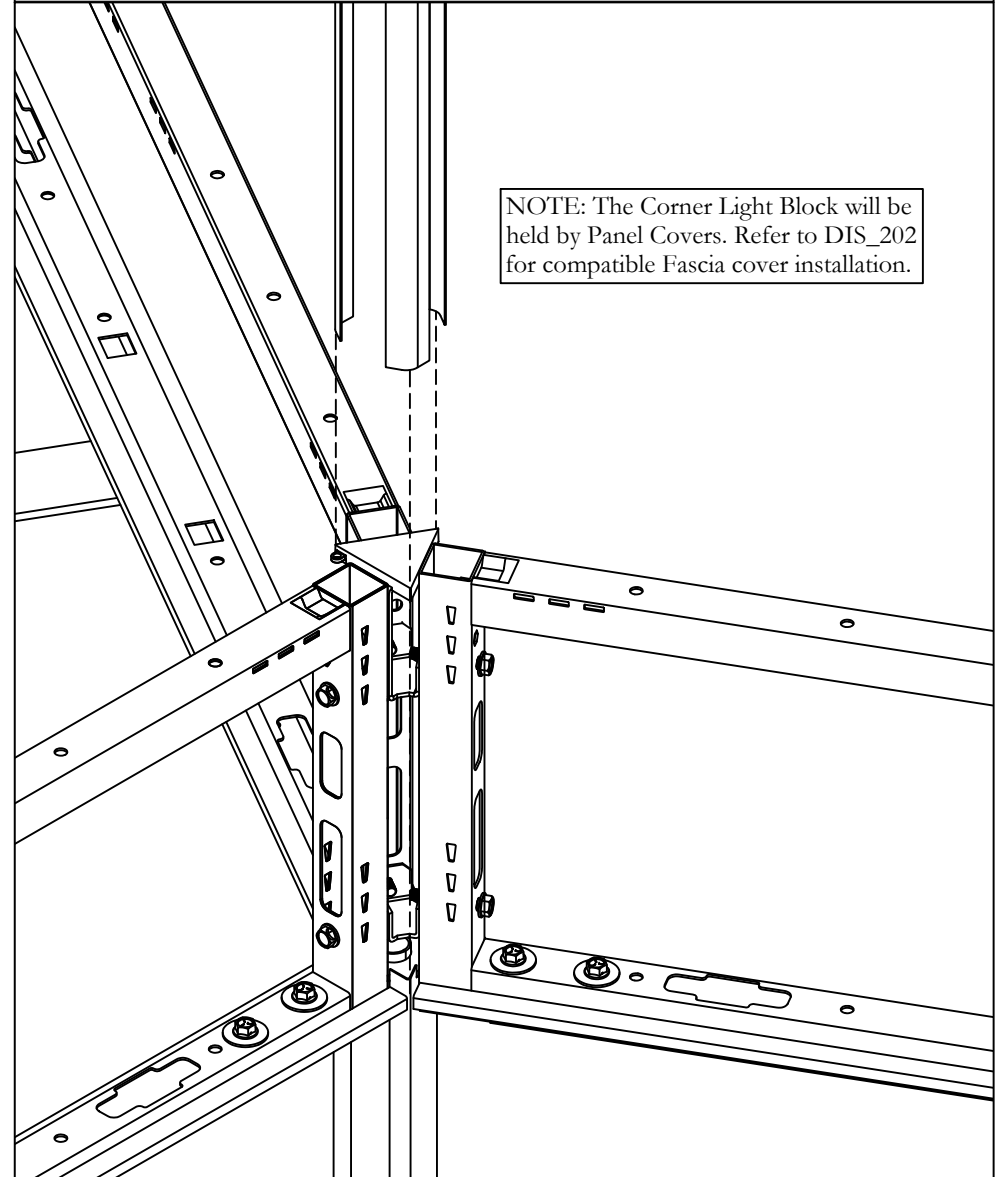

STEP 6: Install Corner Light Block.

NOTE: The Corner Light Block will be held by Panel Covers. Refer to DIS_202 for compatible Fascia cover installation.

Section: **PANEL WALLS - POWER SPINE**
Description: **ZIG ZAG POWER SPINE PANEL**

Zig Zag Power Spine Panel (UNZZ), Zig Zag Power Spine Inset Panel (UYZZ), Power Spine Zig Zag Support Kit (UZZK)

NOTE: UNZZ Shown, with product length of 288".

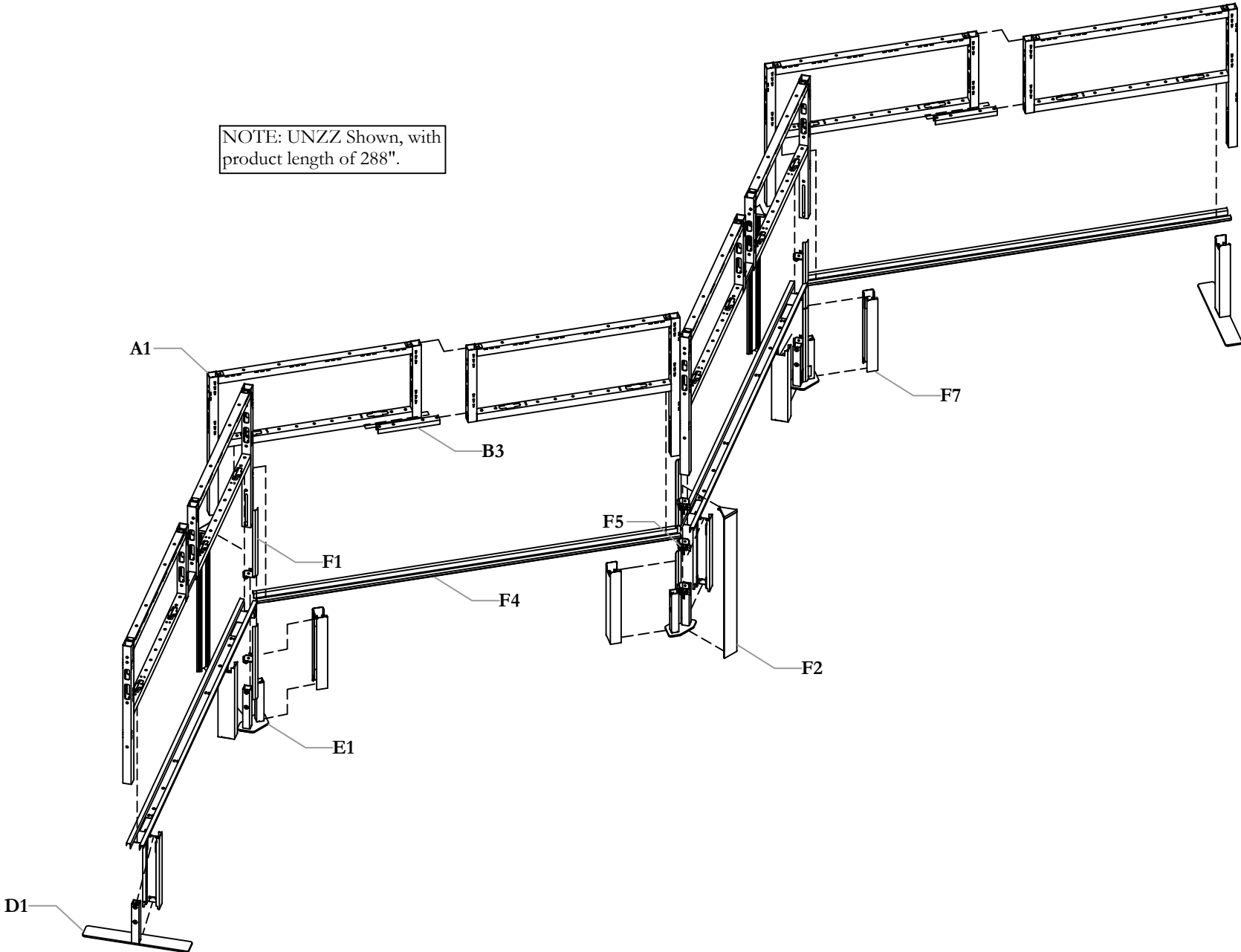

Part and Product Identification

	UNZZ	UYZZ	UZZK	
	<p>A1 - Zig Zag Power Spine Panel (N02-5512X-X) x Qty Varies</p>	<p>A2 - Zig Zag Power Spine Inlay Panel (N02-5541X-X) x Qty Varies</p>	<p>D - Foot Assembly (N02-5365\18) x2</p> <p>D1 - Power Spine Foot (N02-5364\18) x 1</p> <p>D2 - Screw 5/16-18x3/4 Flanged Hex Head Cap Screw, Steel, Zinc (E01-0997) x 2 *Shipped loose*</p>	<p>F3 - 12x1" Type AB, Truss Head, Tapping Screw, Black (E07-0050) x Qty Varies</p>
			<p>E - 120° Foot Assembly (N02-5715)</p> <p>E1 - Power Spine Double Foot (N02-5714) x Qty Varies</p> <p>E2 - Screw 5/16-18x3/4 Flanged Hex Head Cap Screw, Steel, Zinc (E01-0997) x Qty Varies *Shipped loose*</p>	<p>F4 - Base Trim (A16-12160-X) x Qty Varies</p> <p>F5 - 2-Way 120 Bracket Assembly (N09-1707) x Qty Varies</p>
B - (X01-3755)	<p>B1 - Screw 5/16-18x3/4 Flanged Hex Head Cap Screw, Steel, Zinc (E01-0997) x Qty Varies</p> <p>B2 - Flat Washer 11/32 ID 1-1/4 OD 1/16 TH (E03-0457) x Qty Varies</p> <p>B3 - Bottom Splicer (N01-4667) x Qty Varies</p>			
C - (X01-1747)	<p>C1 - Hex Flange Locking Bolt 5/16-18x3.5-in Long Plate (E03-0430) x Qty varies</p> <p>C2 - Flat Washer (E03-0457) x Qty varies</p> <p>C3 - 5/16-18 Lock Nut Zinc Plate (E03-0437) x Qty varies</p> <p>C4 - 1/4-20x2 Pan Phillips Machine Screw 18-8 Stainless Steel (E01-1227) x Qty Varies</p>		<p>F1 - Corner Light Block (B11-0944) x Qty Varies</p> <p>F2 - 2-Way 120 Power Spine Corner Trim (N01-5952-X) x Qty Varies</p>	<p>F6 - Hex Flange Locking Bolt 5/16-18x2" (E03-0428) x Qty Varies</p> <p>F7 - Power Spine Leg Cover Assembly (N01-4648) x Qty Varies</p>

SECURE POWER SPINE PANELS - 1

NOTE: Product Codes with length of 14A, 180, 192, 240, 24A, 300 do not perform this step.

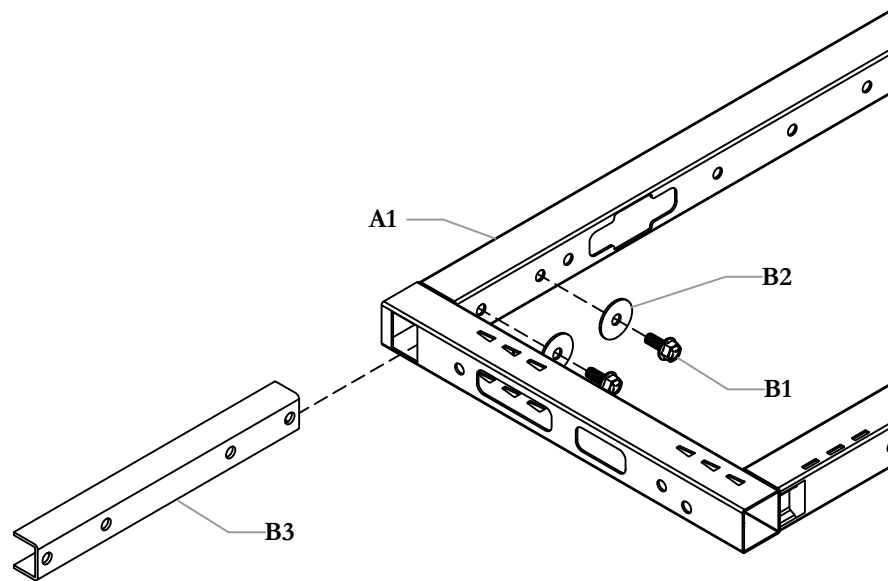

STEP 1a: Slide in Bottom Splicer into a Power Spine Panel (A1) and align holes as shown.

NOTE: Product Codes with length of 14A, 180, 192, 240, 24A, 300 do not perform this step.

SECURE POWER SPINE PANELS - 2

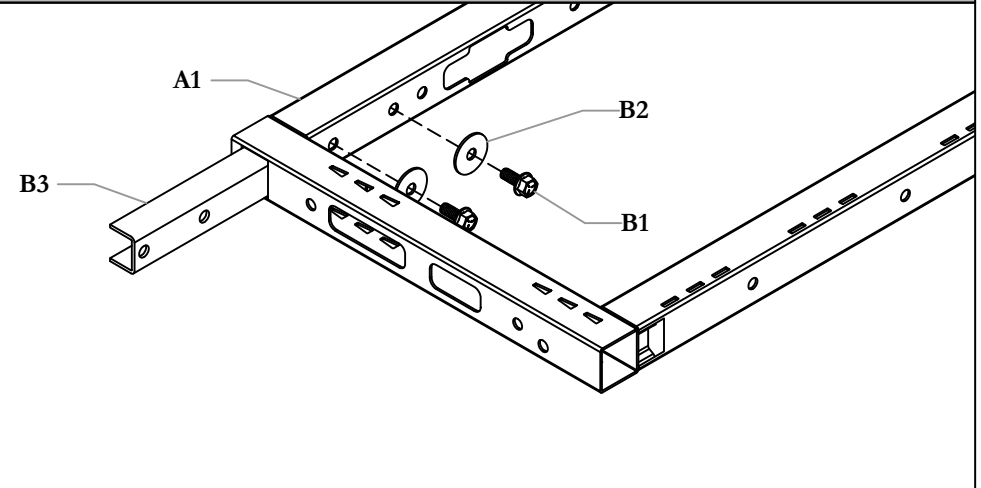

STEP 1b: Secure the Bottom Splicer (B3) to the Power Spine Panel (A1).

SECURE POWER SPINE PANELS - 3

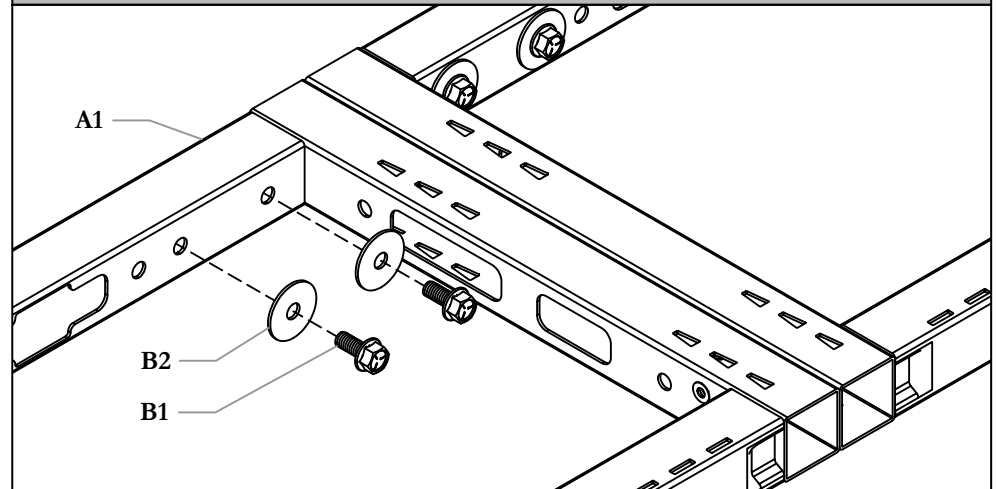

STEP 1c: Bring another Power Spine Panel (A1) and align the bottom Splicer (B3) holes to the Power Spine Panel holes.

SECURE POWER SPINE PANELS - 4

NOTE: Ensure that the two Power Spine Panels are flat on the ground when fully secured.

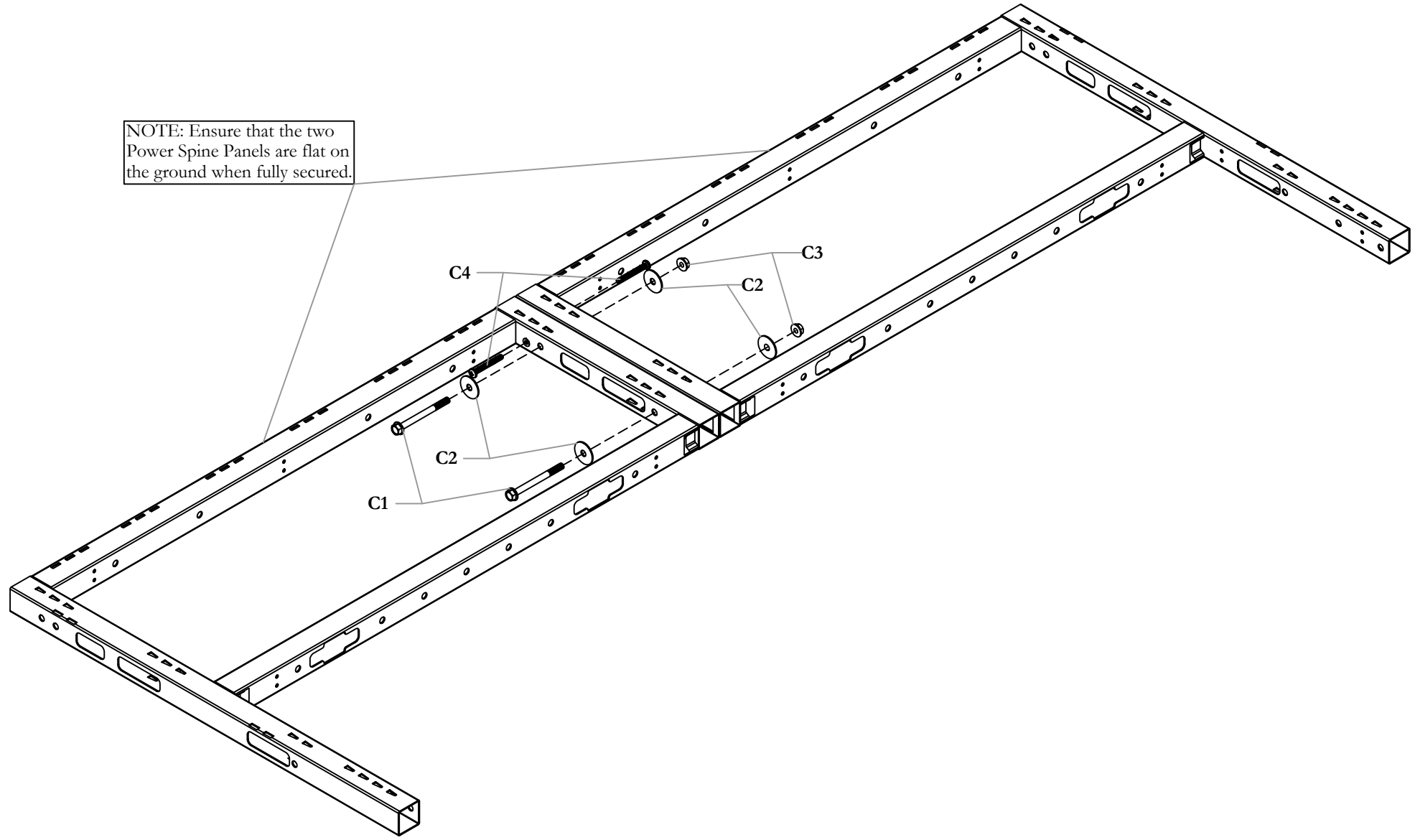

STEP 1d: Install remaining screws and bolts snug to secure two Power Spine Panels together.

NOTE: Ensure that the two Power Spine Panels are flat on the ground when fully secured.

INSTALL BASE TRIM

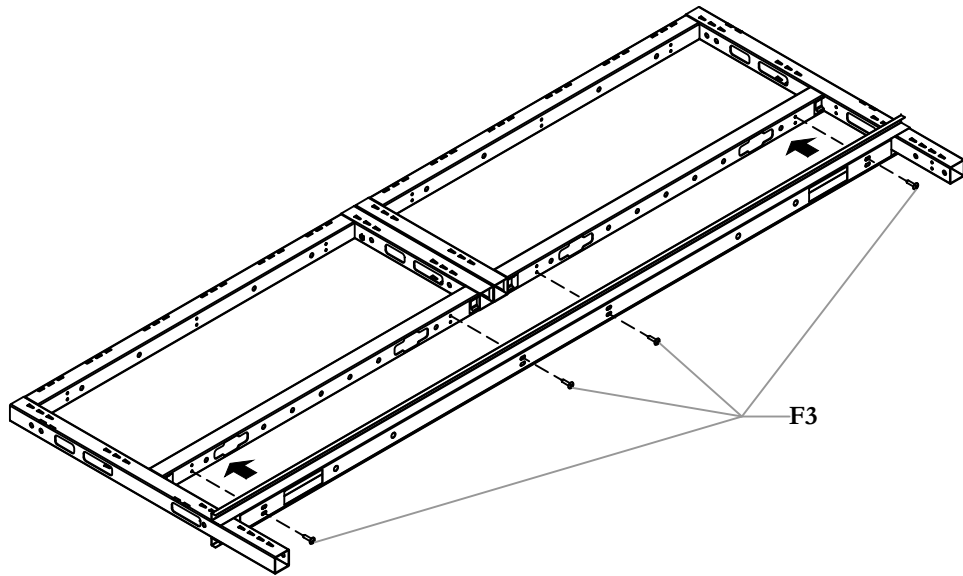

STEP 2: Install Base Trim using screw (F3).

INSTALL END LEG - 1

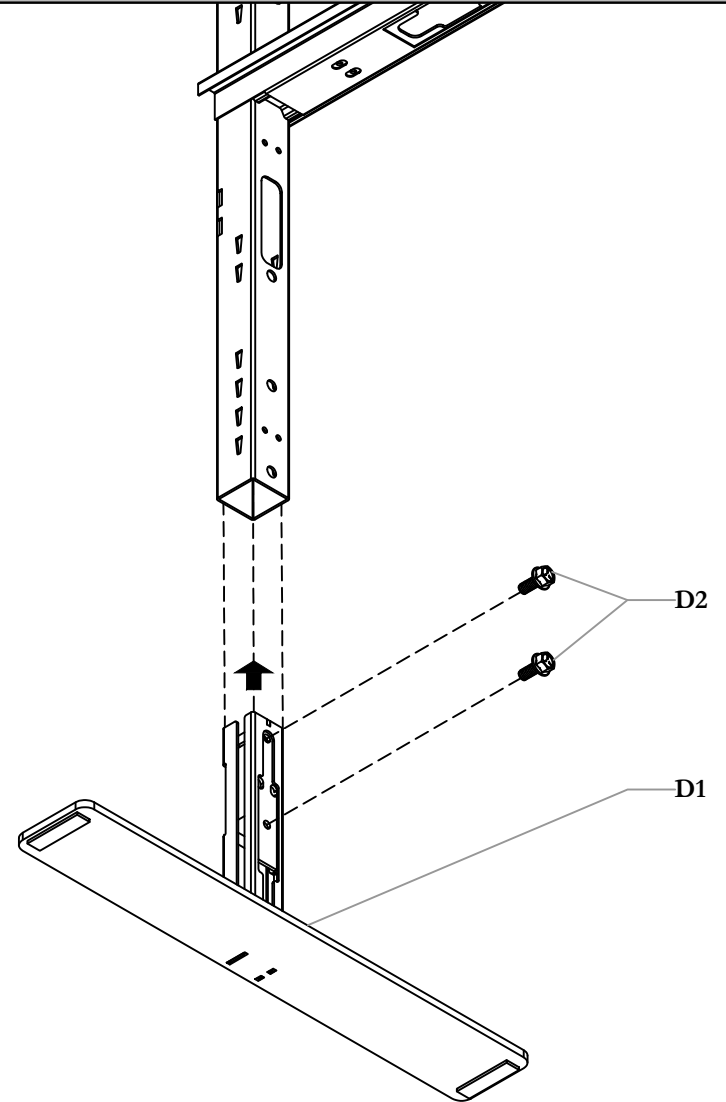

STEP 3a: Install Power Spine Foot using Hex screw (D2).

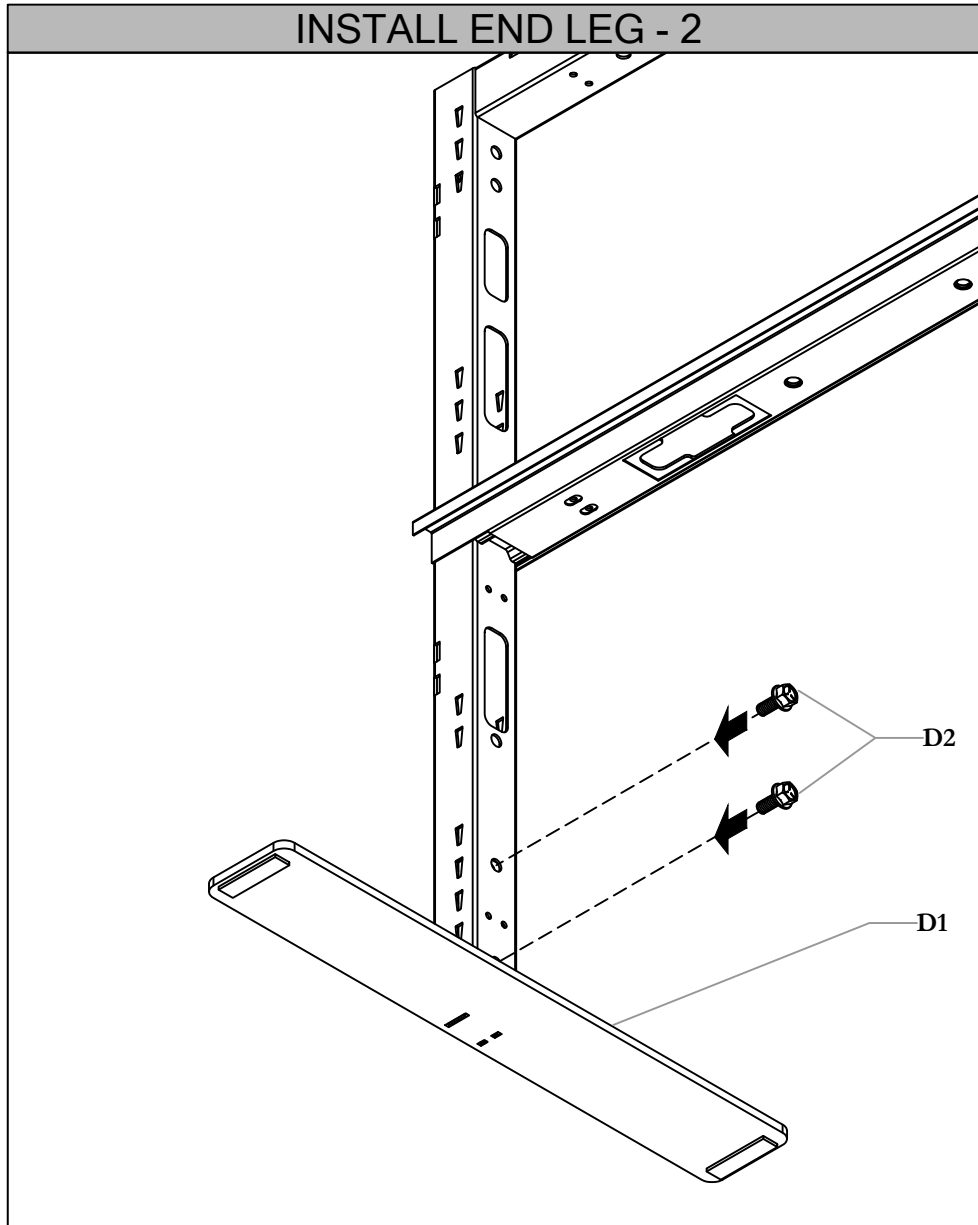

STEP 3b: Adjust the Power Spine Foot (D1) to the desired height and tighten hex screws(D2).

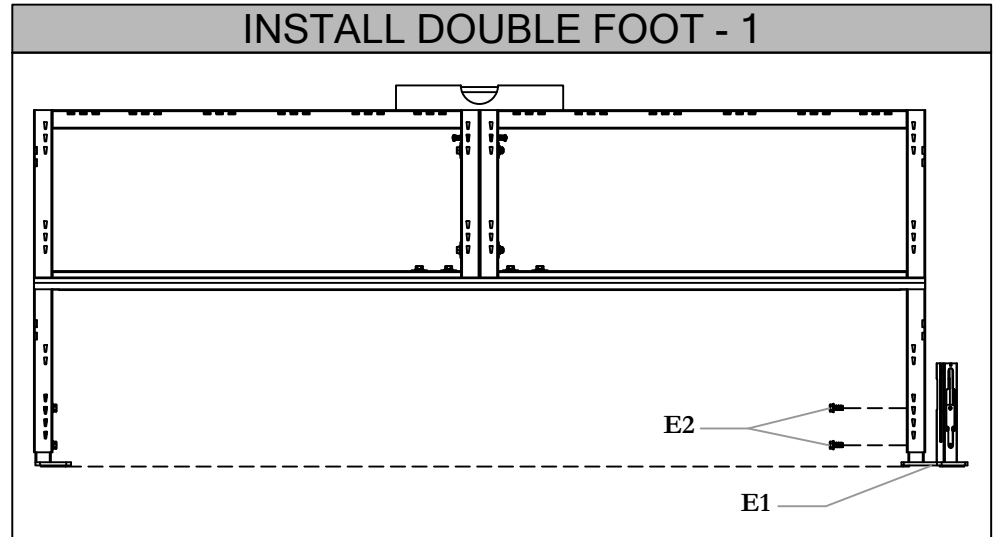

STEP 4a: Install Power Spine Double Foot (E1). Make sure that the Power Spine Panel Assembly is Level before tightening Hex Screws (E2).

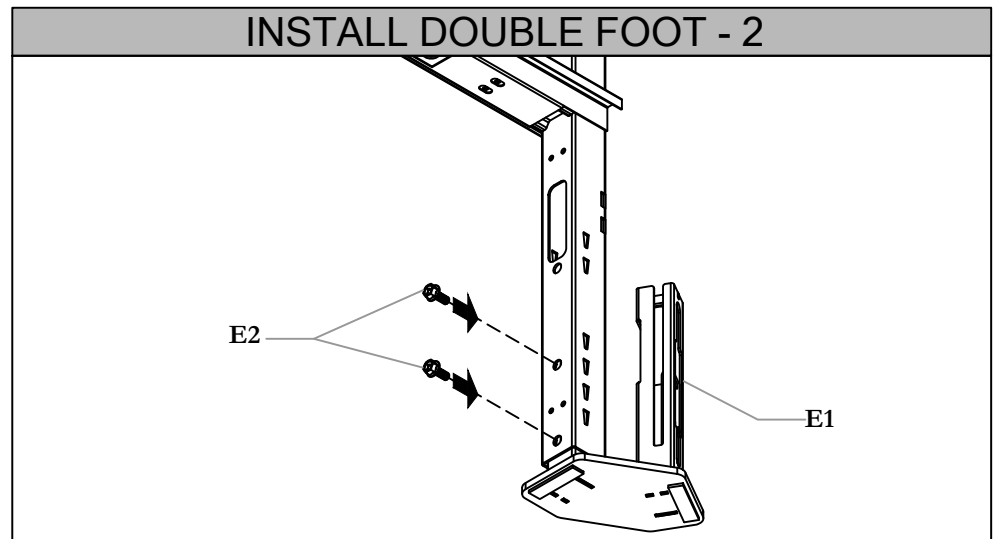

STEP 4b: Once the Power Spine Double Foot (E1) is level, tighten Hex Screws (E2).

INSTALL BRACKETS

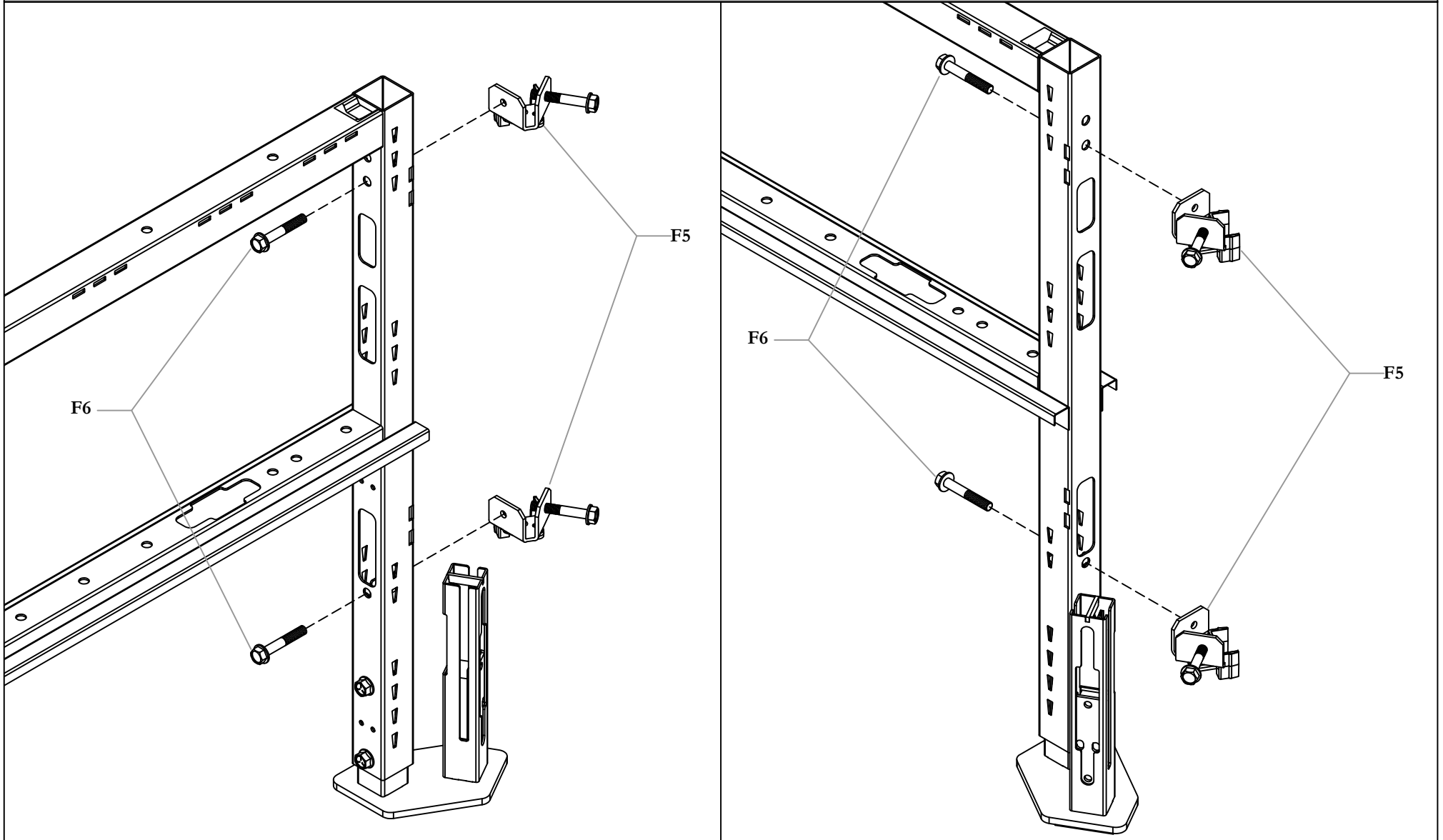

STEP 5: Secure Brackets(F5) onto the frame using Hex Flange (F6).

NOTE: UYZZ29 & UNZZ29 requires 2 Brackets, while UYZZ42 requires 3 Brackets

Section: **PANEL WALLS - POWER SPINE**

Description: **ZIG ZAG POWER SPINE PANEL**

REPEAT STEPS 1,2,4 & 5

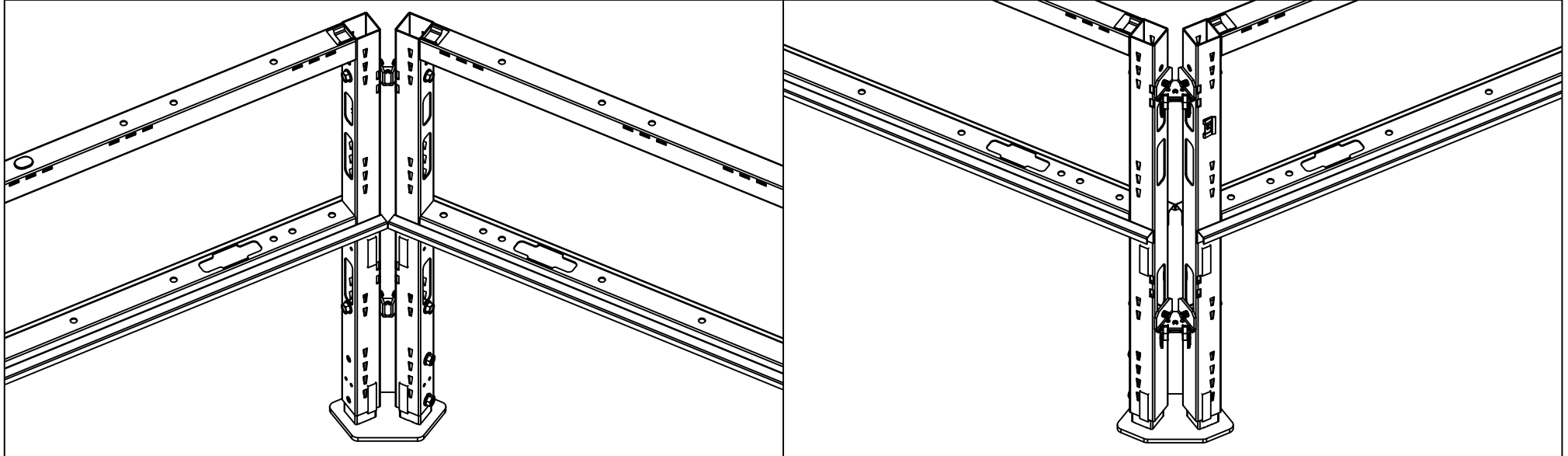

NOTE: Make sure to level each Power Spine Panel before securing to Brackets and Double Foot.

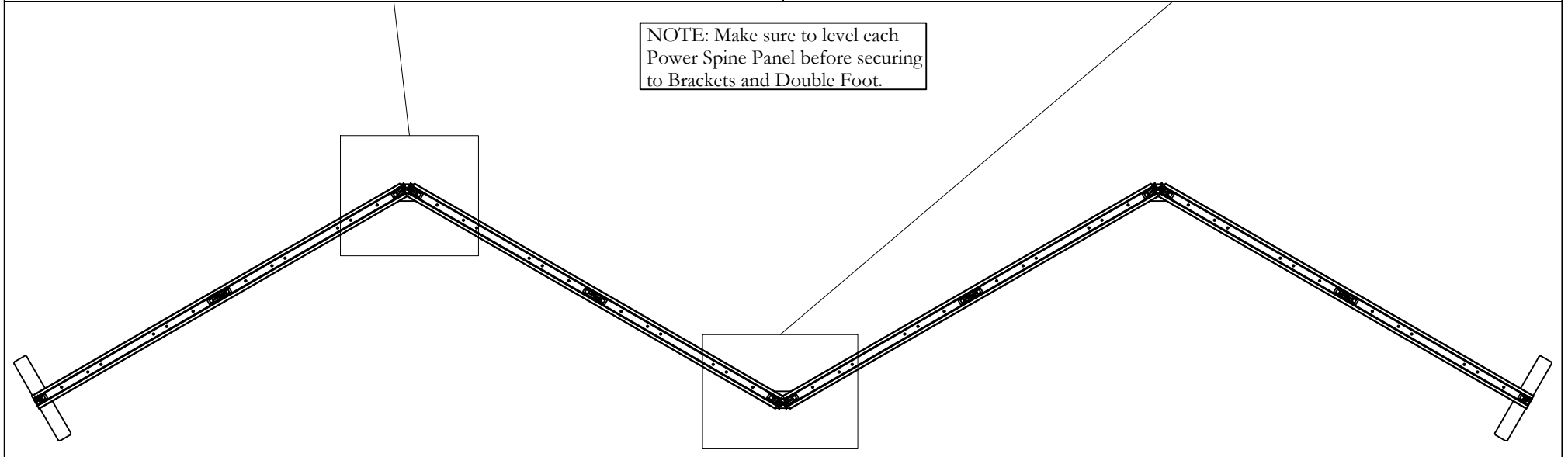

STEP 6: Repeat Steps 1,2, 4 and 5 for the rest of Power Spine Panels. Alternate the orientation of the Power Spine Double Foot to ensure a Zig Zag Pattern. Secure each panel with the 3 brackets above each Double Foot.

NOTE: Make sure to level each Power Spine Panel before securing to Brackets and Double Foot.

REPEAT STEPS 1, 2, 4 AND 5

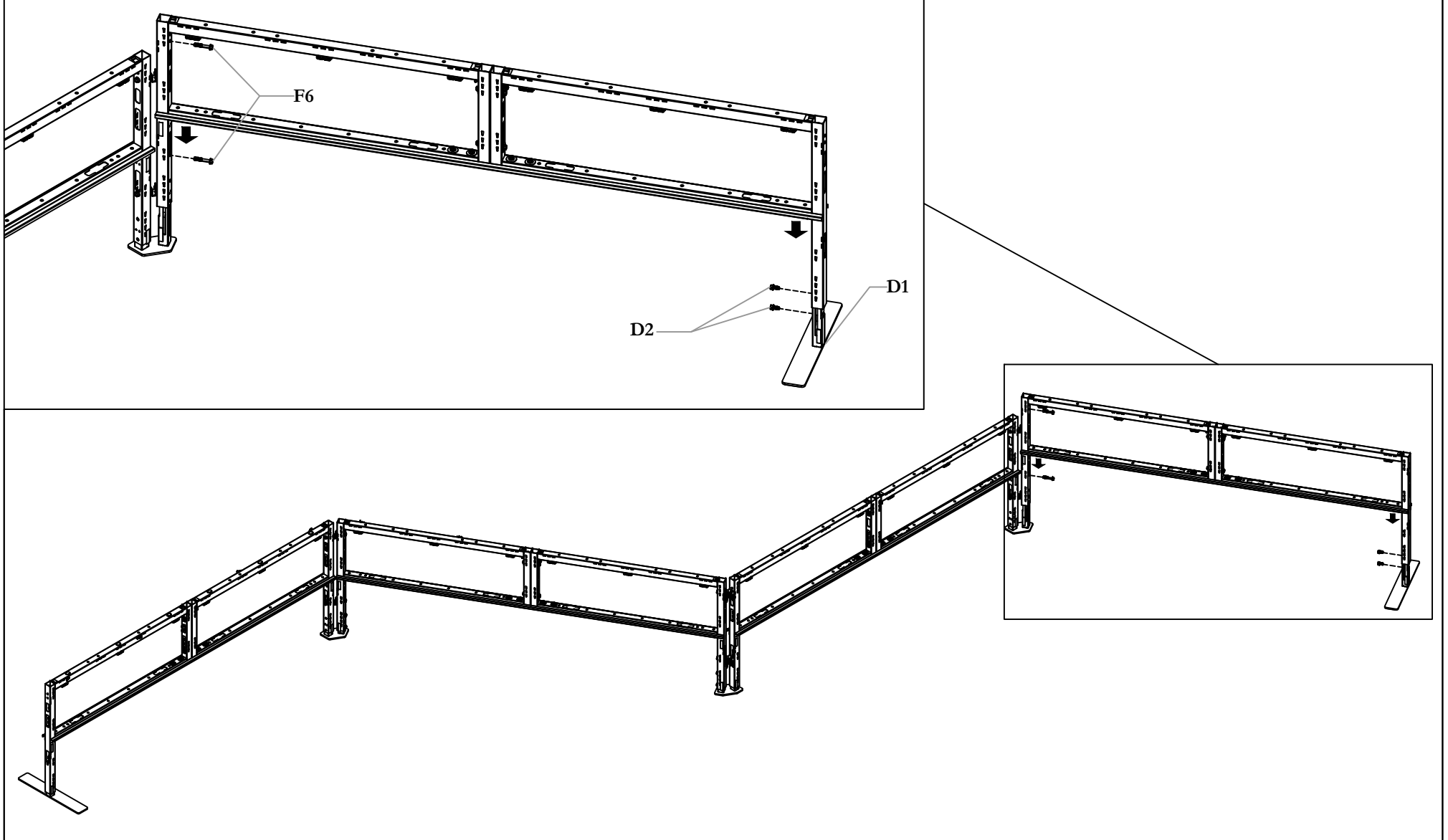

STEP 7: The last Power Spine Panel's outside leg will use the remaining Power Spine Foot (D1).

INSTALL END TRIM

NOTE: Refer to DIS_401 for End Trim Installation Instructions.

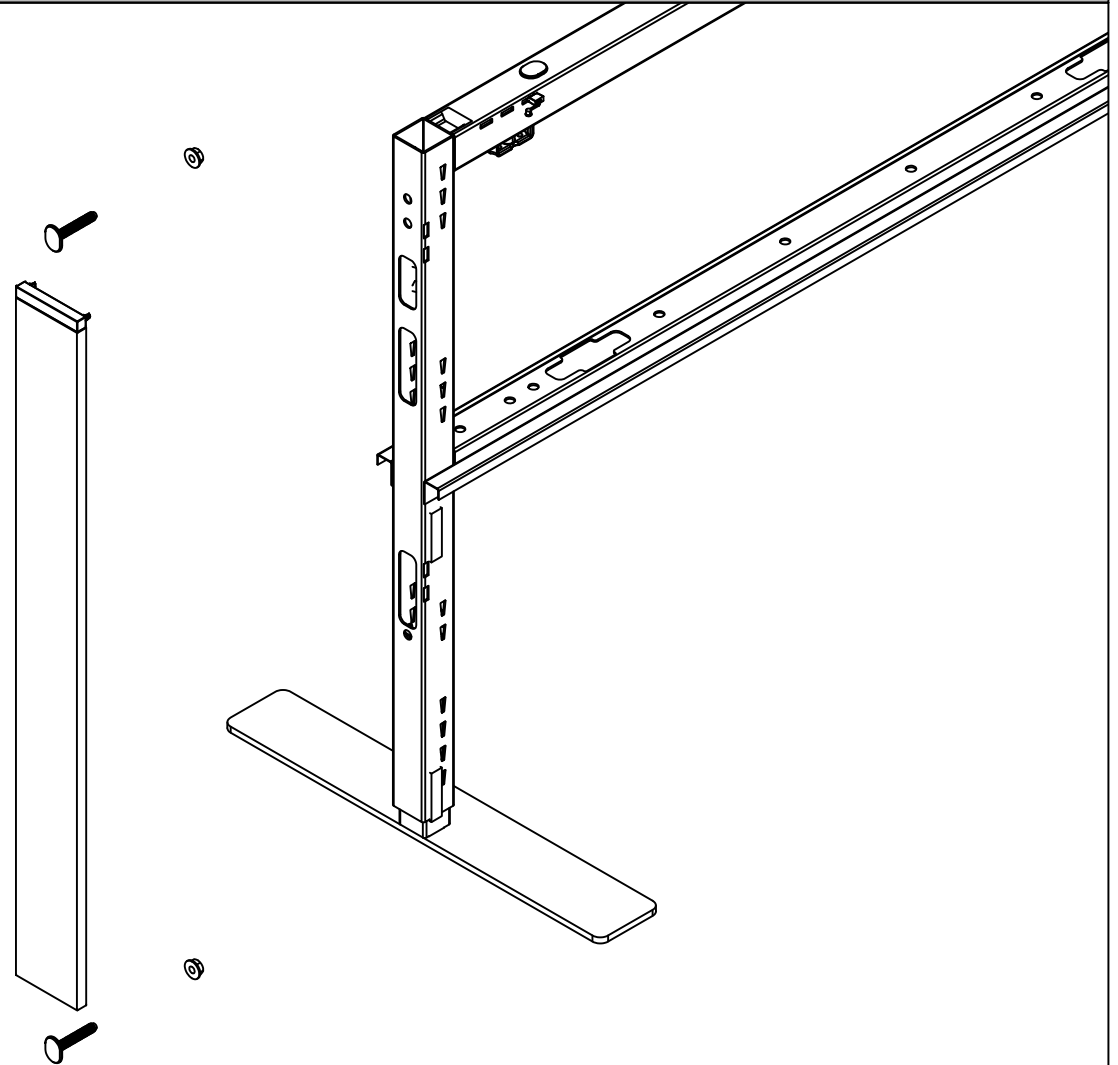

STEP 8: Install End Trim.

NOTE: Refer to DIS_401 for End Trim Installation Instructions.

Section: **PANEL WALLS - POWER SPINE**

Description: **ZIG ZAG POWER SPINE PANEL**

INSTALL BOTTOM TRIM - 1

NOTE: Corner Light Block will be secured by being pushed in by the Bottom Leg Covers.

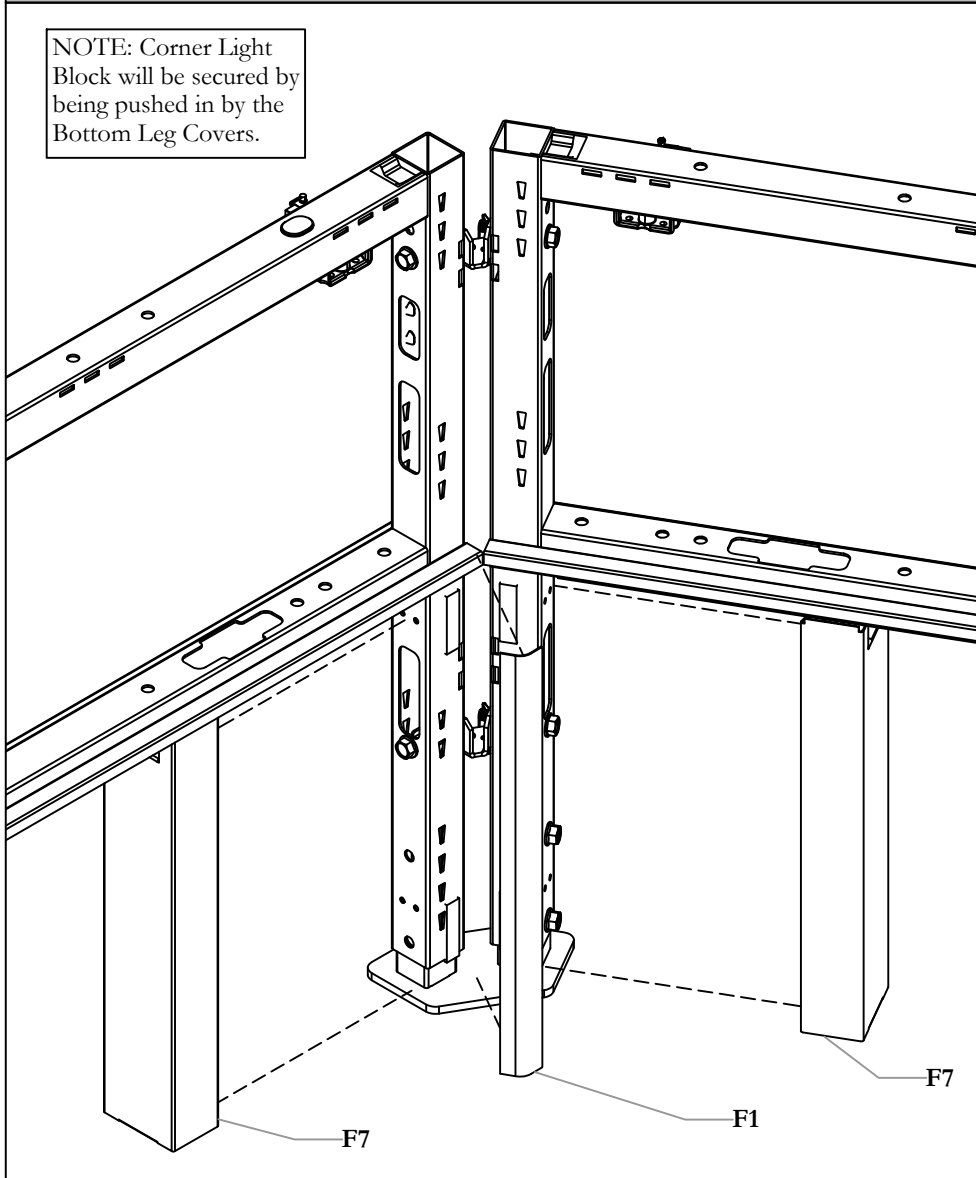

STEP 9a: Install the Corner Light Block (F1) and secure it by installing the Power Spine Leg Cover (F7) to hold it in place. Repeat this for all Double Foot corners.

NOTE: Corner Light Block will be secured by being pushed in by the Bottom Leg Covers.

INSTALL BOTTOM TRIM - 2

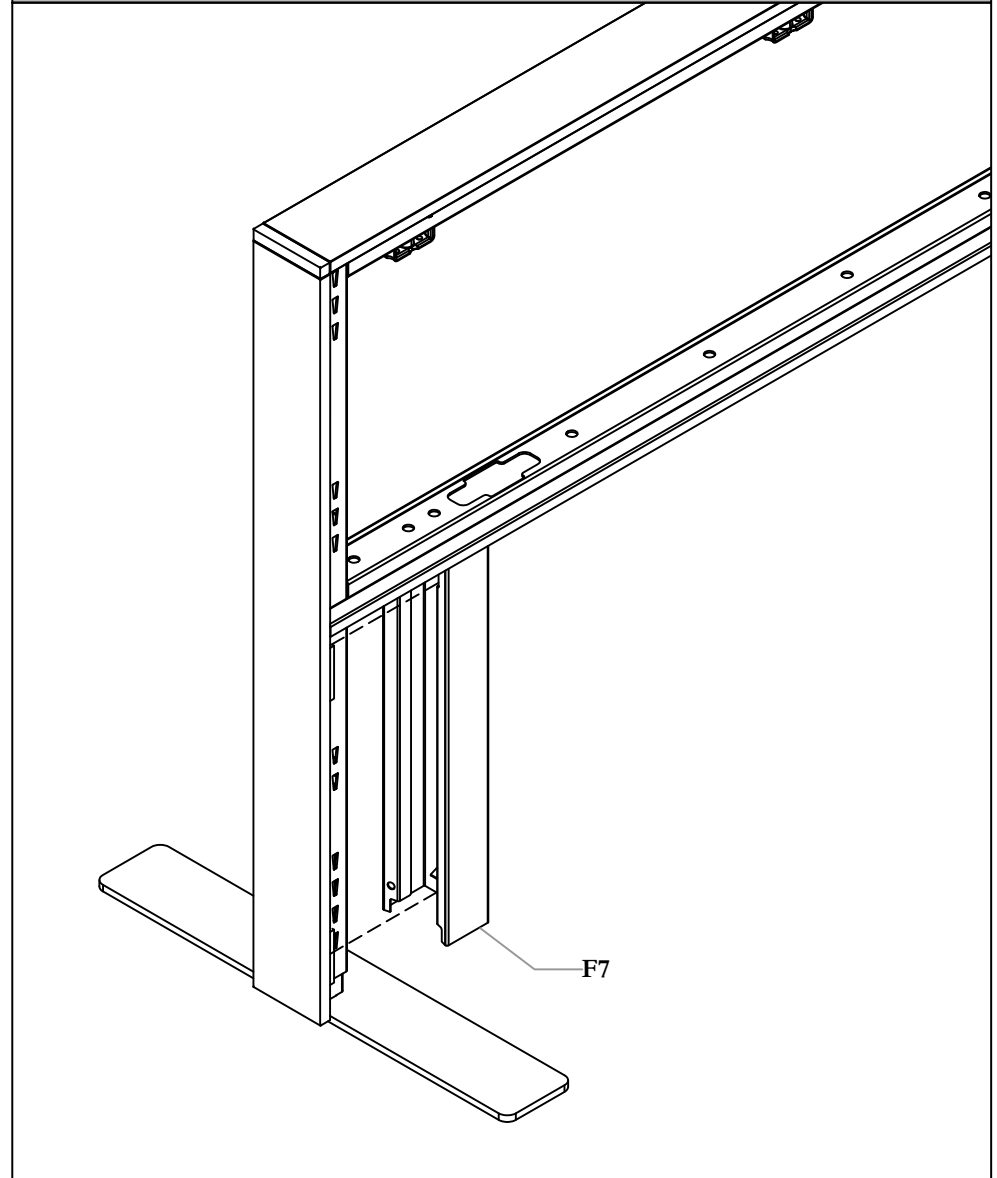

STEP 9b: Install the Power Spine Leg Covers (F7) at each End Power Spine Foot.

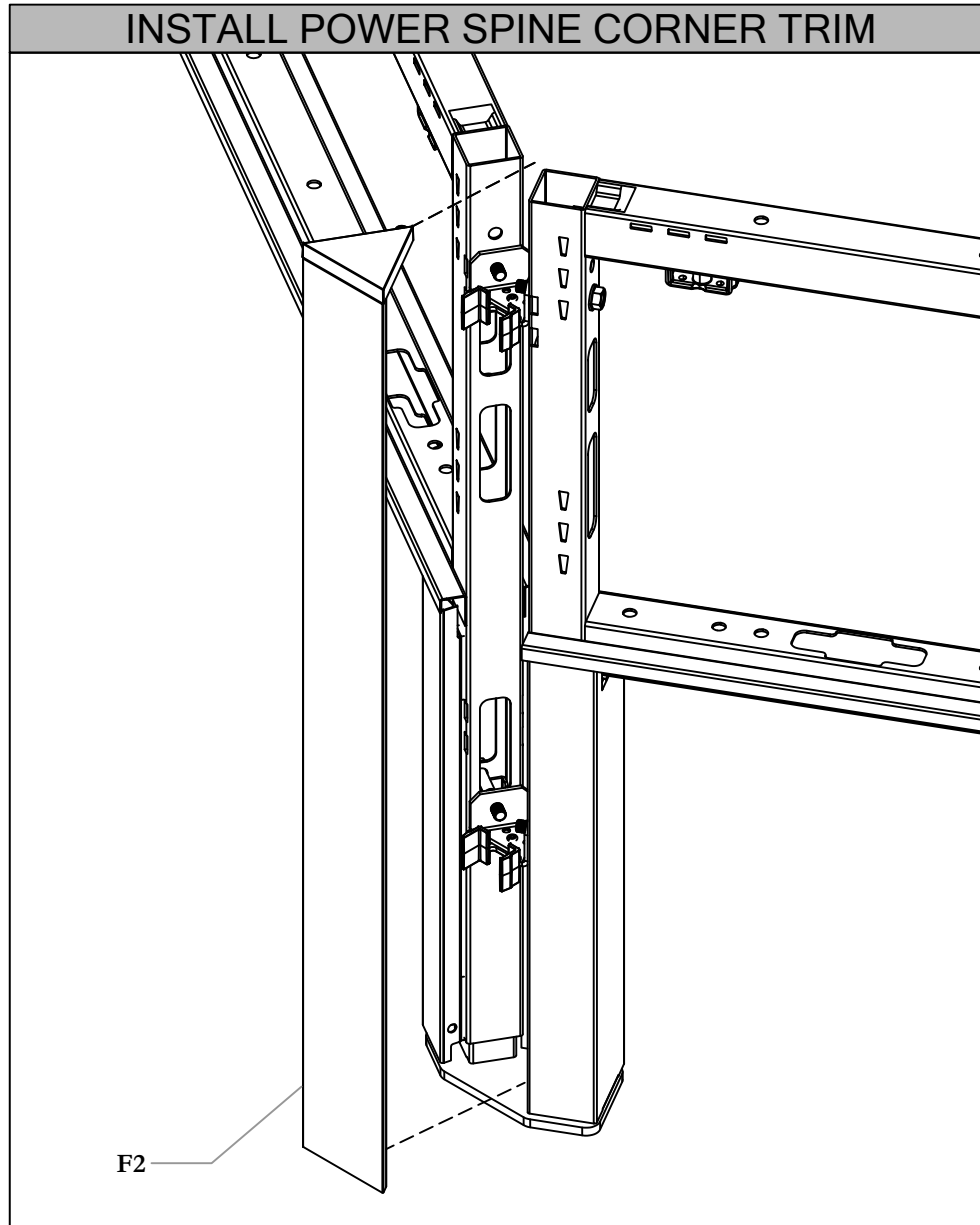

STEP 10: Install Power Spine Corner Trim (F2). The Corner Trim snaps onto the Bracket Clips. Repeat for all Power Spine Corner Trims (F2).

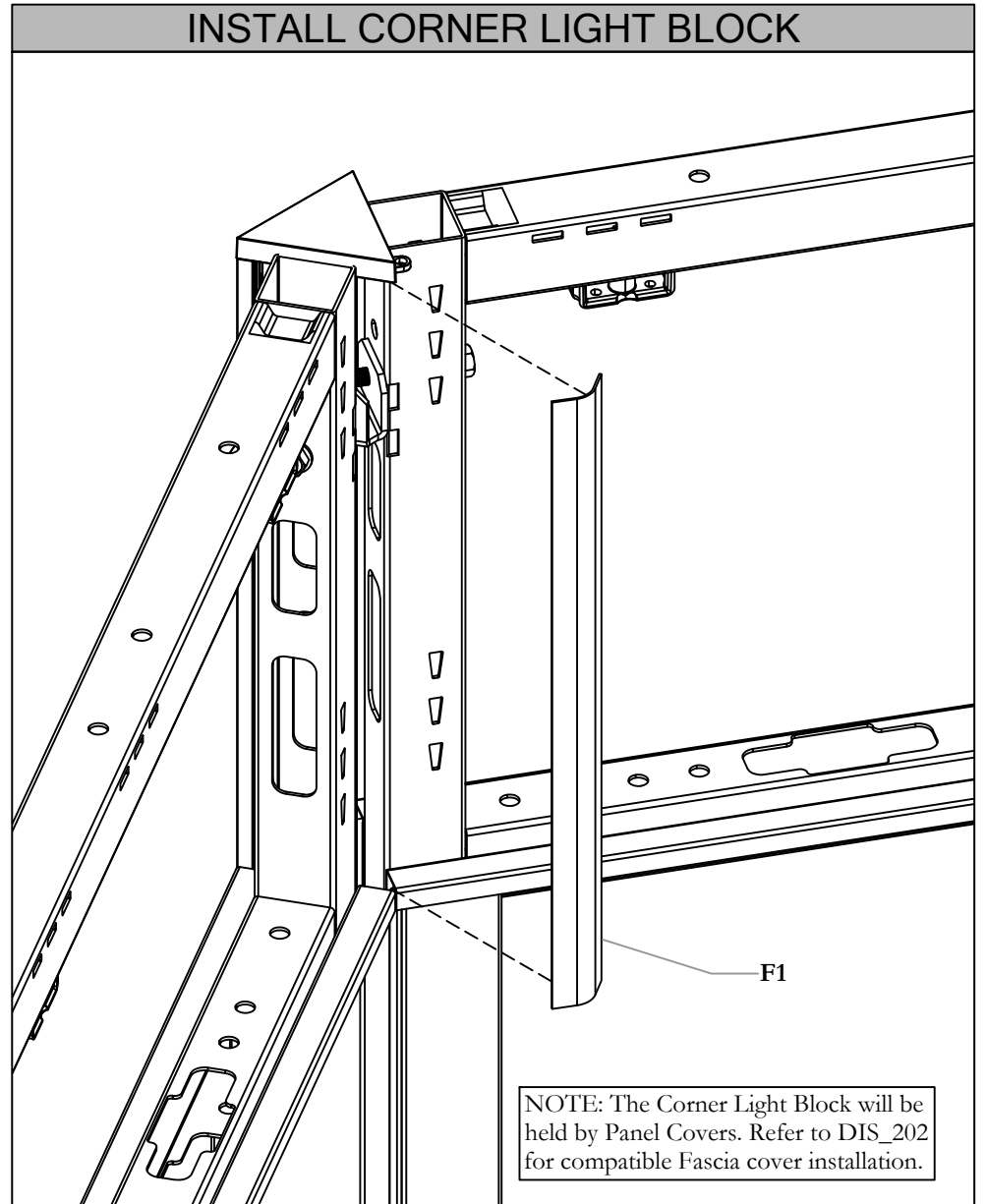

NOTE: The Corner Light Block will be held by Panel Covers. Refer to DIS_202 for compatible Fascia cover installation.

STEP 11: Install Corner Light Block (F1) between the Power Spine Panel between Power Spine Panels. Repeat for all Corner Light Blocks.

NOTE: The Corner Light Block will be held by Panel Covers. Refer to DIS_202 for compatible Fascia cover installation.





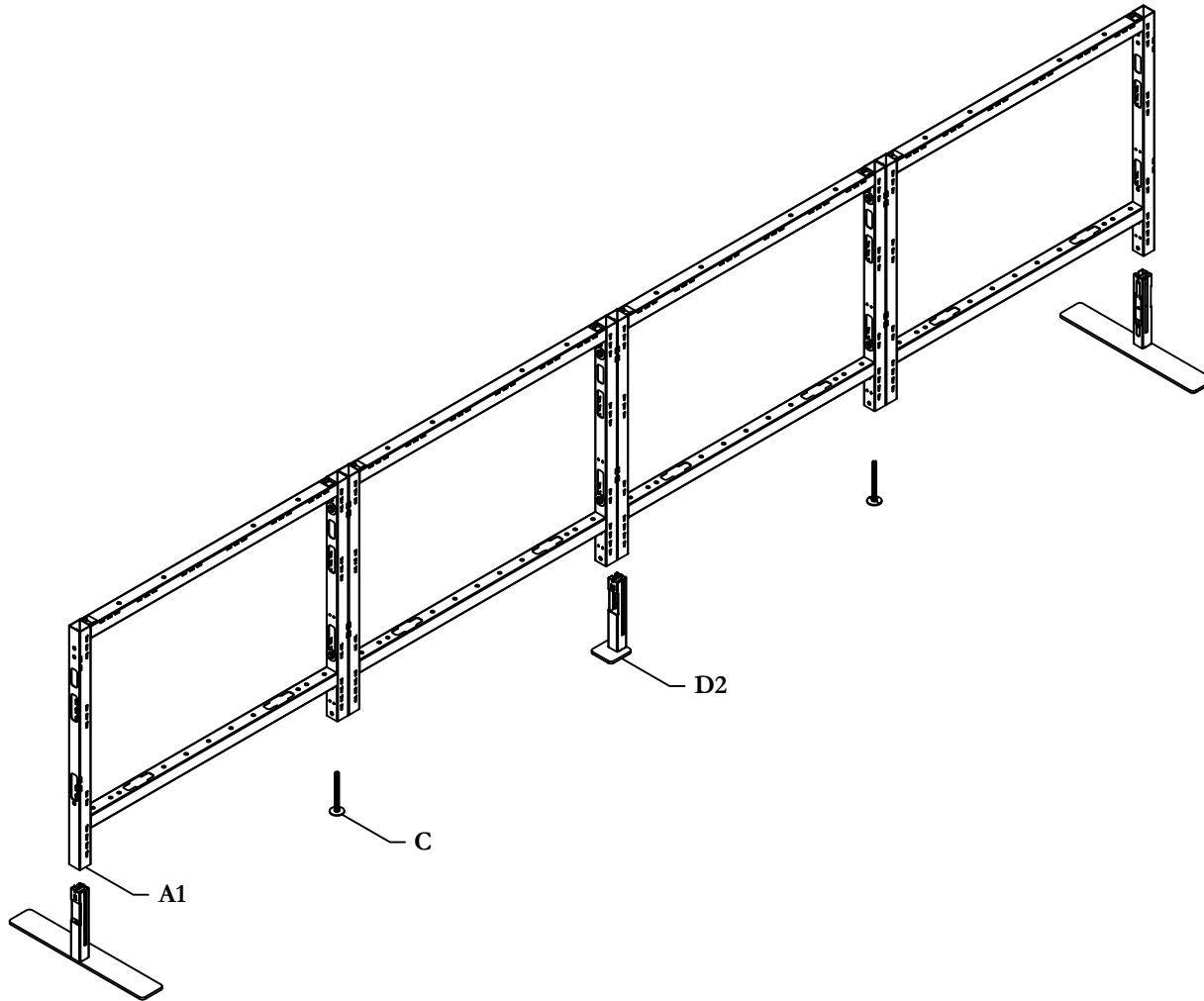

Section: **PANEL WALLS**

Description: **FLOOR FLUSH POWER SPINE**

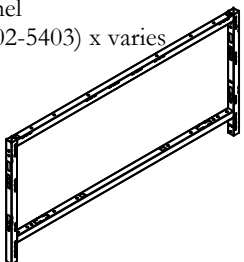
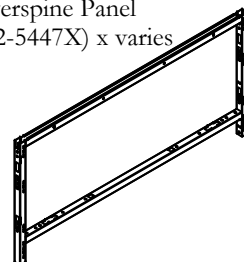
Floor Flush Power Spine(UNFF), Floor Flush Inset Power Spine(UYFF), & Floor Flush Power Spine Support Kit(UZFF)

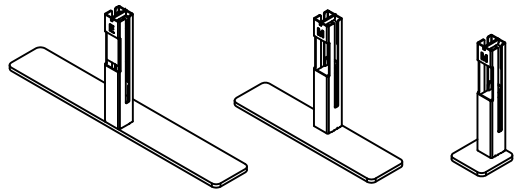

Part and Product Identification

	UNFF	UYFF
	A1 - Floor Flush Powerspine Panel (N02-5403) x varies 	A2 - Inset Glass Floor Flush Powerspine Panel (N02-5447X) x varies 
B - Attachment Hardware (X01-1747) x varies	B1 - FB_5/16-18_3.5_ST_ZN_HX (E03-0430) x varies 	
	B2 - FW_0.344x1.250x0.062_ZN (E03-0457) x varies 	
	B3 - LN_5/16-18_ST_ZN_RR (E03-0437) x varies 	
	C - Panel Leveller (D03-0124) x varies 	
D - Foot Assembly (N02-5365, N02-5650, N02-5650) x varies	D1 - CS_5/16-18x0.750_ST_ZN_HX (E01-0997) x varies 	
	D2 - Foot Assembly (N02-5365\18) x varies (N02-5650\12) x varies (N02-5650\03) x varies 	

FRAME ASSEMBLY

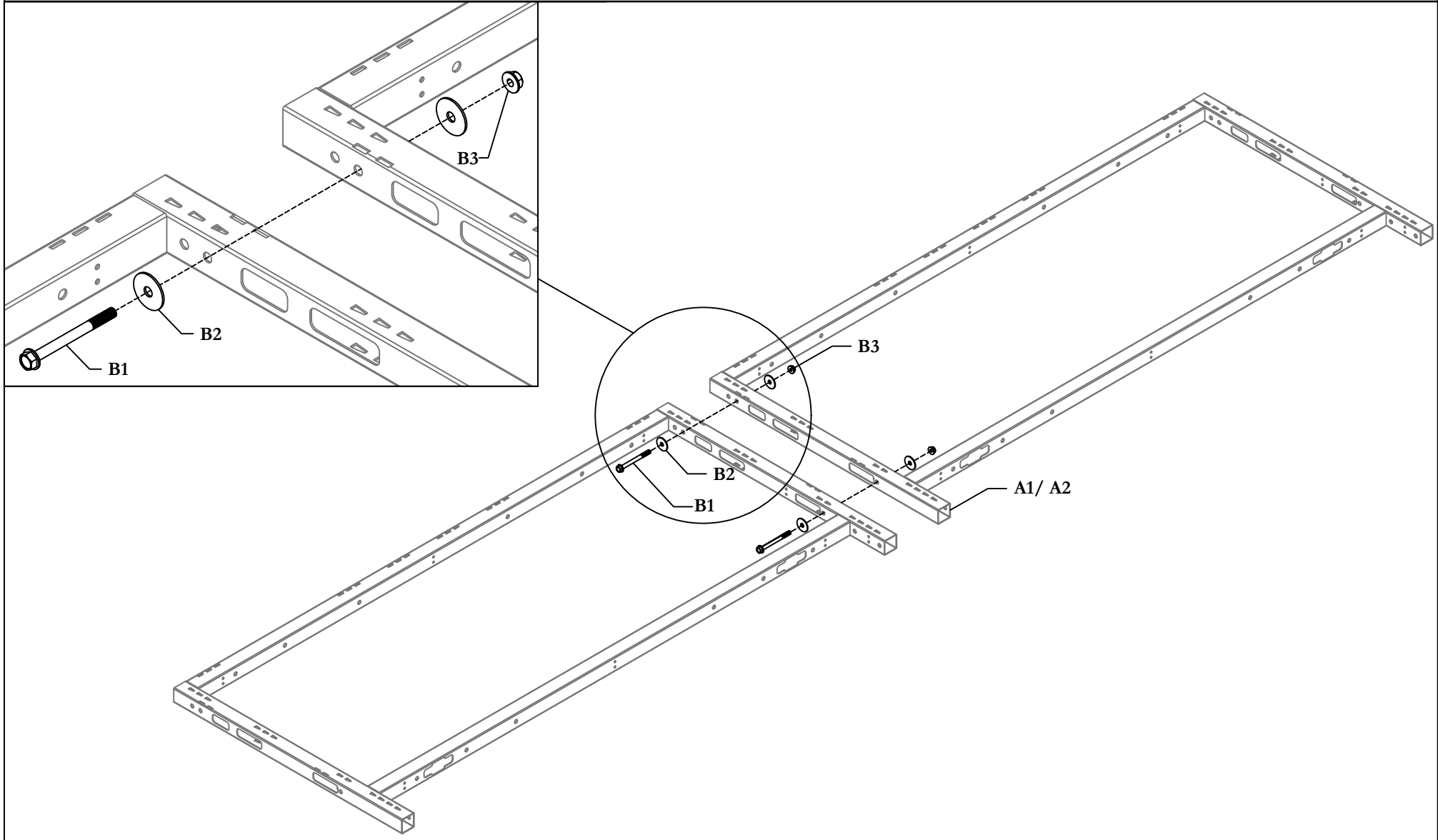

STEP 1: Align holes on both Frames, then secure with Bolt, Washers and Nuts (B1,B2, & B3) as shown. There might be 2 or 3 of these sets depending upon the height of the panel.

PANEL LEVELER INSTALLATION

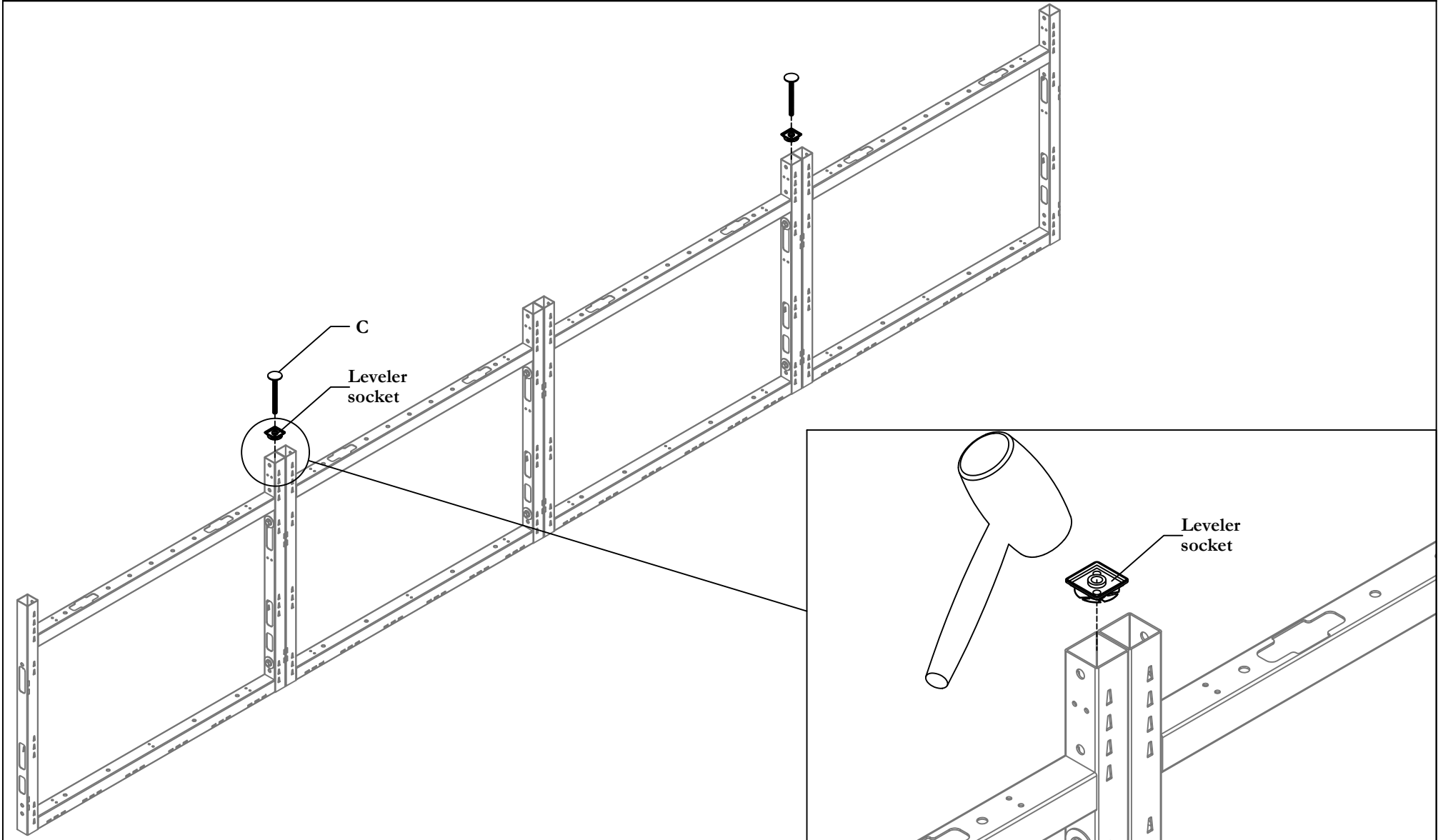

STEP 2: To install the leveler socket flip the panel and insert it at the bottom of the frame using hammer. Then screw in the panel leveler(C).

Section: **PANEL WALLS**

Description: **FLOOR FLUSH POWER SPINE**

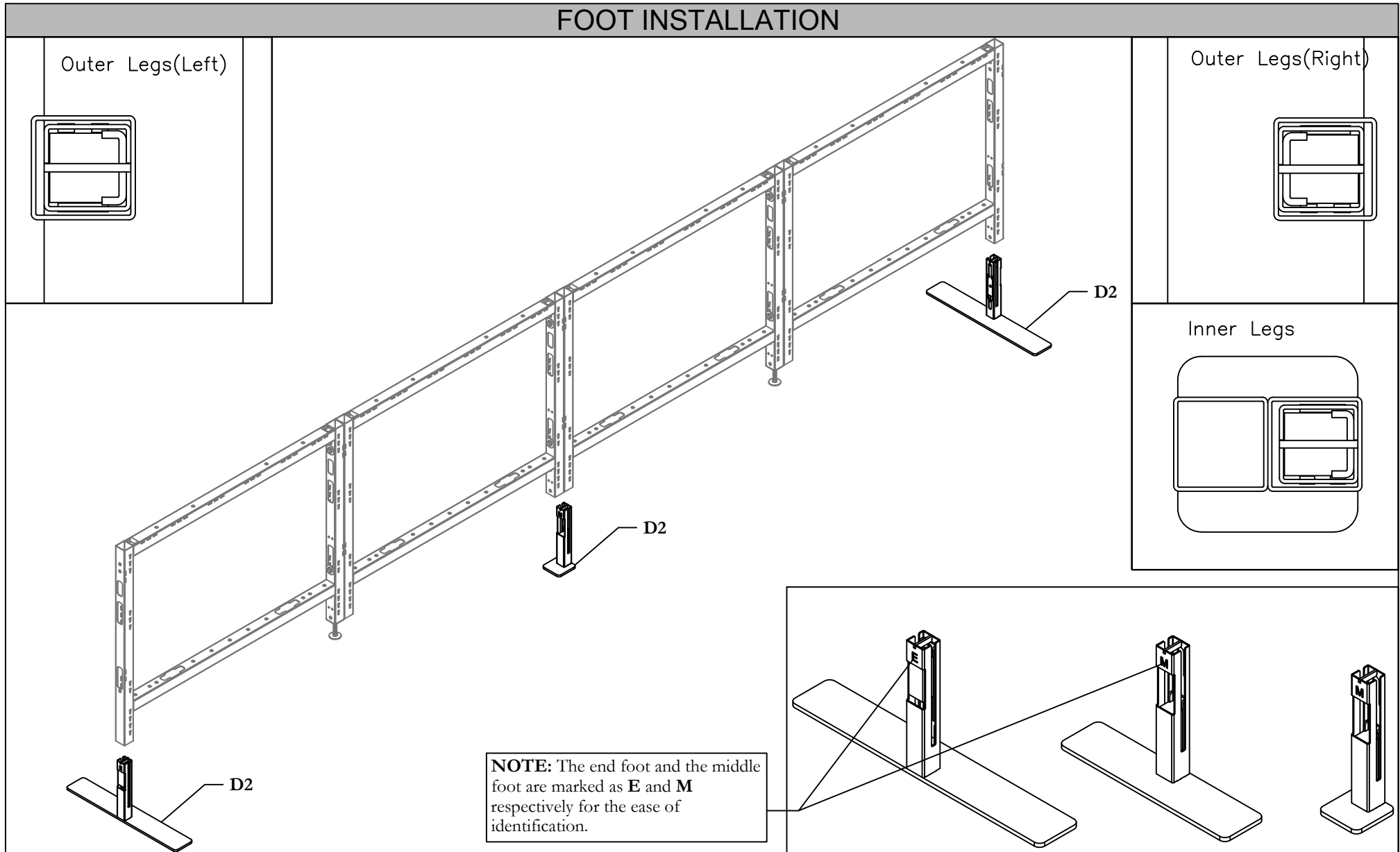

STEP 3: Slide the foot (D2) into the bottom of the frame.

FOOT INSTALLATION

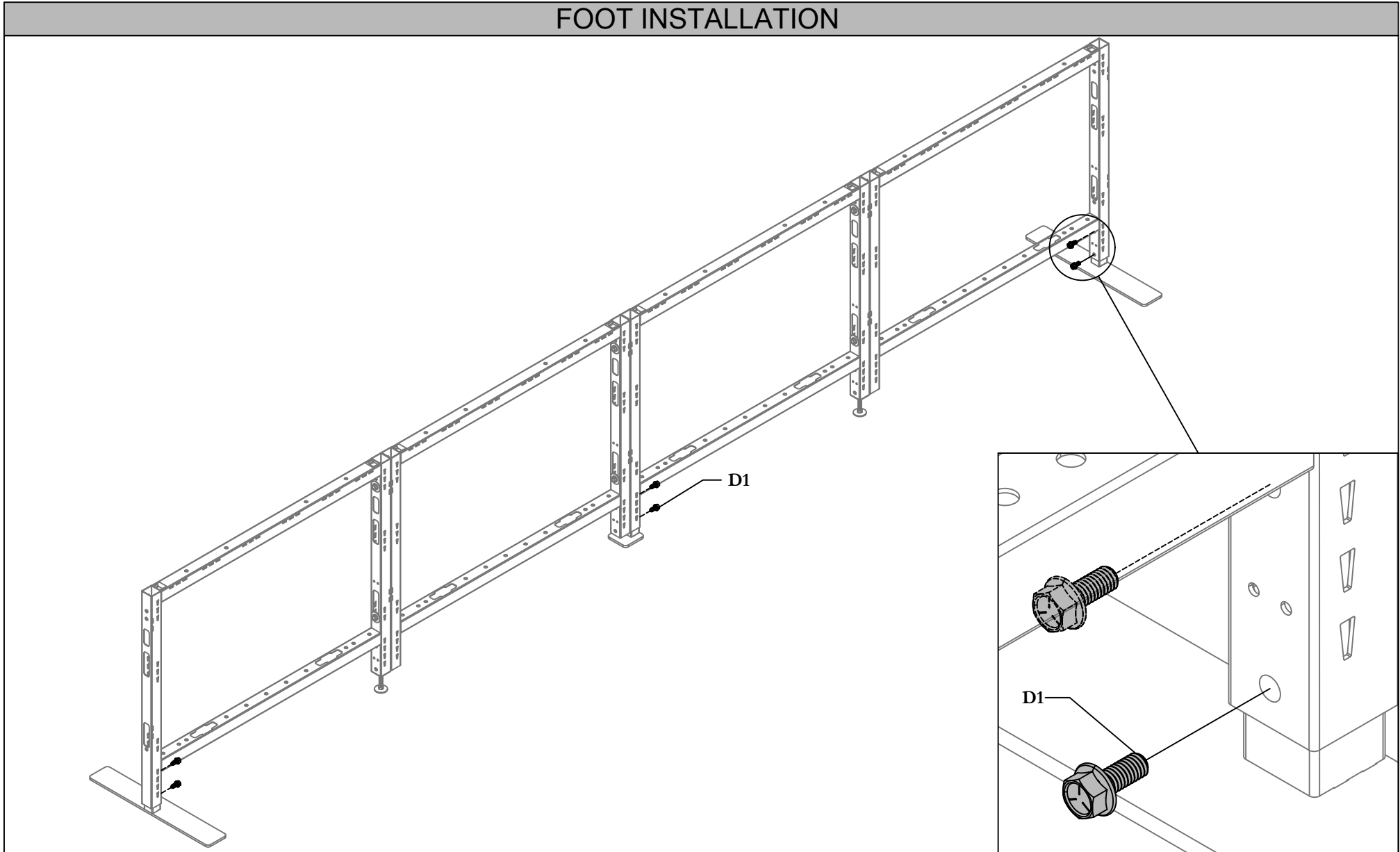

STEP 4: Level the Panel Run and check the perpendicularity, before fastening with the provided screws (D1).

Open Frame 29"H Panel - Standard (UNAF) & Open Frame 29"H Panel - Inset (UYAF)

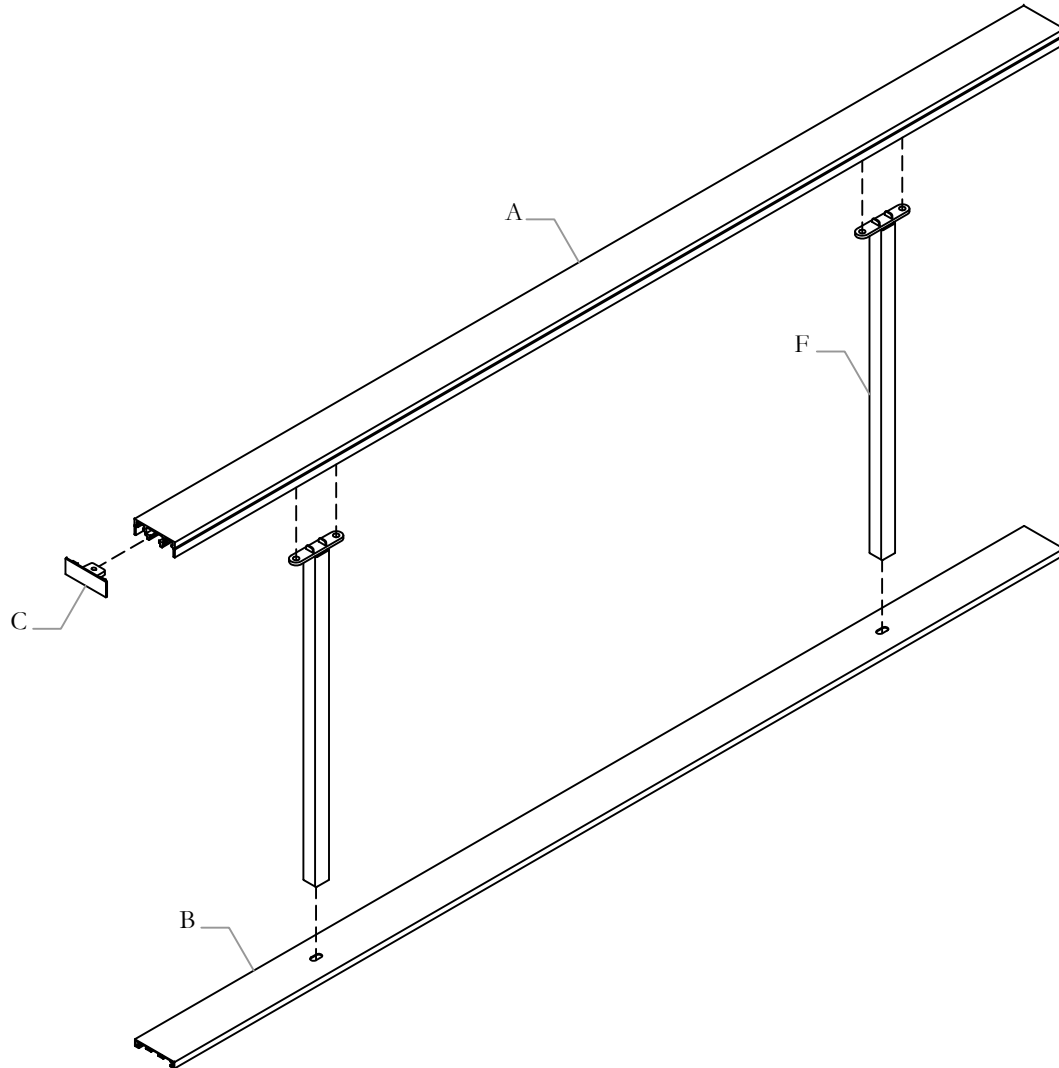

Part and Product Identification

	A - Top Rail for Open Frame (A23-9360-X) x1	
	B - Top Trim for Open Frame (A23-9338-X) x1	
	C - Open Frame Rail End Cap (A25-0846) xVaries	
	D - Add-On End Cap Mounting Plate (A16-12295) xVaries	
	E - 5/16" - 18 x 0.625" Screw (E01-1506) xVaries	
	F - Vertical Open Frame Weldment (N02-5402-X) x2	
	G - Mounting Nut (A25-0386) xVaries	
	H - Open Frame Splicer Plate (A16-12294) xVaries	
	I - Top Trim Alignment Biscuit (B02-0238) xVaries	
J - Trim Attachment Hardware (X01-1753) xVaries		J1 - Trim Fastener (D03-0065) x1
		J2 - 5/16" - 18 Lock Nut (E03-0437) x1
	K - Flat Washer (E03-0457) x2	
	L - 5/16" - 18 x 3.5 Bolt (E03-0430) x2	
	M - Inset Spacer for Open Frame (A25-0865) x2 FOR UYAF ONLY	

Section: **PANEL WALLS**

Description: **OPEN FRAME 29"H PANEL- STANDARD & INSET**

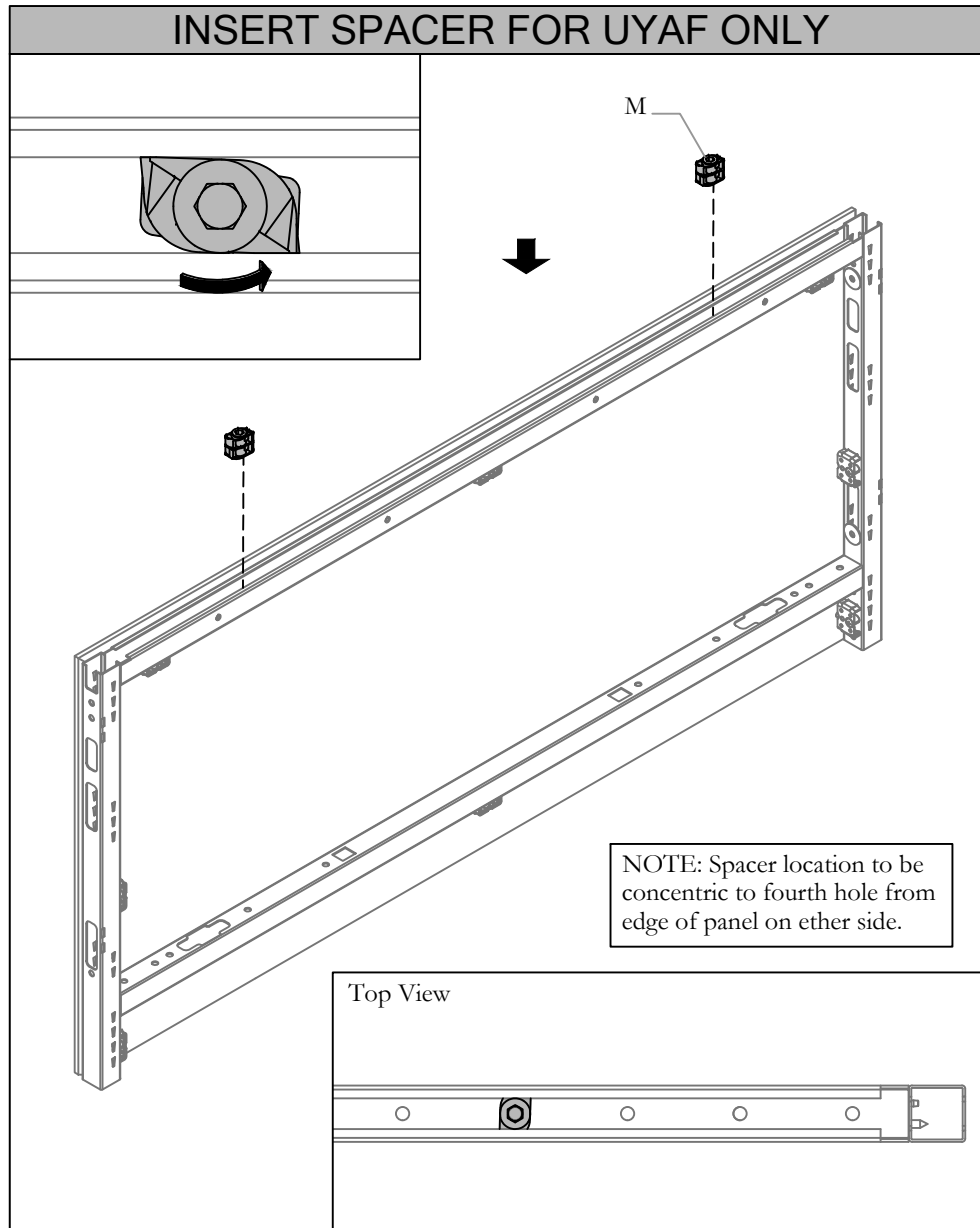

STEP 1: If installing UYAF, insert spacers (M) into Panel and twist Spacers(M) to secure.

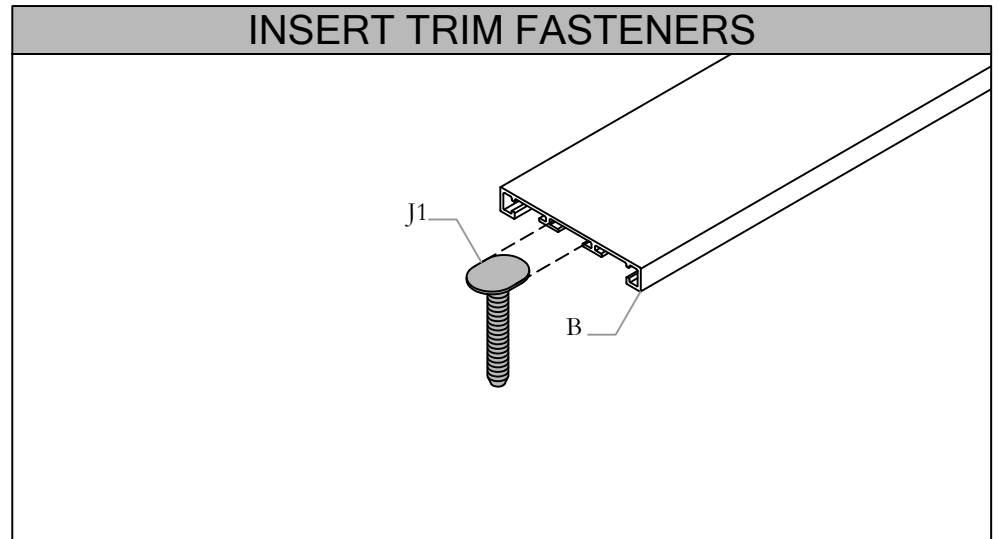

STEP 2: Insert Trim Fasteners(J1) into Top Trim(B).

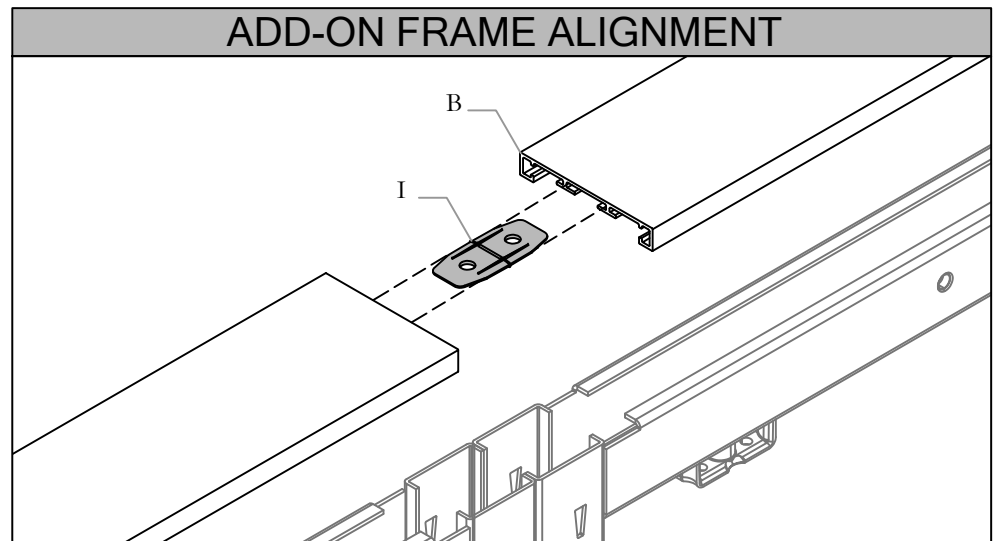

STEP 3: If installing additional Frames side by side, align them by using a Top Trim Alignment Biscuit(I) before dropping on the top of the Panels.

ATTACH TOP TRIM TO PANEL

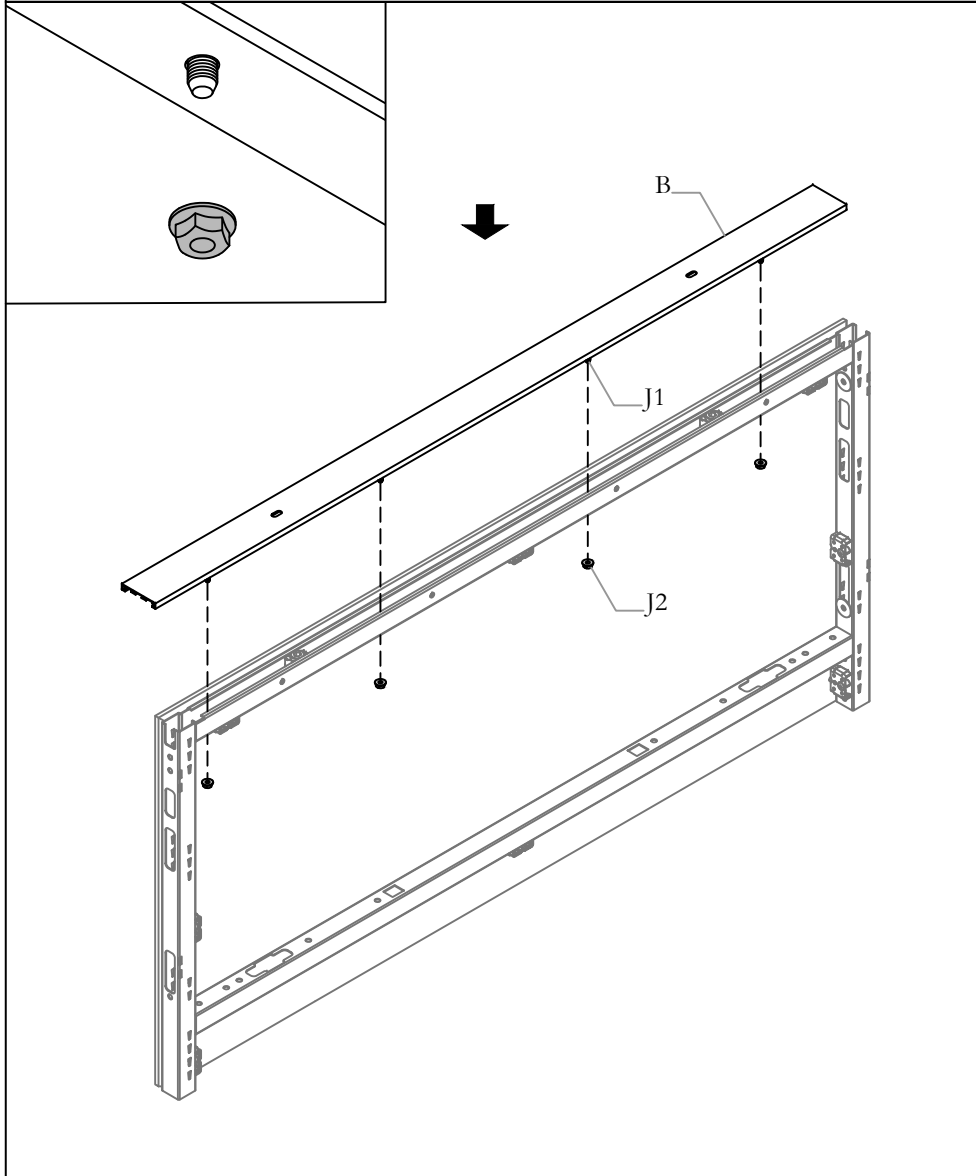

STEP 4: Attach Top Trim(B) to Panel using the inserted Trim Fasteners(J1) and provided Nuts(J2).

ATTACH FRAME AND RAIL TO TRIM

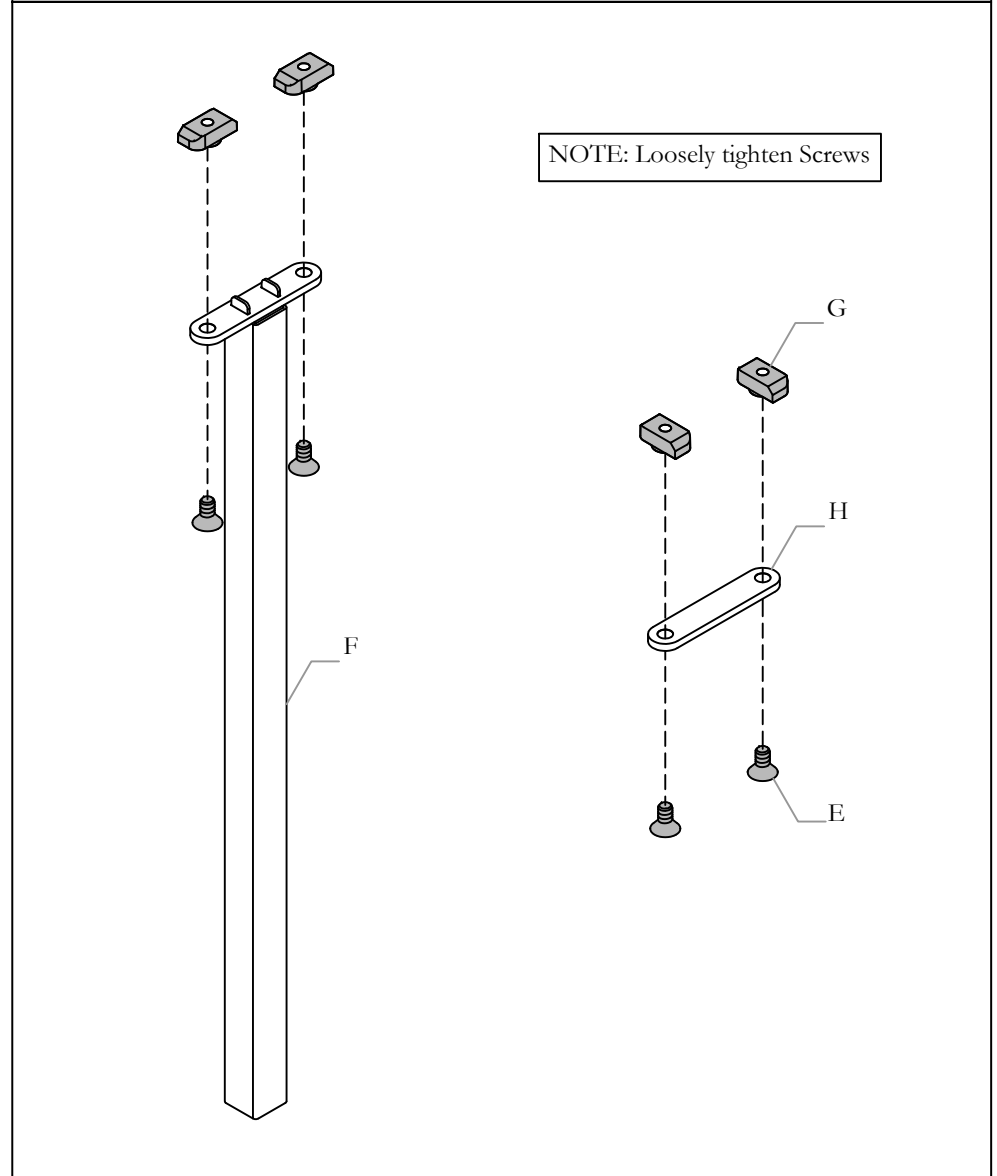

STEP 5: Attach Mounting Nuts(G) to Vertical Open Frame Weldments(F) and Open Frame Splicer Plate(H) by loosely tightening provided Screws(E).

ATTACH FRAME AND RAIL TO TRIM

NOTE: Ensure Post does not scratch Top Trim during installation.

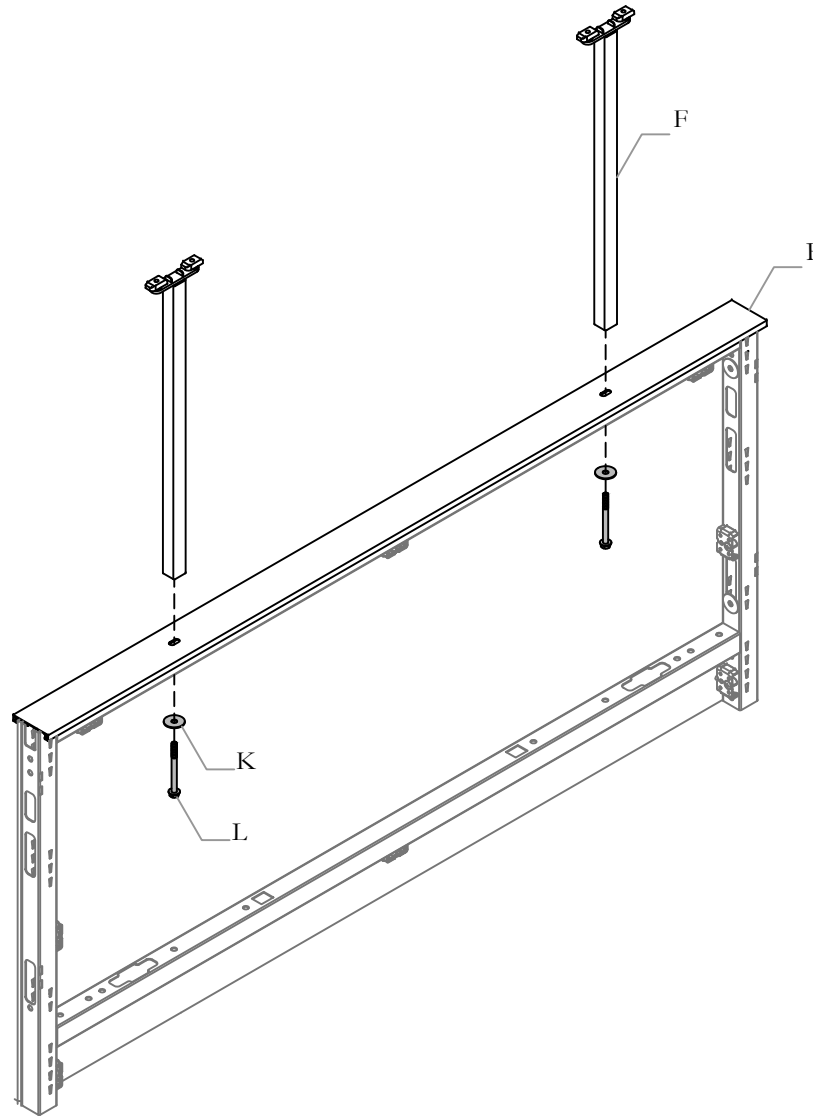

NOTE: Finger tighten Bolts.

STEP 6: Attach Vertical Open Frame Weldments(F) to Top Trim(B) and Panel using provided Washers(K) and Bolts(L).

Section: **PANEL WALLS**

Description: **OPEN FRAME 29"H PANEL-STANDARD & INSET**

INSERT OPEN VERTICAL FRAME WELDEMENT

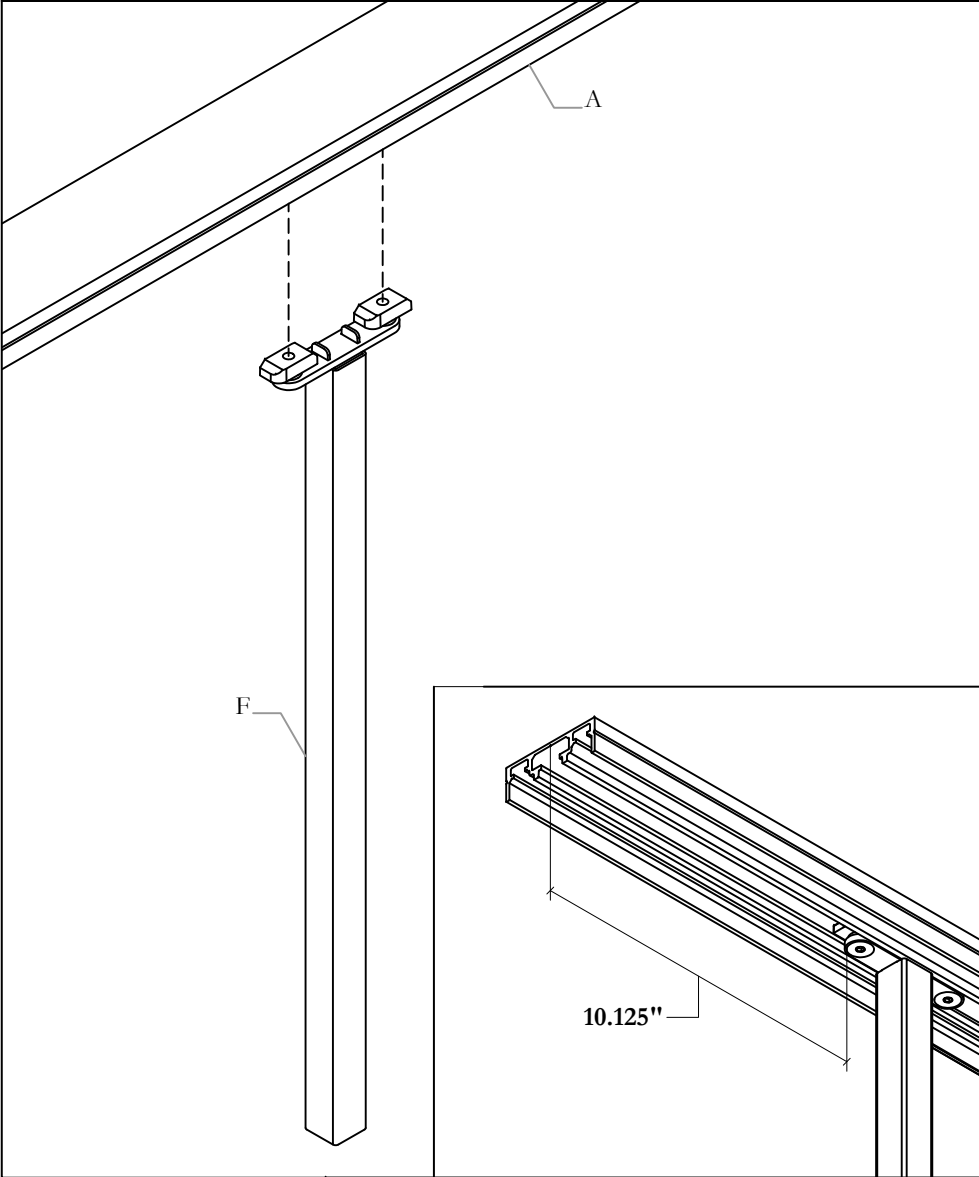

Front View

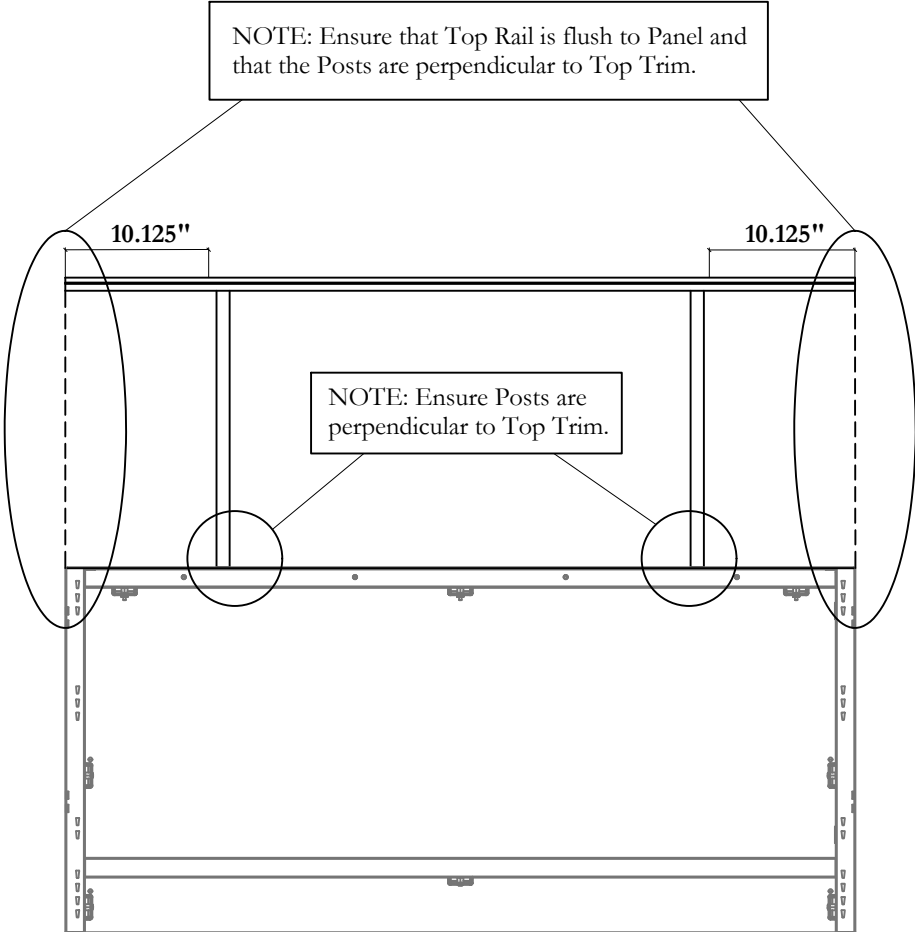

STEP 7: Insert Vertical Open Frame Weldements(F) into Top Rail(A) ensuring that the Weldements are 10.125" from the edge of the Top Rail.

SECURE POSTS

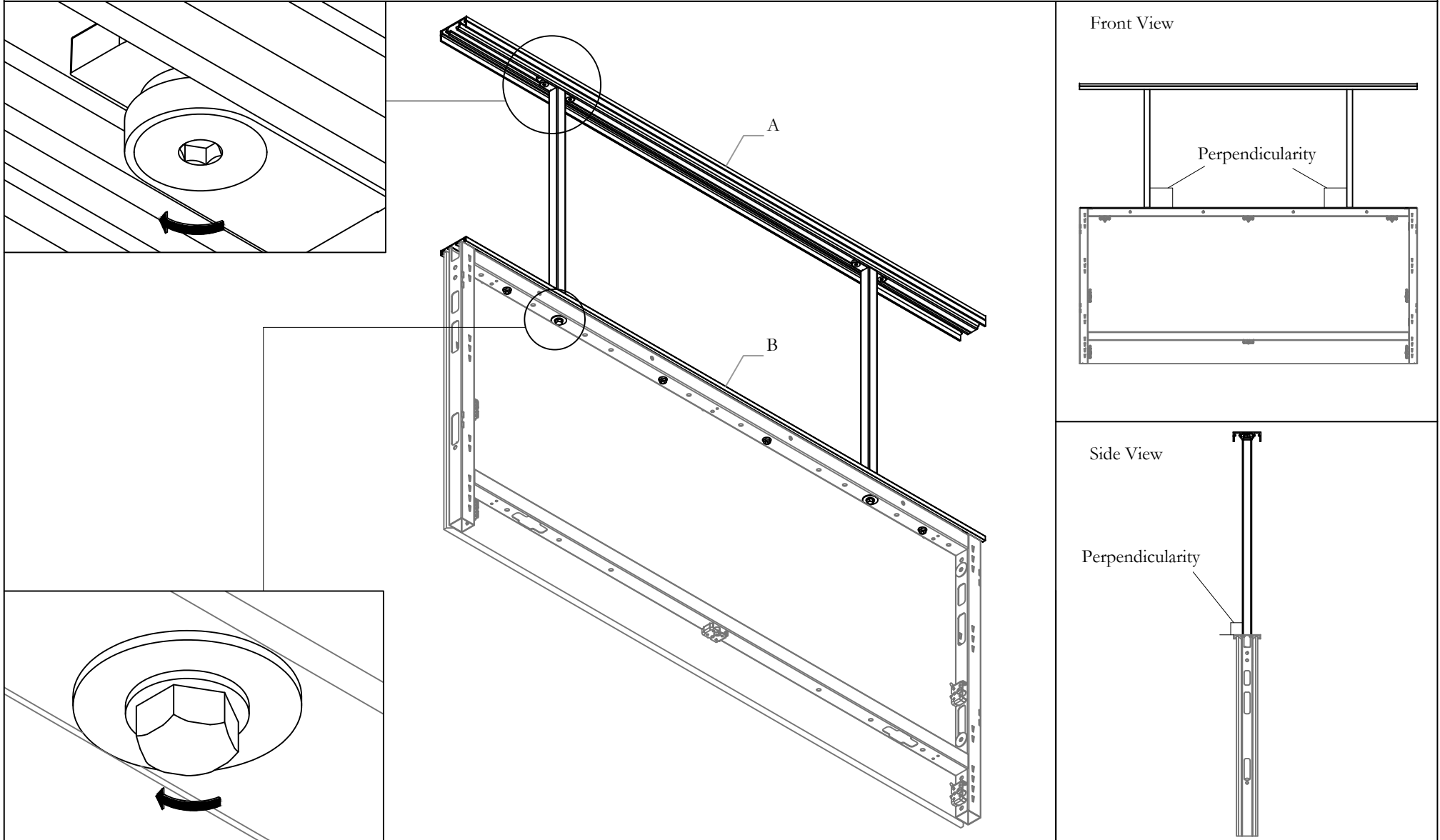

STEP 8: Tighten all Screws to secure Posts to Top Rail(A) and Top Trim(B). Ensure that posts remain flush to Panel and Perpendicular to Top Trim(B).

INSERT SPLICER PLATE

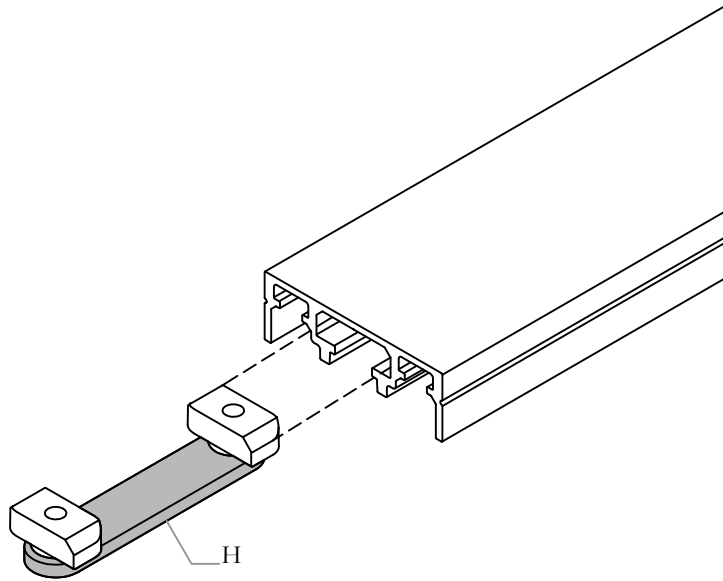

STEP 9: If installing additional Frames side by side, Align them by inserting Open Frame Splicer Plate(H) into Top Rail(A).

INSTALL END CAP

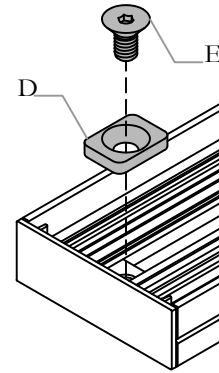

NOTE: Finger tighten then 1/4 turn.

NOTE: For installation of Sliding Screens refer to guide DIS_256.

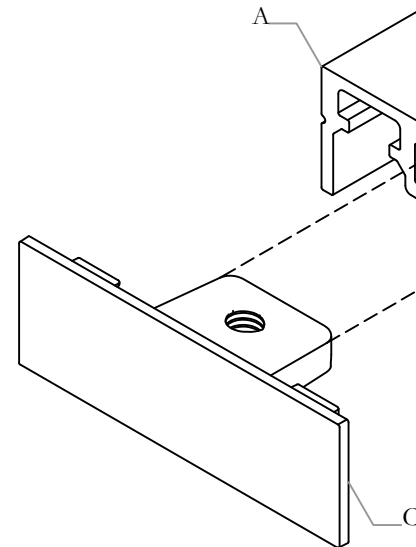

STEP 10: Once all Sliding Screens are installed, install End Caps(C) onto the Top Rail(A) using provided Mounting Plates(A) and Screws(E).

Section: **PANEL WALLS**

Description: **SLIDING SCREEN FOR OPEN FRAME**

Sliding Fabric Screen for Open Frame (UNXF) & Sliding Smooth Felt Screen for Open Frame (UNZF)

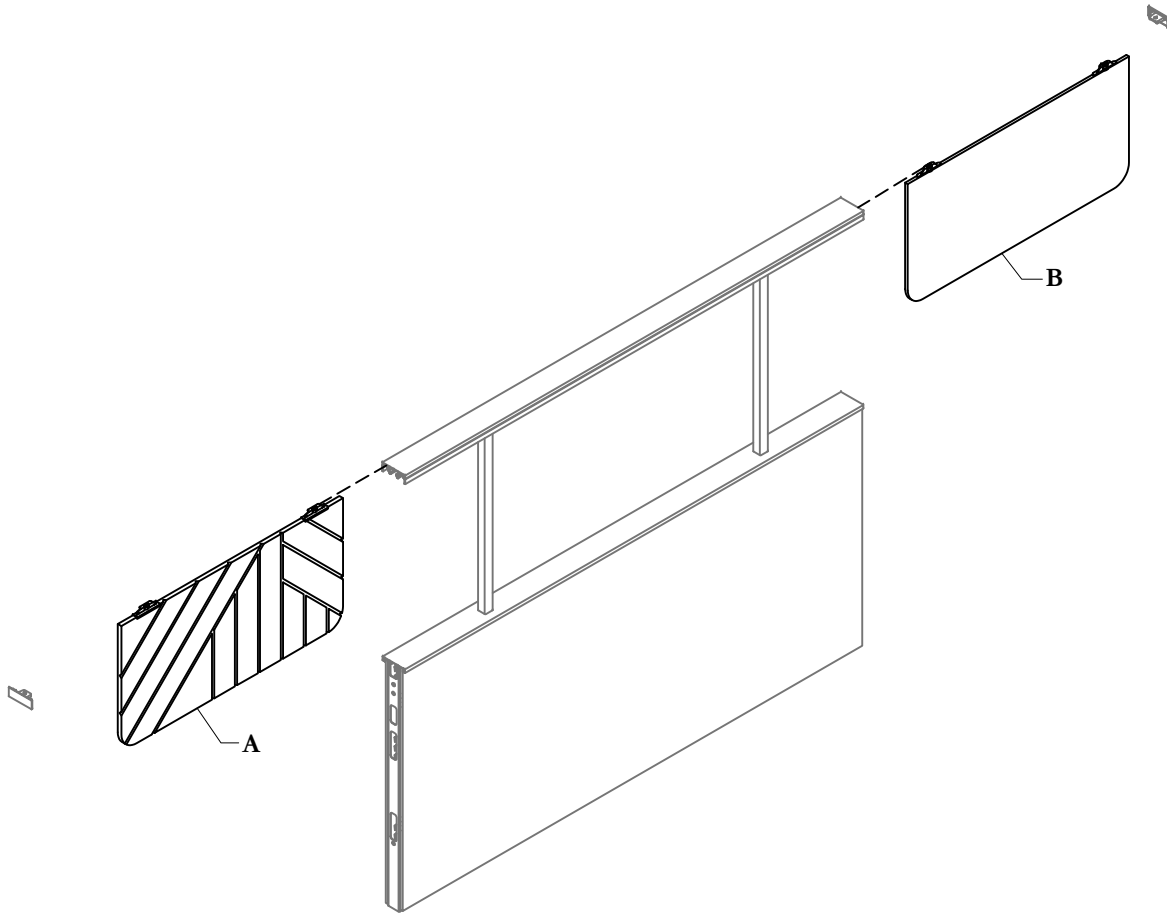

Part and Product Identification

UNZF

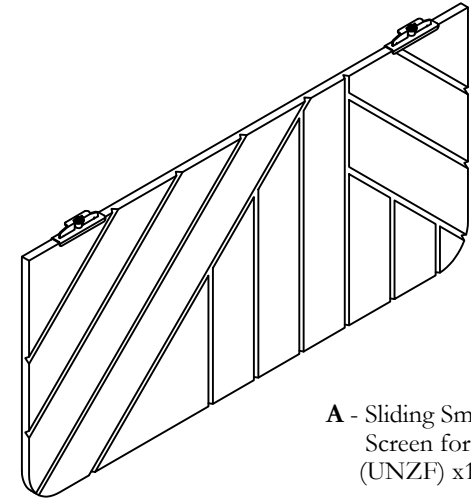

A - Sliding Smooth Felt Screen for Open Frame (UNZF) x1

UNXF

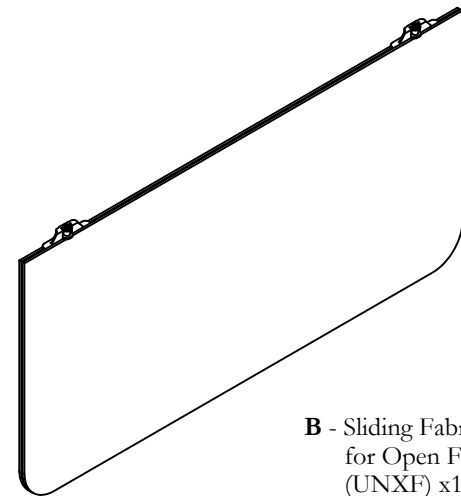

B - Sliding Fabric Screen for Open Frame (UNXF) x1

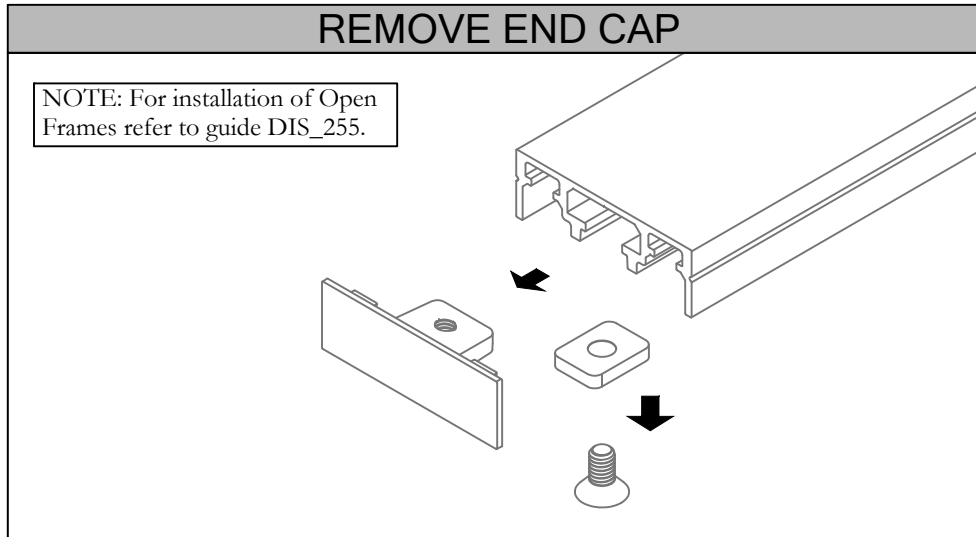

STEP 1: If adding or replacing a Screen to an existing Open Frame, remove the End Cap that is attached to the Top Rail by unscrewing the Mounting Plate.

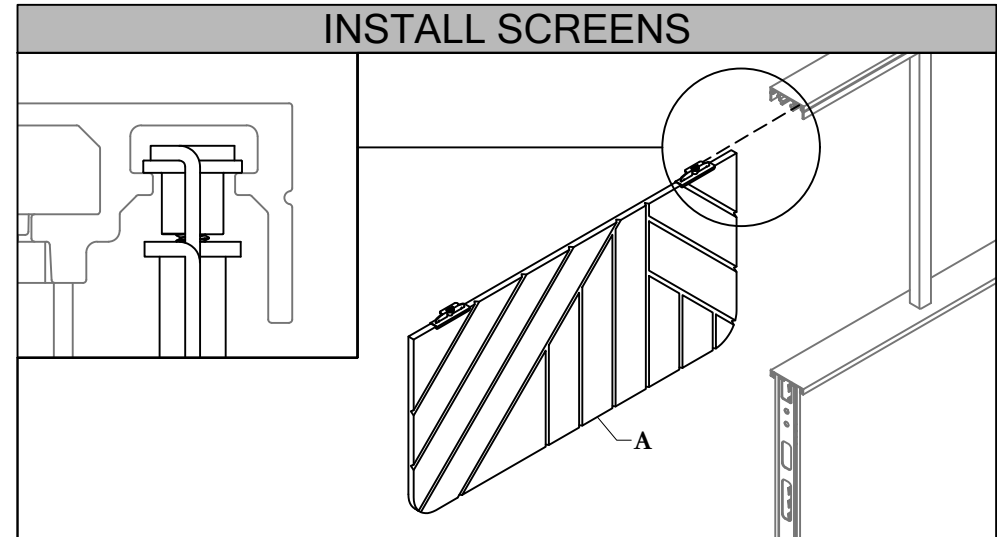

STEP 2: Install the desired Screens onto the Open Frame by Sliding hooks into the outer channels of the Top Rail.

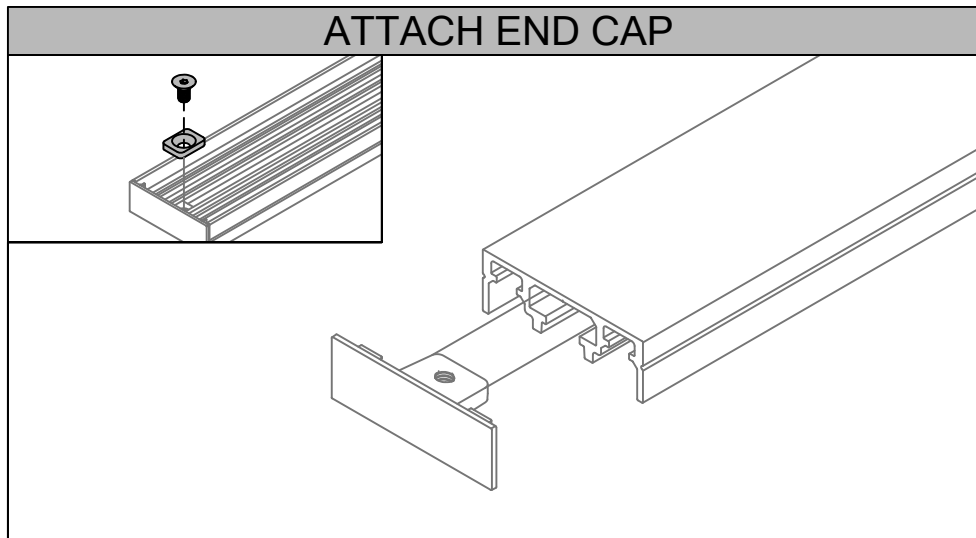

STEP 3: Once all Sliding Screens are installed, install End Caps onto the Top Rail using provided Mounting Plates and Screws.

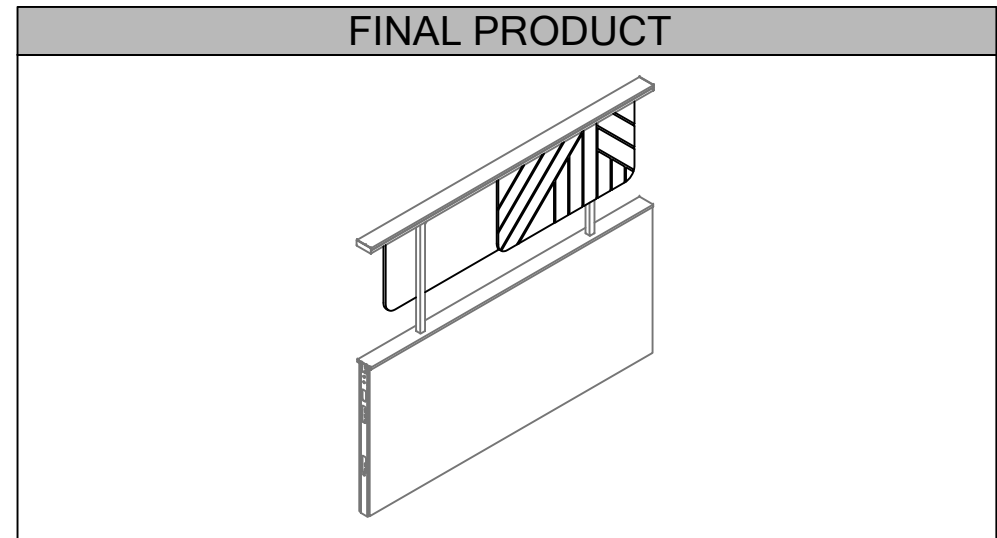

STEP 4: Once the Screens have been installed this is what the final product will look like.

120 Angled WorkSurface (UZWA), 120 WorkSurface Support Bundle (UZWB)

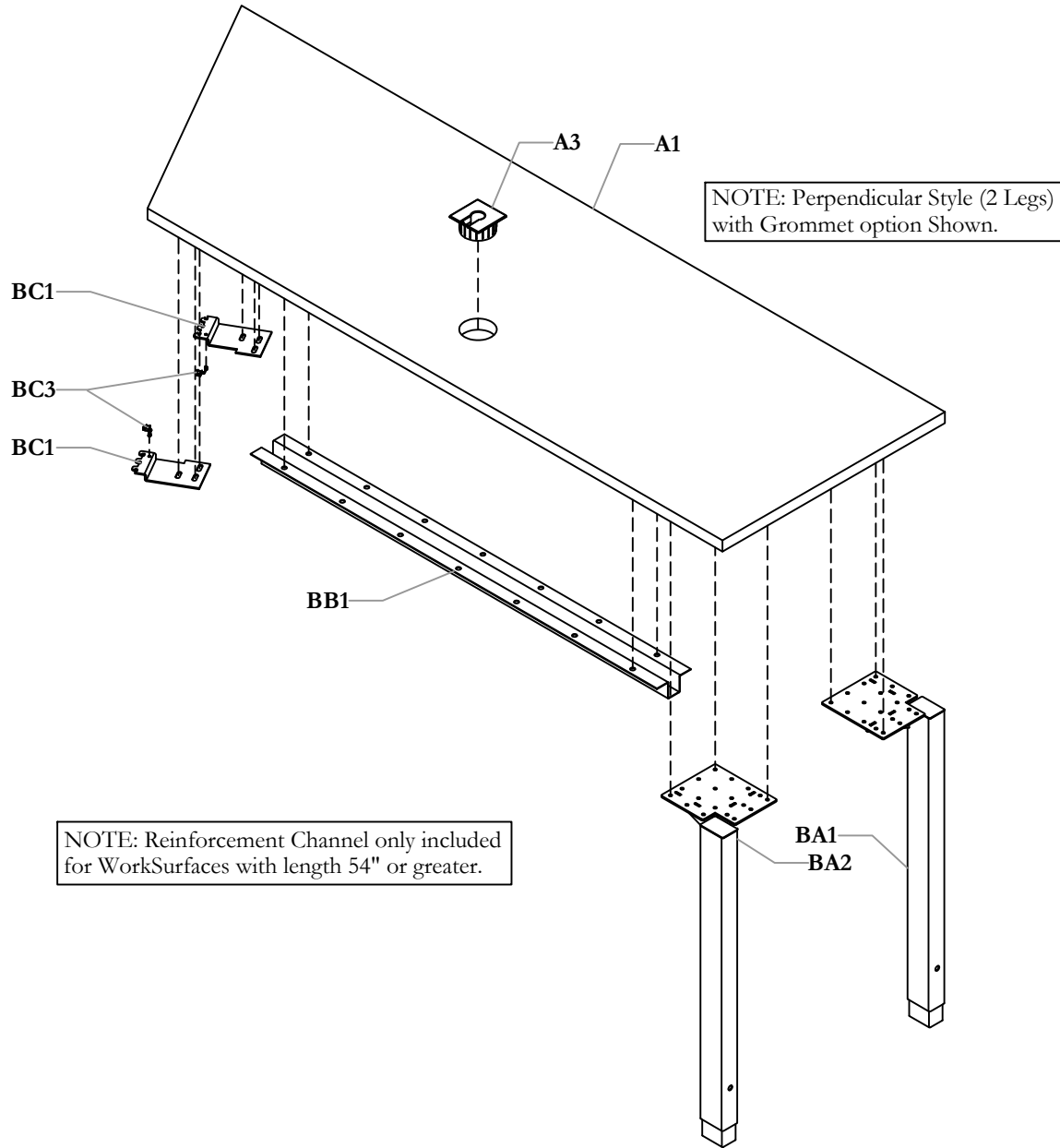

Part and Product Identification

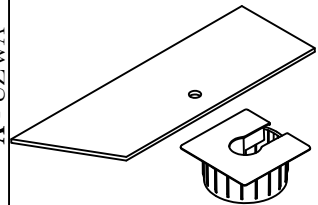
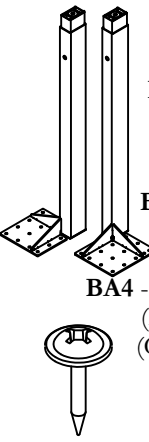
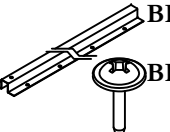
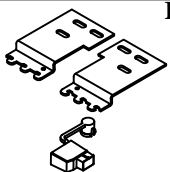
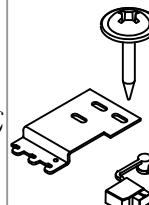
A - UZWA	 <p>A1 - Power Spine Angled Worksurface Perpendicular (C07-8224X-X) x1 OR A2 - Power Spine Angled Worksurface Parallel (C07-8116X-X) x1 A3 - Square Grommet (YEDG2 (N09-1699)) xQty Varies</p>
B - UZWB	 <p>BA1 - Upstage Post Leg - Fix Height - Right (N09-5037R) xQty Varies (Comes Assembled) BA2 - Upstage Post Leg - Fix Height - Left (N09-5037L) xQty Varies (Comes Assembled) BA3 - Upstage Post Leg Cap Assembly (N09-5206) xQty Varies (Comes Assembled) BA4 - Upstage Post Leg Leveler Subassembly (N09-5035) xQty Varies (Comes Assembled) BA5 - #10x0.875" LG. Screw, Quad.Pan Washer (E07-0077) xQty Varies</p>
BB - UNRC	 <p>BB1 - Reinforcement Channel (A15-6956-X) xQty Varies BB2 - #10x0.875" LG. Screw, Quad.Pan Washer (E07-0077) xQty Varies</p>
BC - UNIBP	 <p>BC1 - Worksurface Panel Bracket - Pair (A15-6949L/R) x1 BC2 - #10x0.875" LG. Screw, Quad.Pan Washer (E07-0077) x6 BC3 - Bracket Retainer (B02-0242) x2</p>
BD - Worksurface Panel Bracket Kit (X01-4060L/R) xQty Varies	 <p>BD1 - Worksurface Panel Bracket (A15-6949L or R) x1 BD2 - Bracket Retainer (B02-0242) x1 BD3 - #10x0.875" LG. Screw, Quad.Pan Washer (E07-0077) x3</p>

INSTALL LEG(S) AND REINFORCEMENT CHANNEL

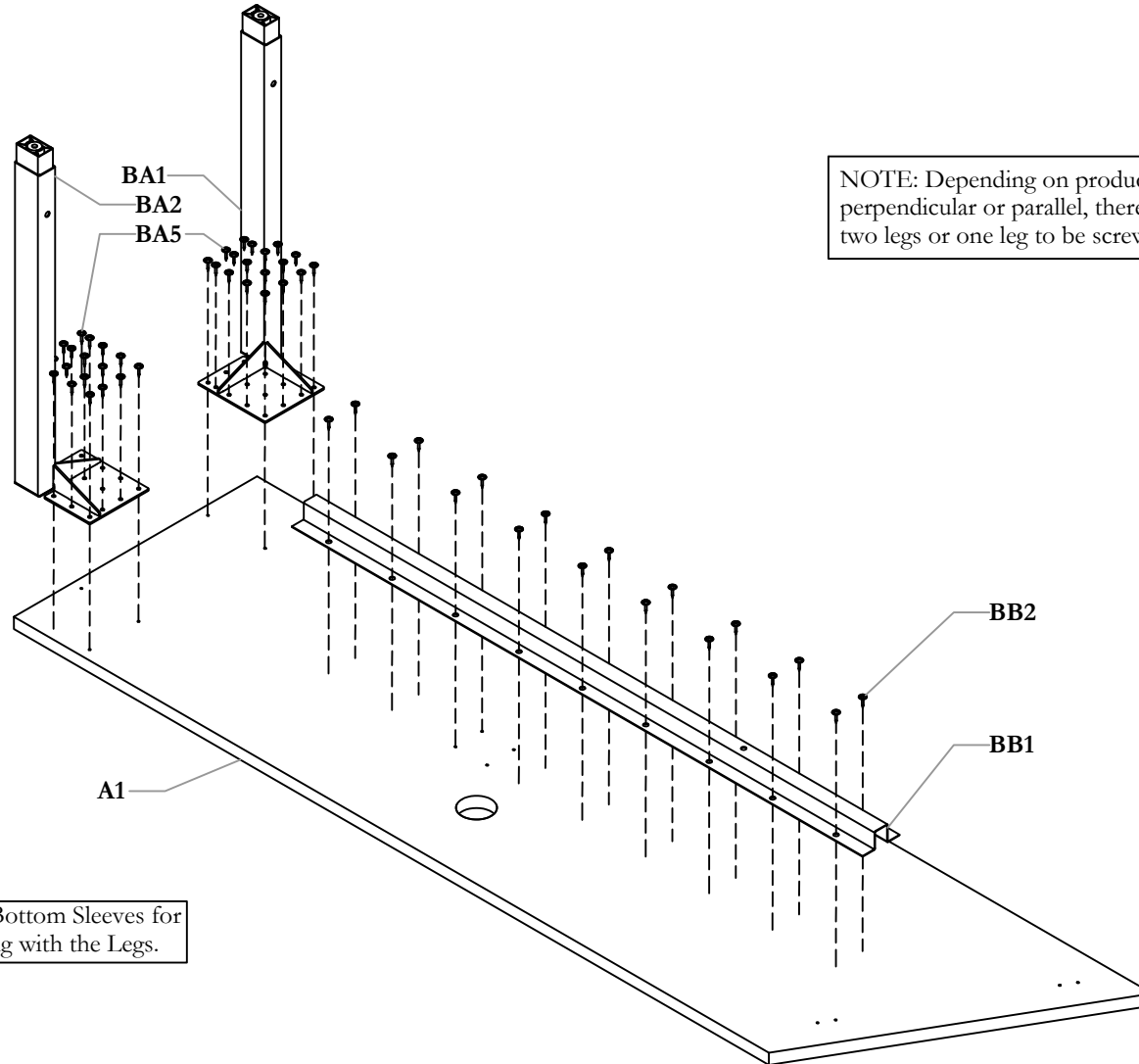

NOTE: Depending on product style perpendicular or parallel, there may be two legs or one leg to be screwed in.

NOTE: Ensure that the Bottom Sleeves for the Legs are installed along with the Legs.

STEP 1: Turn over Work Surface so that the pilot holes are facing up. Screw in the leg(s) and the Reinforcement Channel.

NOTE: Depending on product style perpendicular or parallel, there may be two legs or one leg to be screwed in.

NOTE: Ensure that the Bottom Sleeves for the Legs are installed along with the Legs.

Section: **WORKSURFACES & WORKSURFACE SUPPORTS**

Description: **120 ANGLED WORKSURFACE**

INSTALL BRACKETS ONTO POWER SPINE PANELS

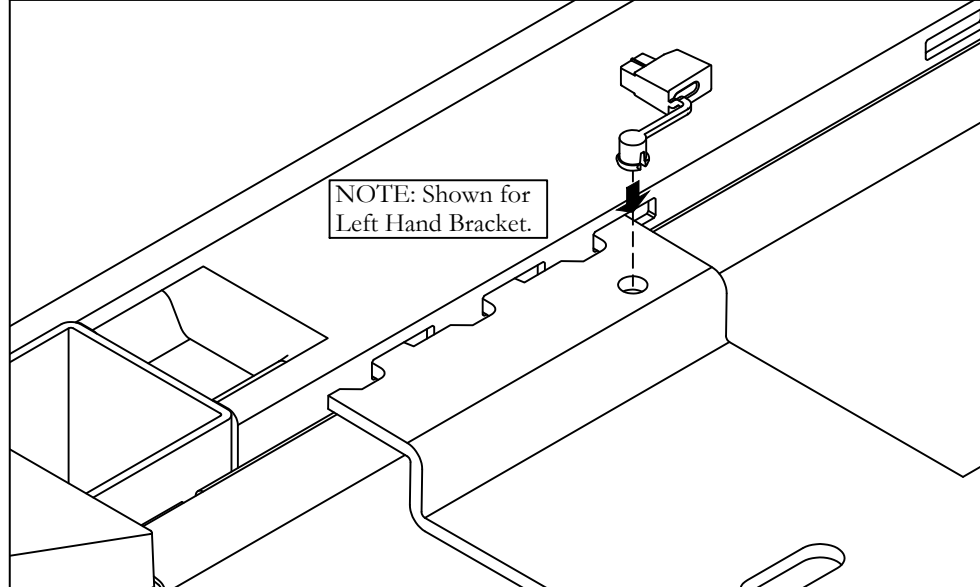
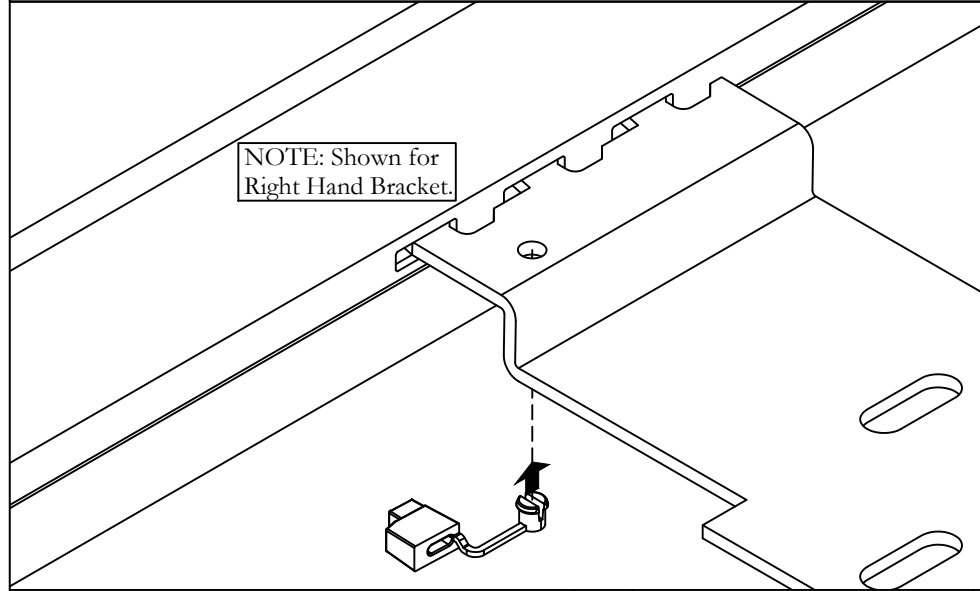

STEP 2b: Secure Bracket Retainer to the Bracket by inserting the circular part of the Retainer into the Bracket's hole.

NOTE: Shown for Right Hand Bracket.
NOTE: Shown for Left Hand Bracket.

INSTALL BRACKETS ONTO POWER SPINE PANELS

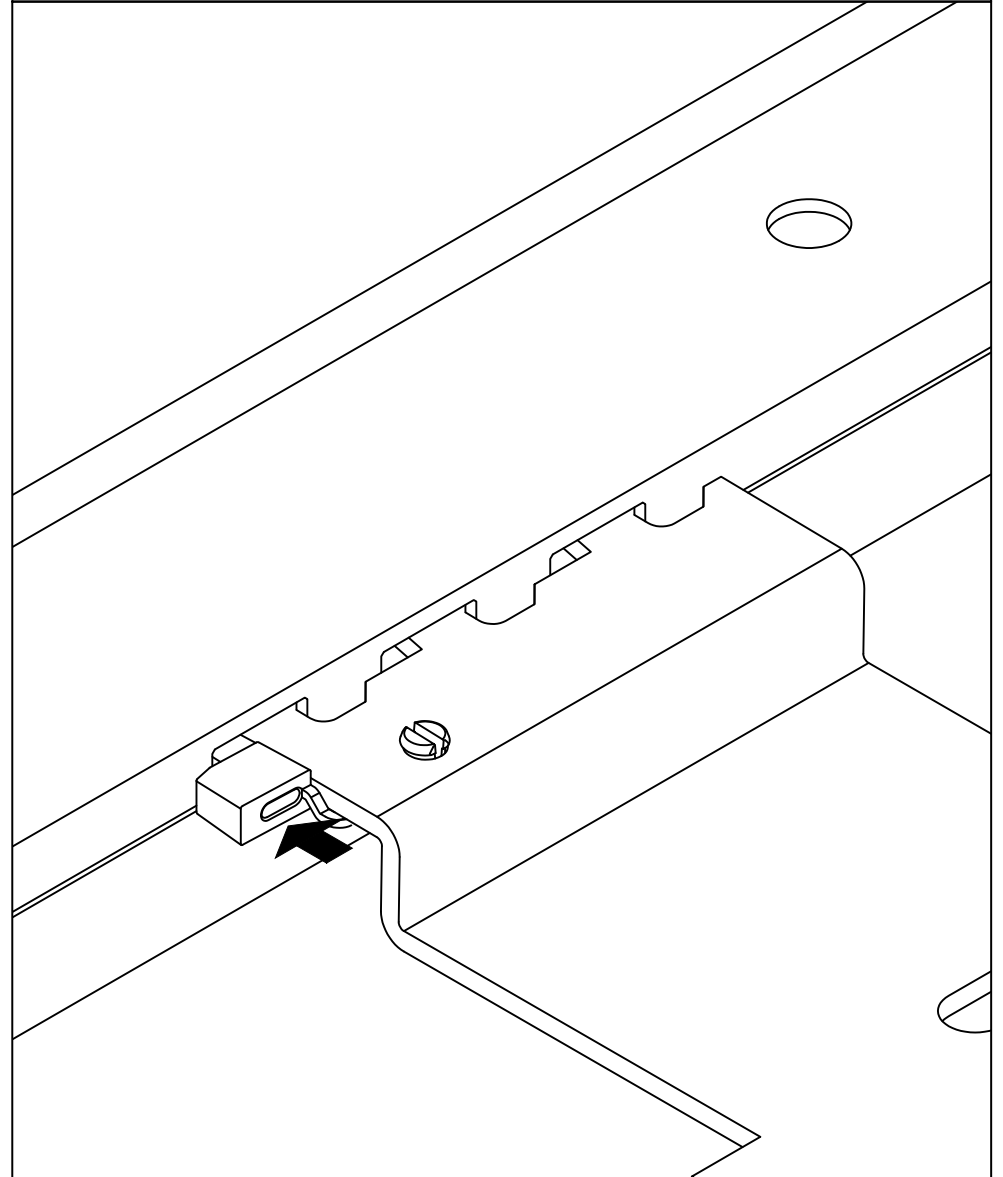

STEP 2c: Insert the Bracket Retainer in the gap that is left by the Bracket to secure the Bracket in place.

SECURE WORK SURFACE TO BRACKET

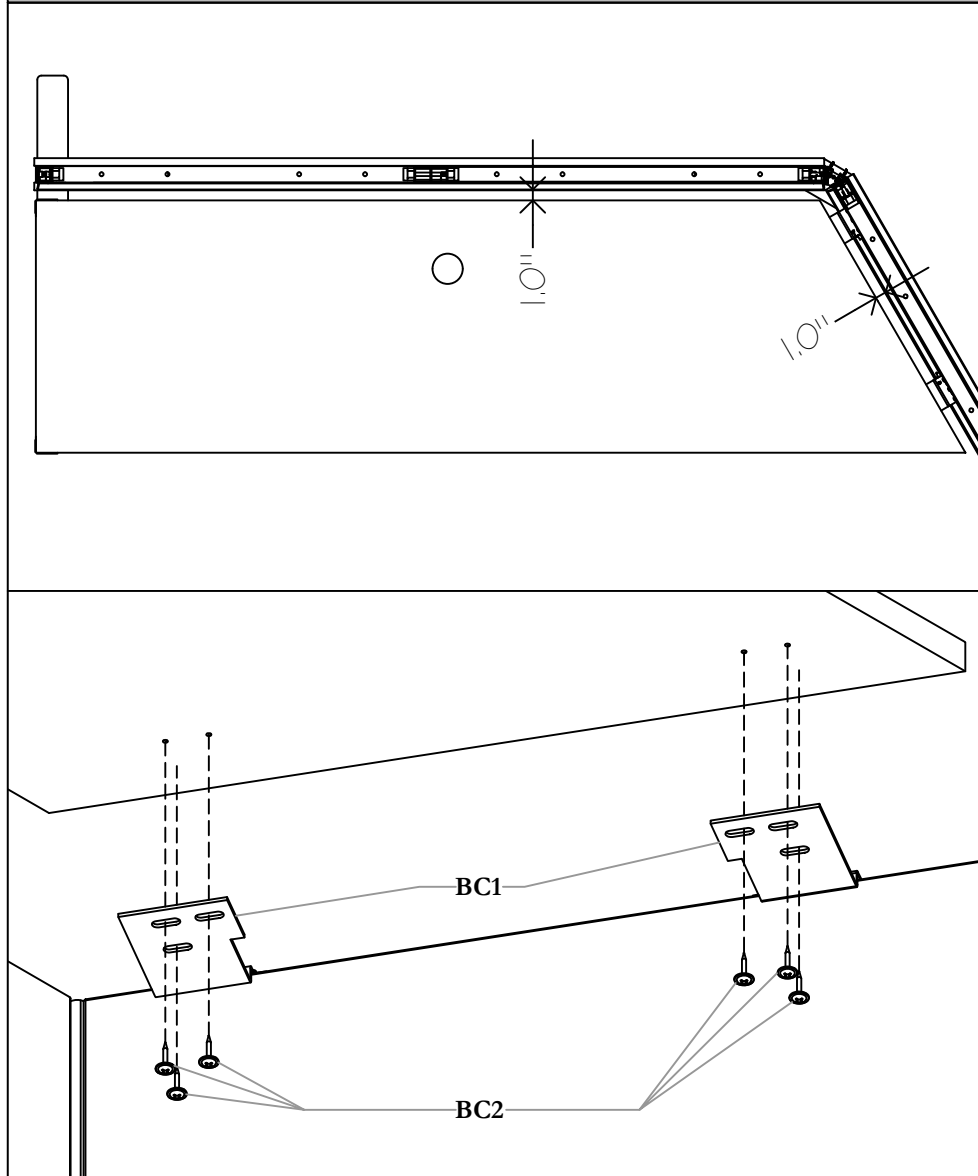

STEP 3a: Turn over the Work Surface so that it is right side up with legs facing the ground. Line up the pilot holes with the Bracket Screw Holes. Ensure a 1" gap between the Fascia and the Worksurface before securing the Work Surface to the Brackets.

SECURE 3RD BRACKET IF NEEDED

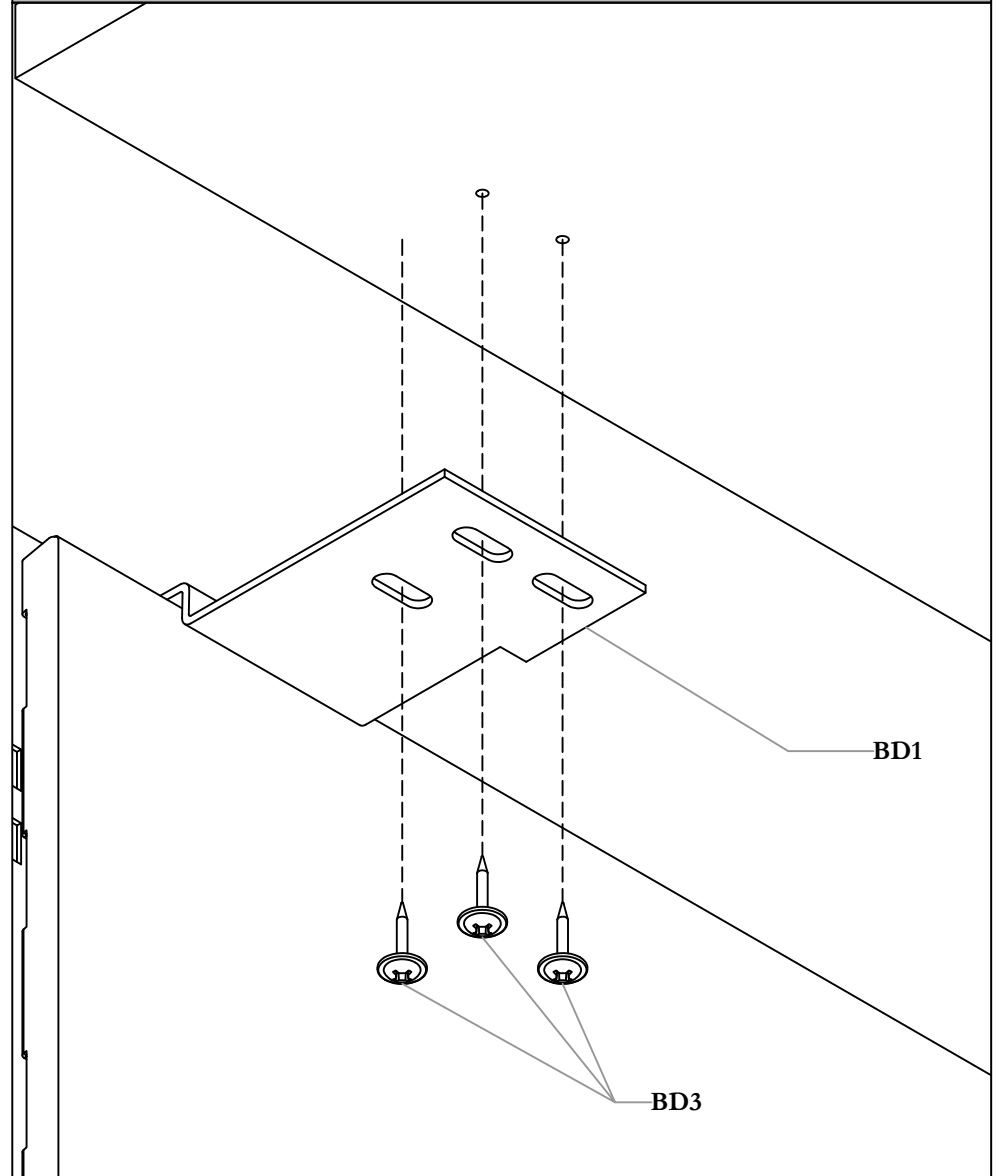

STEP 3b: If the product only has one leg, then X01-4060X will also need to be secured to the Worksurface.

Section: **WORKSURFACES & WORKSURFACE SUPPORTS**

Description: **120 ANGLED WORKSURFACE**

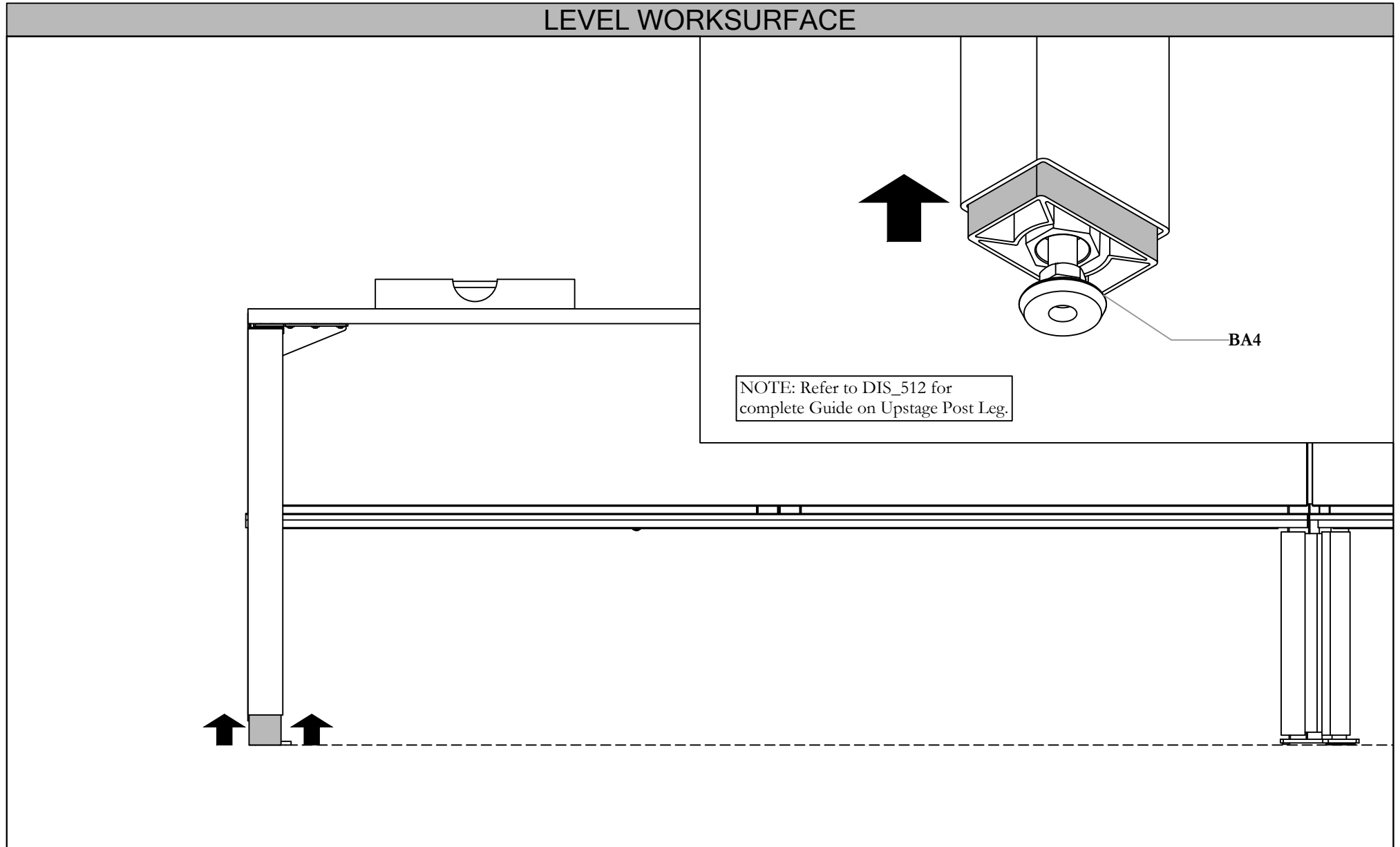

STEP 4: Level the Work Surface by lifting the bottom sleeve to reveal the Leg Leveler. The Leveler is a Right-Hand Thread, right spin to lower level and left spin to raise level.







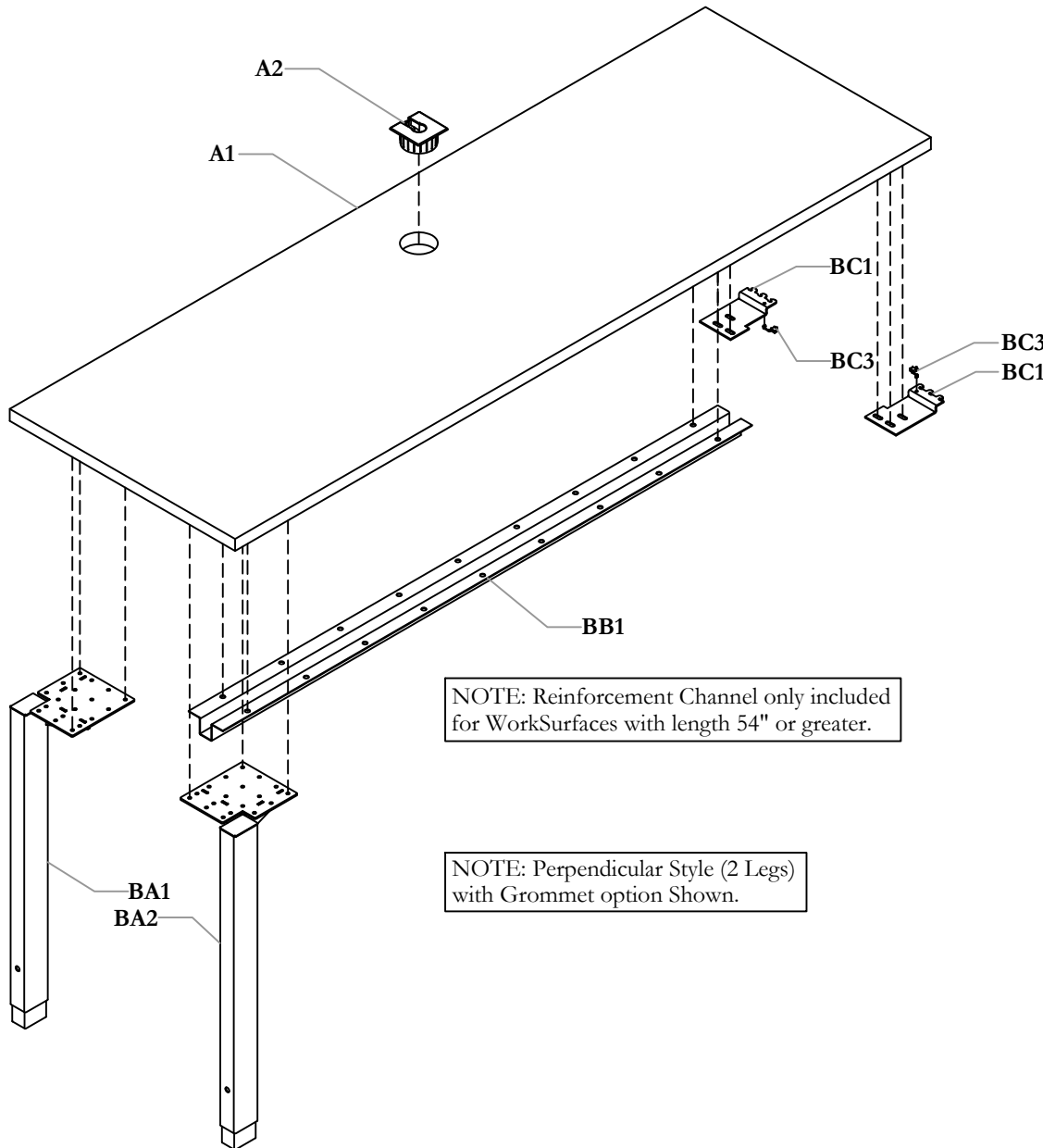

NOTE: Refer to DIS_512 for complete Guide on Upstage Post Leg.

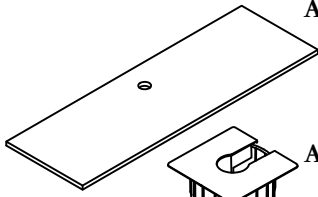
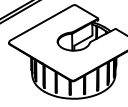
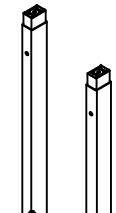
Section: **WORKSURFACES & WORKSURFACE SUPPORTS**
 Description: **POWER SPINE RECTANGLE WORKSURFACE**

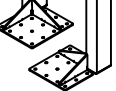
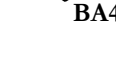
Power Spine Rectangle WorkSurface (UZWE), Rectangle WorkSurface Support Bundle (UZWC)

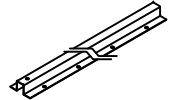

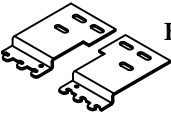
Part and Product Identification

A - UZWE	 A1 - Power Spine Rectangular WorkSurface (C07-8222X-X) x1  A2 - Square Grommet (YEDG2 (N09-1699)) xQty Varies
B - UZWC	 BA1 - Upstage Post Leg - Fix Height - Right (N09-5037R) xQty Varies (Comes Assembled)  BA2 - Upstage Post Leg - Fix Height - Left (N09-5037L) xQty Varies (Comes Assembled)  BA3 - Upstage Post Leg Cap Assembly (N09-5206) xQty Varies (Comes Assembled)  BA4 - Upstage Post Leg Leveler Subassembly (N09-5035) xQty Varies (Comes Assembled)  BA5 - #10x0.875" LG. Screw, Quad.Pan Washer (E07-0077) xQty Varies
BB - UNRC	 BB1 - Reinforcement Channel (A15-6956-X) xQty Varies  BB2 - #10x0.875" LG. Screw, Quad.Pan Washer (E07-0077) xQty Varies
BC - UNBP	 BC1 - Worksurface Panel Bracket - Pair (A15-6949L/R) x1  BC2 - #10x0.875" LG. Screw, Quad.Pan Washer (E07-0077) x6  BC3 - Bracket Retainer (B02-0242) x2

INSTALL LEGS AND REINFORCEMENT CHANNEL

NOTE: For Perpendicular Style Only.

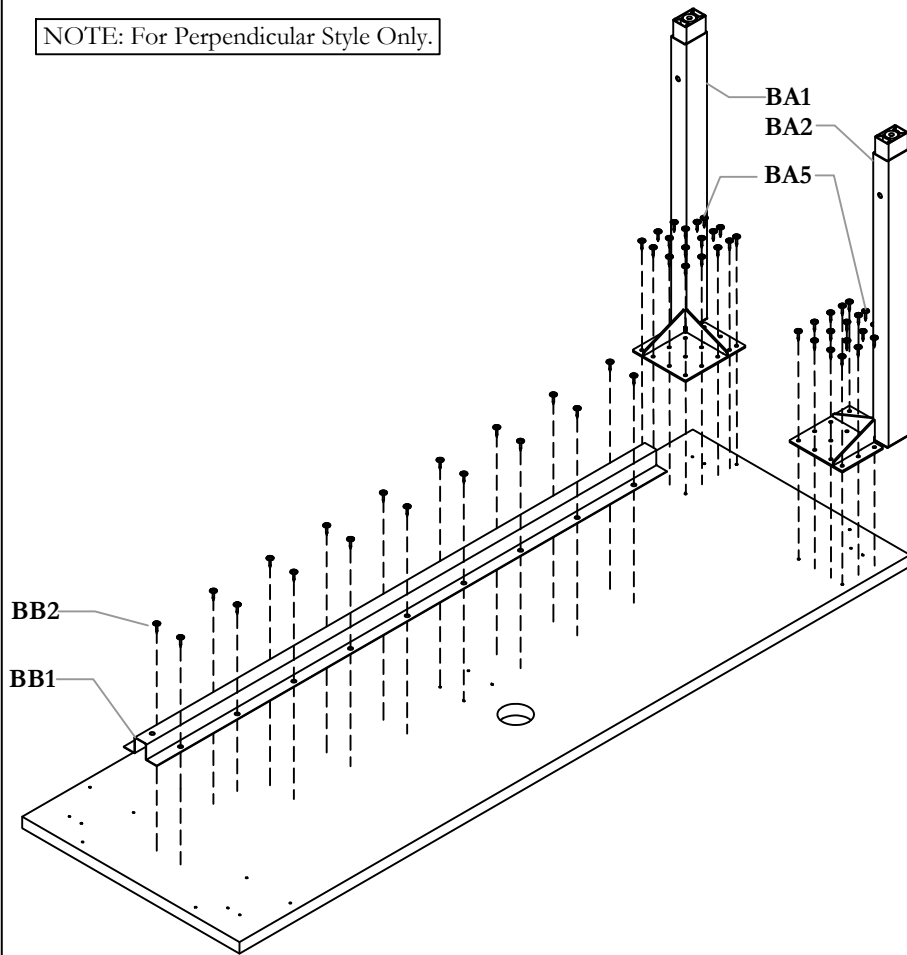

STEP 1a: Turn over Work Surface so that the pilot holes are facing up. Screw in the legs and the Reinforcement Channel.

NOTE: For Perpendicular Style Only.

INSTALL LEGS AND REINFORCEMENT CHANNEL

NOTE: For Freestanding Style Only.

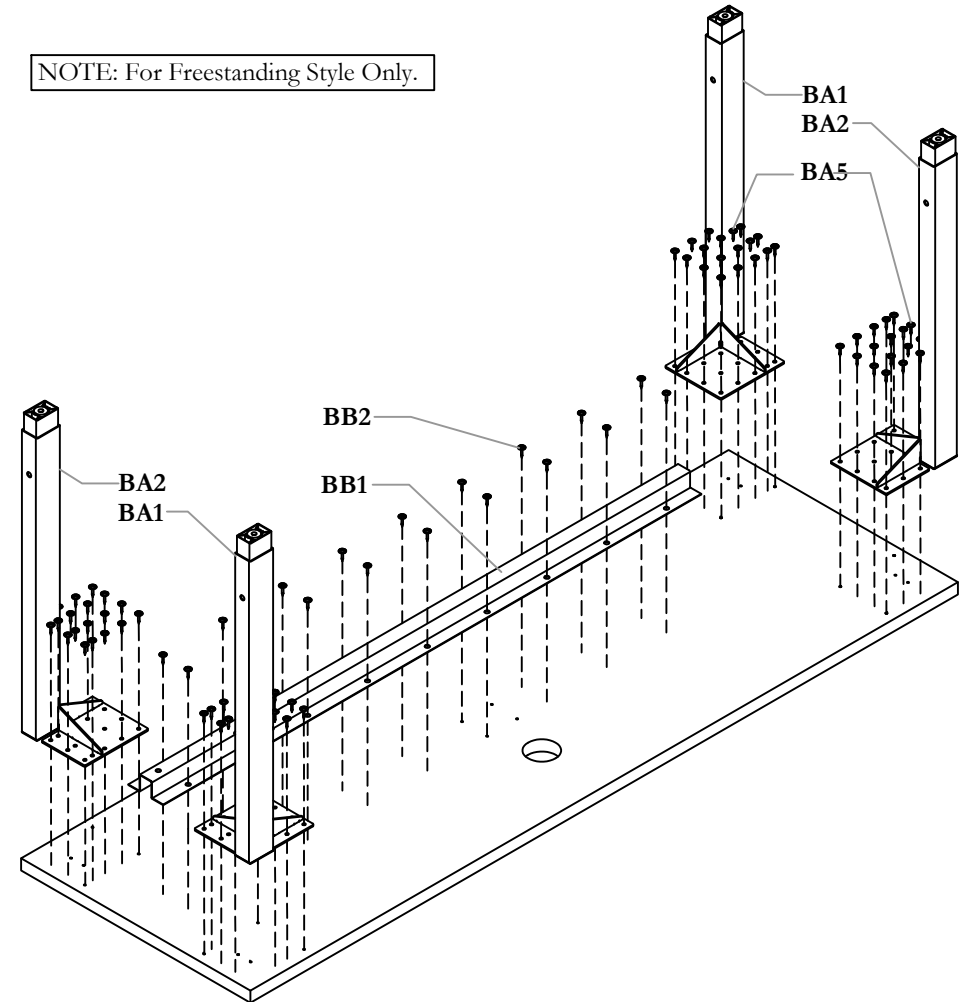

STEP 1b: Turn over Work Surface so that the pilot holes are facing up. Screw in the legs and the Reinforcement Channel.

NOTE: For Freestanding Style Only.

INSTALL BRACKETS

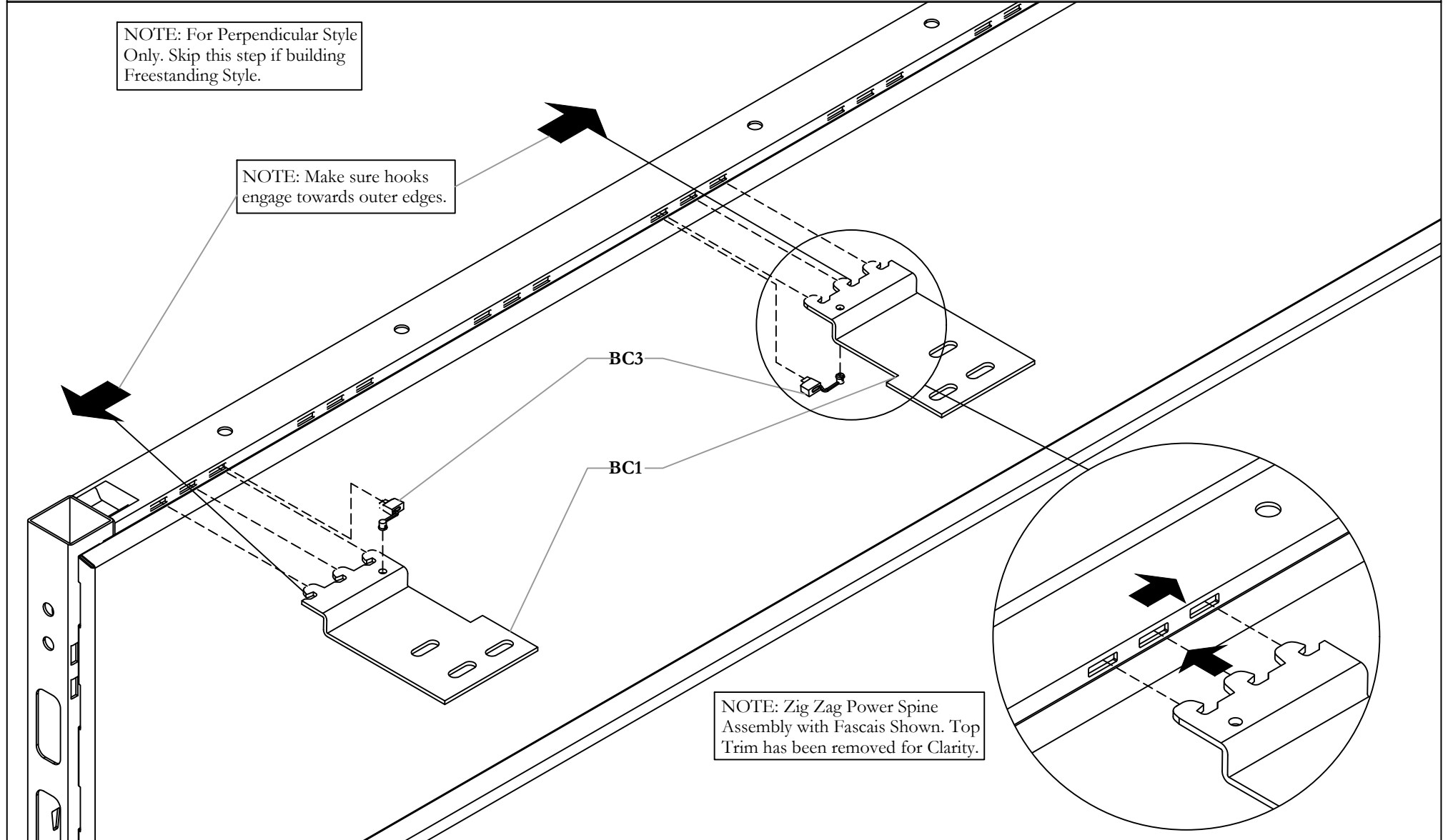

STEP 2a: Install Brackets onto the Power Spine Panels.

NOTE: For Perpendicular Style Only. Skip this step if building Freestanding Style.

NOTE: Make sure hooks engage towards the outer edges.

NOTE: Zig Zag Power Spine Assembly with Fascias Shown. Top Trim has been removed for Clarity.

Section: **WORKSURFACES & WORKSURFACE SUPPORTS**

Description: **POWER SPINE RECTANGLE WORKSURFACE**

INSTALL BRACKETS ONTO POWER SPINE PANEL

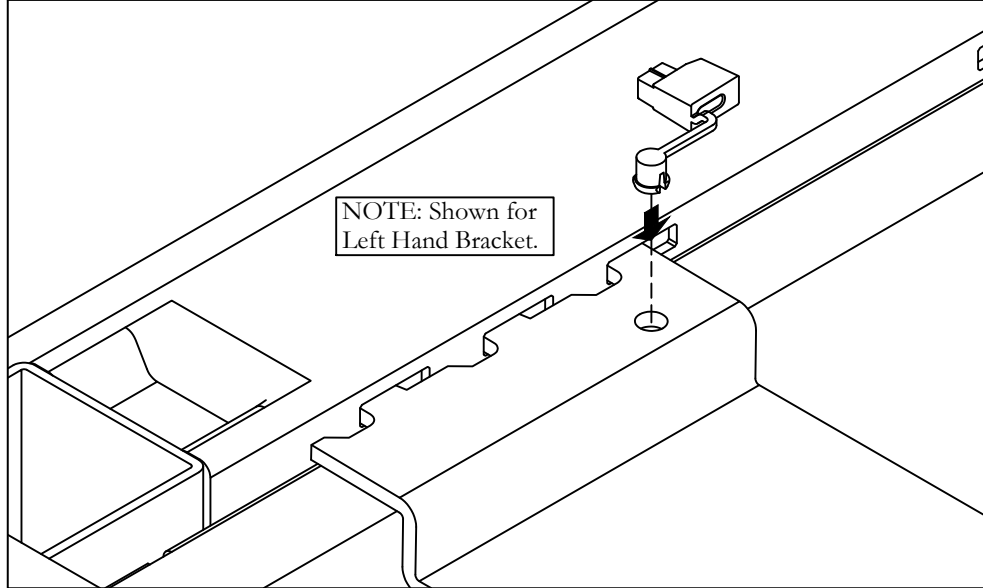
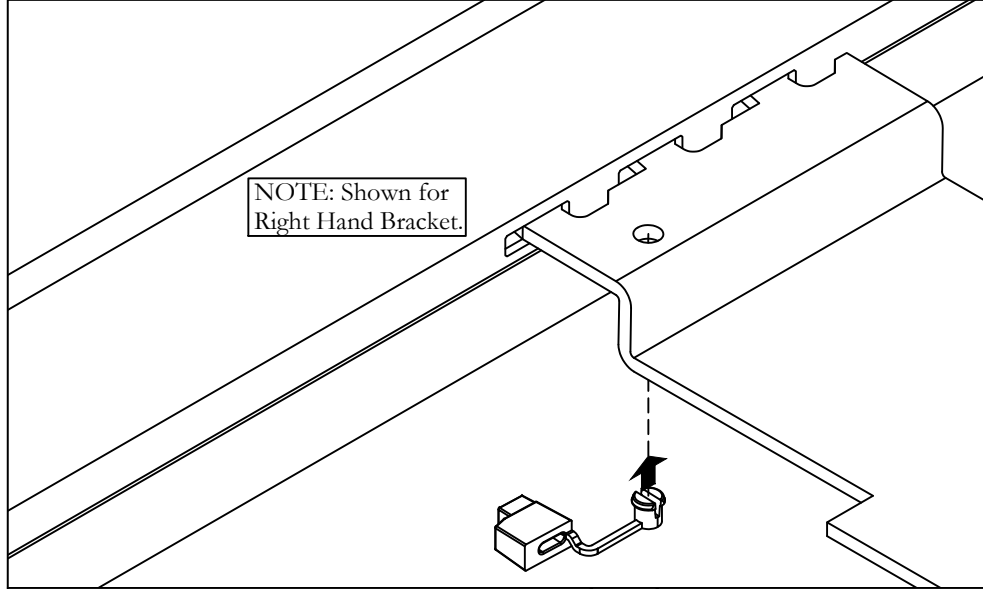

STEP 2b: Secure Bracket Retainer to the Bracket by inserting the circular part of the Retainer into the Bracket's hole.

NOTE: Shown for Right Hand Bracket.
NOTE: Shown for Left Hand Bracket.

INSTALL BRACKETS ONTO POWER SPINE PANEL

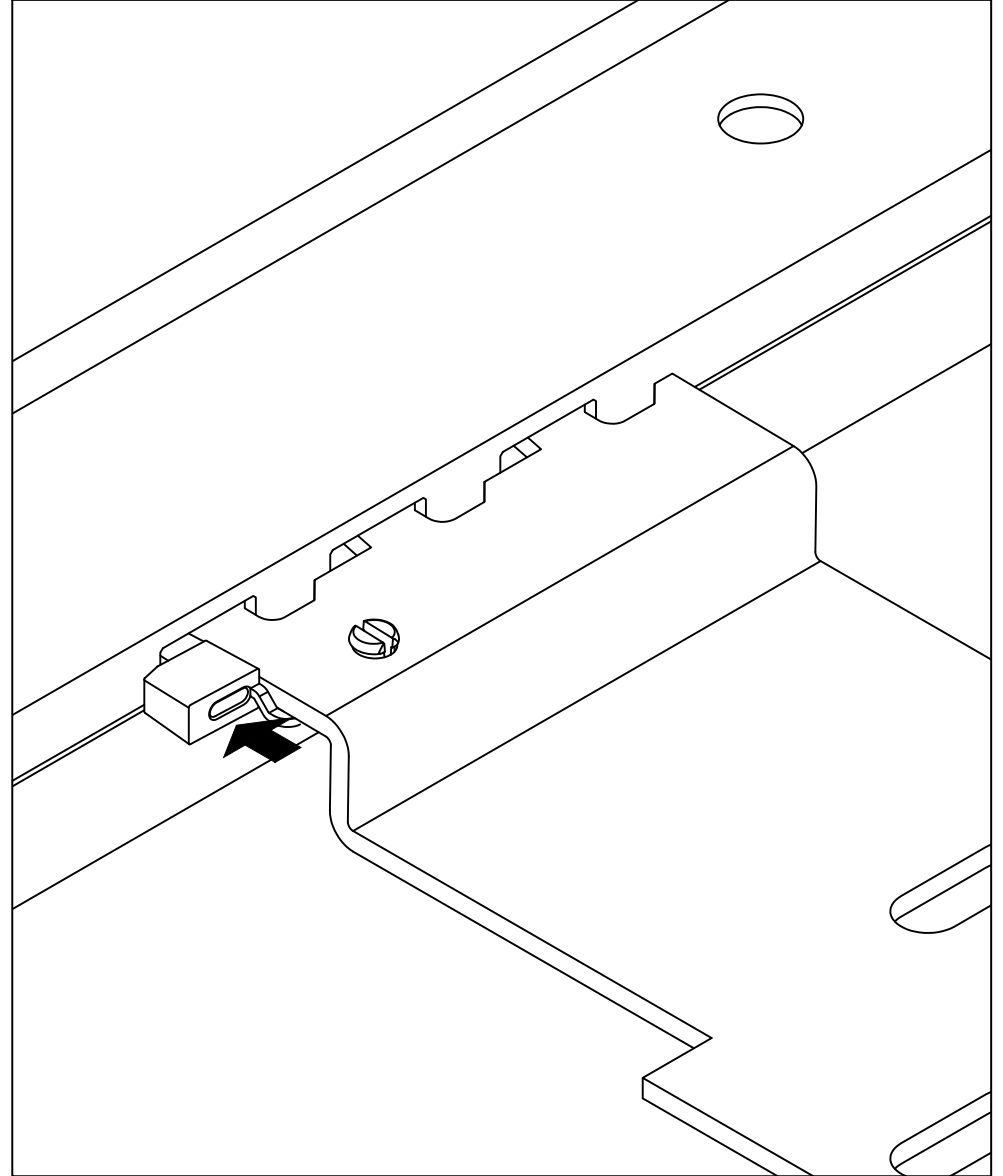

STEP 2c: Insert the Bracket Retainer in the gap that is left by the Bracket to secure the Bracket in place.

SECURE WORK SURFACE TO BRACKET

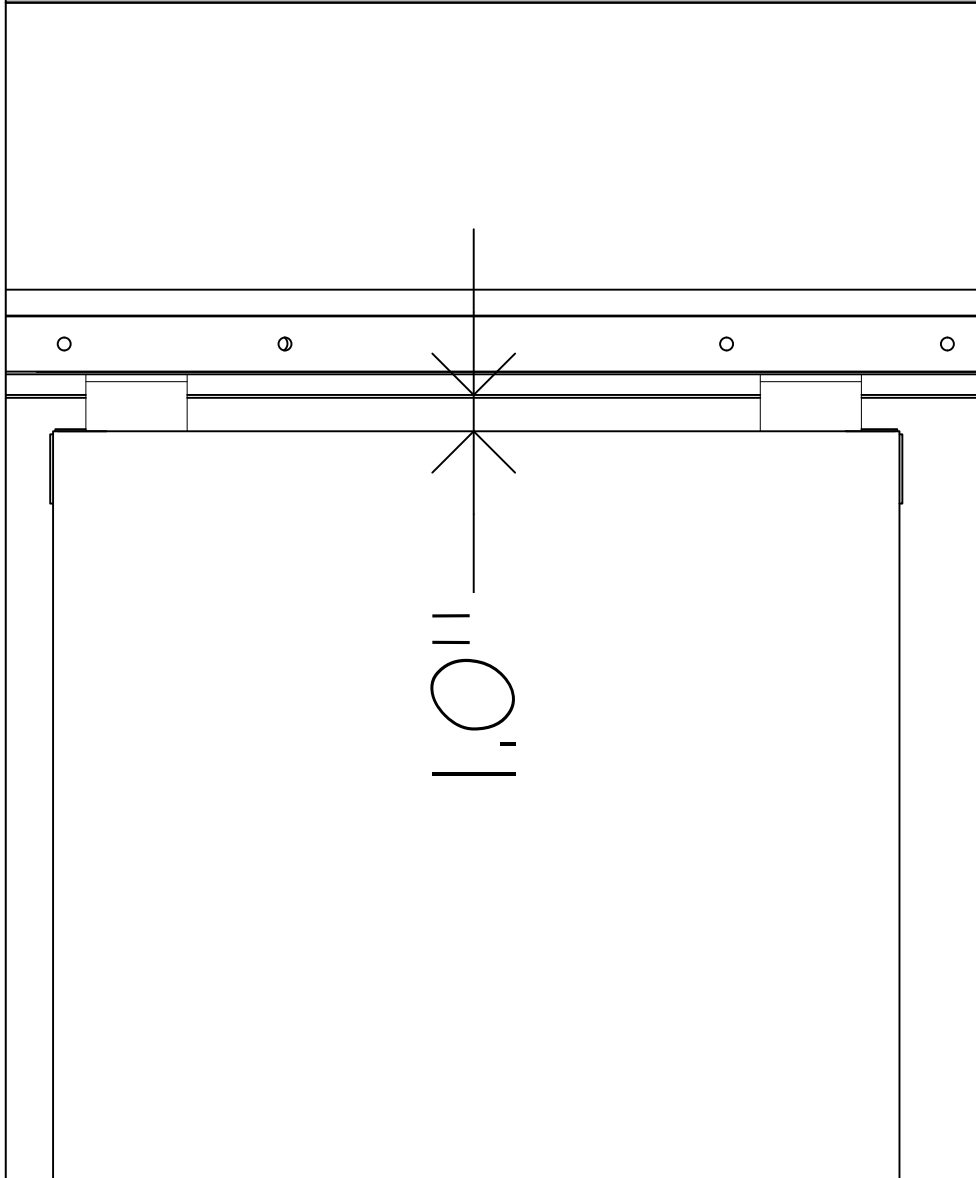

STEP 3a: Turn over the Work Surface so that it is right side up with legs facing the ground. Line up the pilot holes with the Bracket Screw Holes. Ensure a 1" gap between the Fascia and the Worksurface.

SECURE 3RD BRACKET IF NEEDED

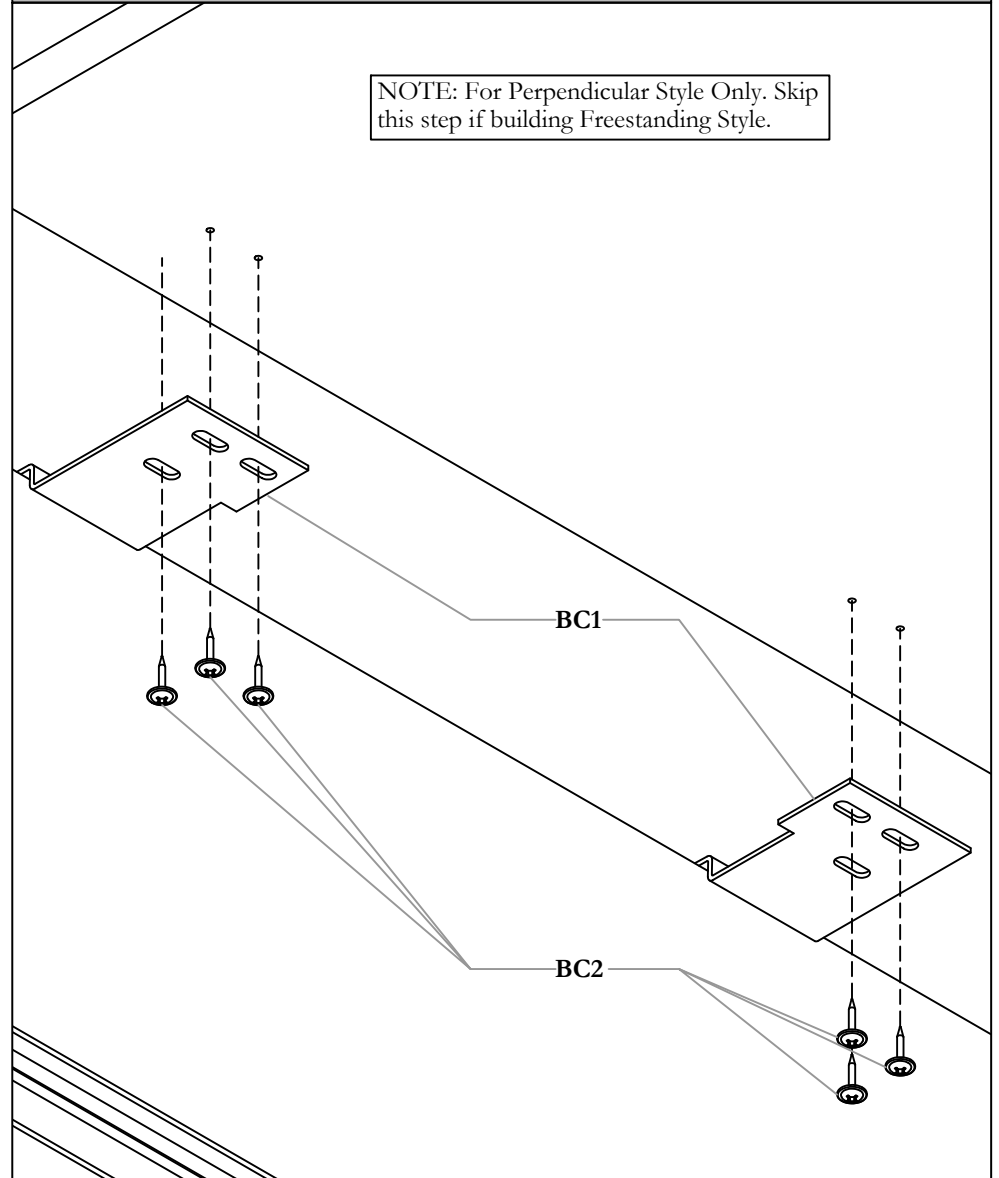

STEP 3b: Secure the Worksurface to the Brackets.

NOTE: For Perpendicular Style Only. Skip this step if building Freestanding Style.

Section: **WORKSURFACES & WORKSURFACE SUPPORTS**
Description: **POWER SPINE RECTANGLE WORKSURFACE**

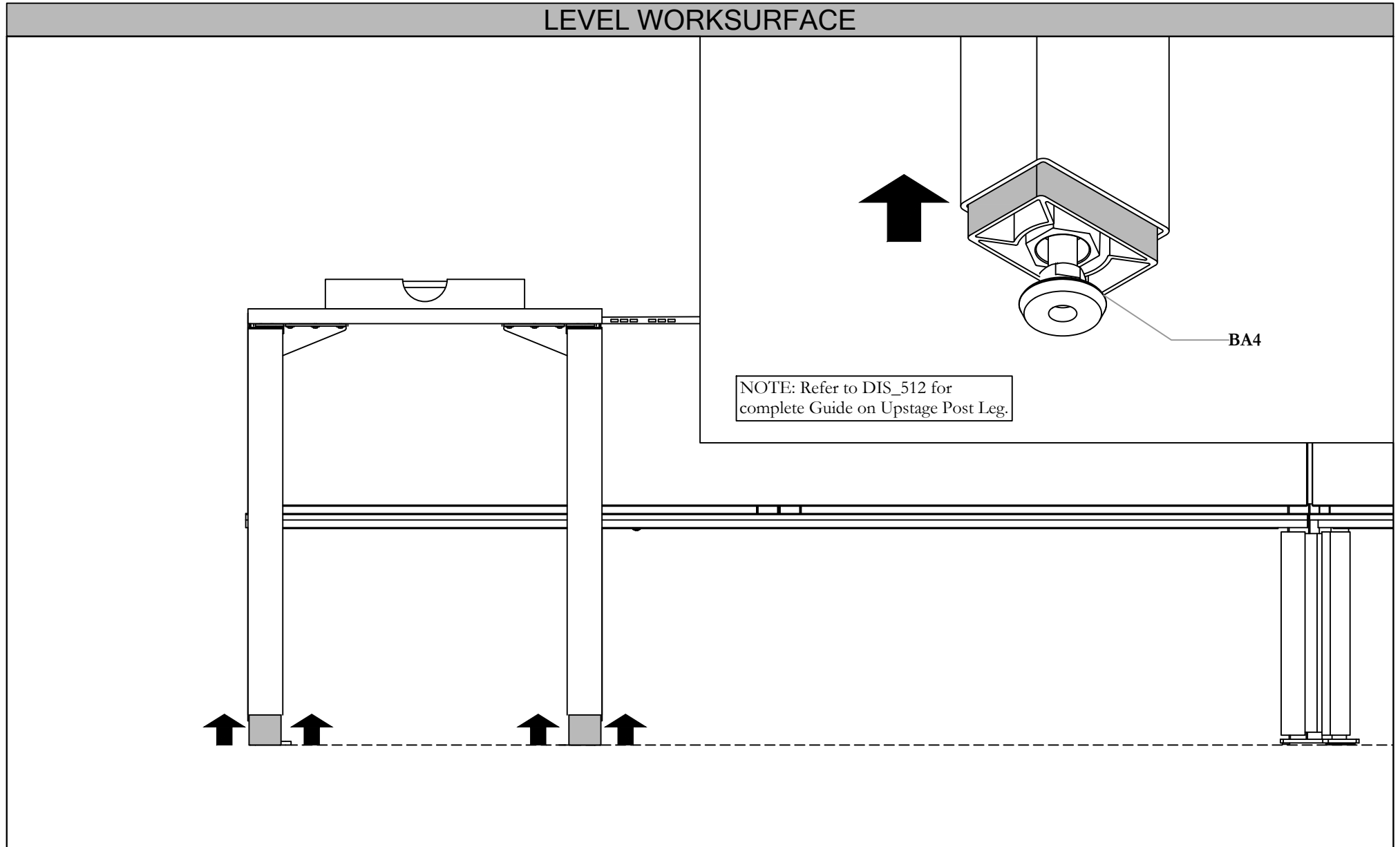

STEP 4: Level the Work Surface by lifting the bottom sleeve to reveal the Leg Leveler. The Leveler is a Right-Hand Thread, right spin to lower level and left spin to raise level.

NOTE: Refer to DIS_512 for complete Guide on Upstage Post Leg.

Parallelogram Worksurface (UZWP), Parallelogram Worksurface Support Bundle (UZWK)

NOTE: Reinforcement Channel only included for WorkSurfaces with length 66" or greater.

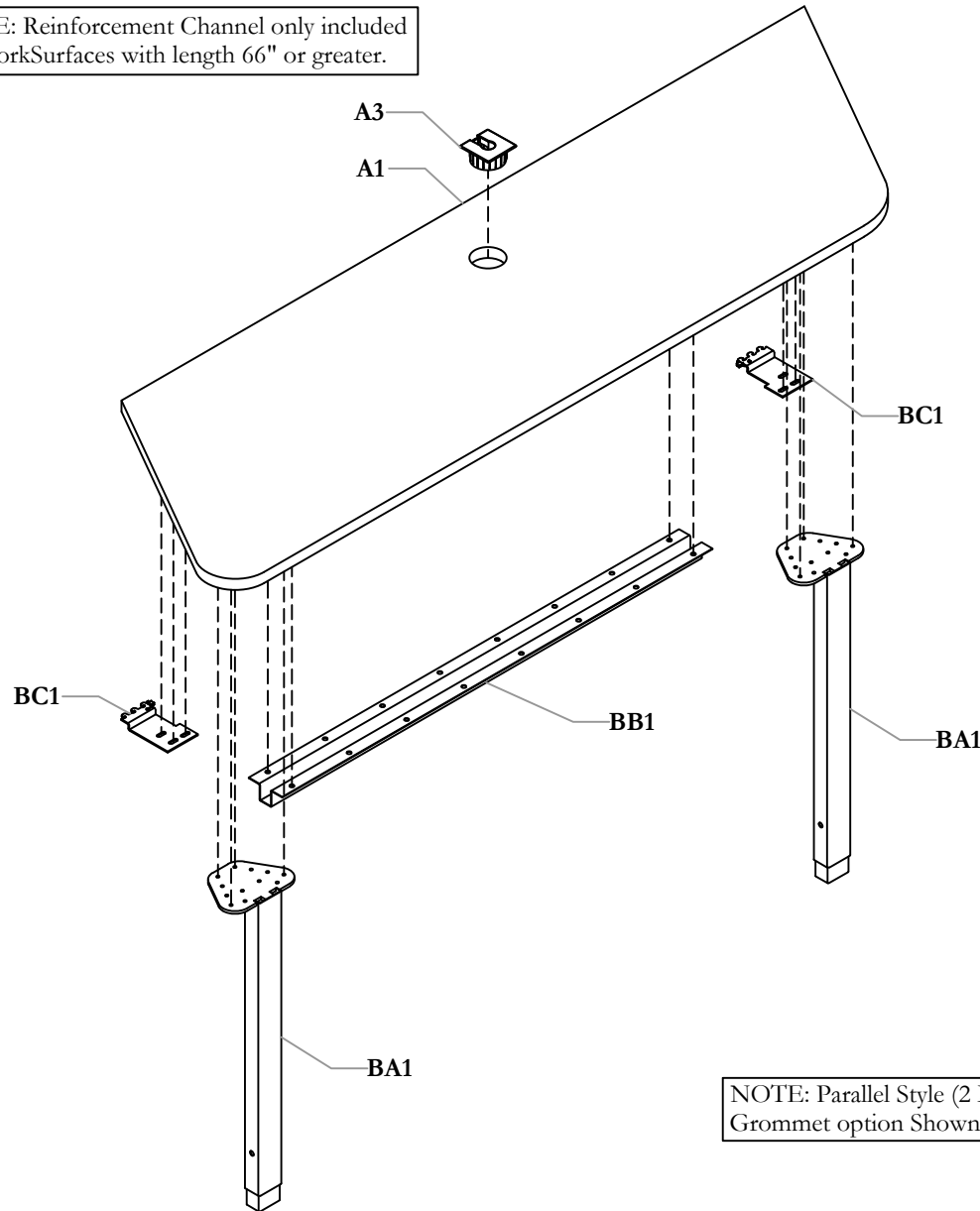

NOTE: Parallel Style (2 Legs) with Grommet option Shown.

Part and Product Identification

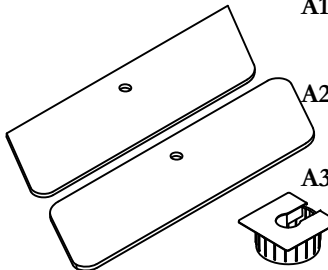
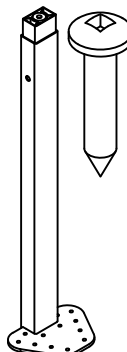
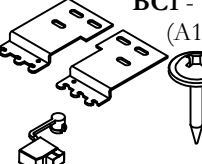
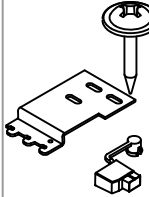
A - UZWP	 <p>A1 - Power Spine Parallelogram Worksurface - Parallel (C07-8117X-X) x1 OR A2 - Power Spine Parallelogram Worksurface - Freestanding (C07-8115X-X) x1 A3 - Square Grommet (YEDG2 (N09-1699)) xQty Varies</p>
BA - 120 Power Spine Leg Assembly (N01-6024-X)	 <p>BA1 - 120 Power Spine Leg Weldment (N01-6025-X) x Qty Varies (Comes Assembled) BA2 - Leveler Lock Nut (A25-0424) xQty Varies (Comes Assembled) BA3 - Leveler Cover (A23-4372/03) xQty Varies (Comes Assembled) BA4 - Tilting Benching Leveler (D05-0058) xQty Varies (Comes Assembled) BA5 - #10x1" Pan Quadrex Wood Screw, Deep Thread, Zink (E07-0097) xQty Varies</p>
B - UZWK	<p>BB1 - Reinforcement Channel (A15-6956-X) xQty Varies BB2 - #10x0.875" LG. Screw, Quad.Pan Washer (E07-0077) xQty Varies</p>
BC - UNBP	 <p>BC1 - Worksurface Panel Bracket - Pair (A15-6949L/R) x1 BC2 - #10x0.875" LG. Screw, Quad.Pan Washer (E07-0077) x6 BC3 - Bracket Retainer (B02-0242) x2</p>
BD - Worksurface Panel Bracket Kit (X01-4060L/R) xQty Varies	 <p>BD1 - Worksurface Panel Bracket (A15-6949L or R) x1 BD2 - Bracket Retainer (B02-0242) x1 BD3 - #10x0.875" LG. Screw, Quad.Pan Washer (E07-0077) x3</p>

INSTALL LEG(S) AND REINFORCEMENT CHANNEL

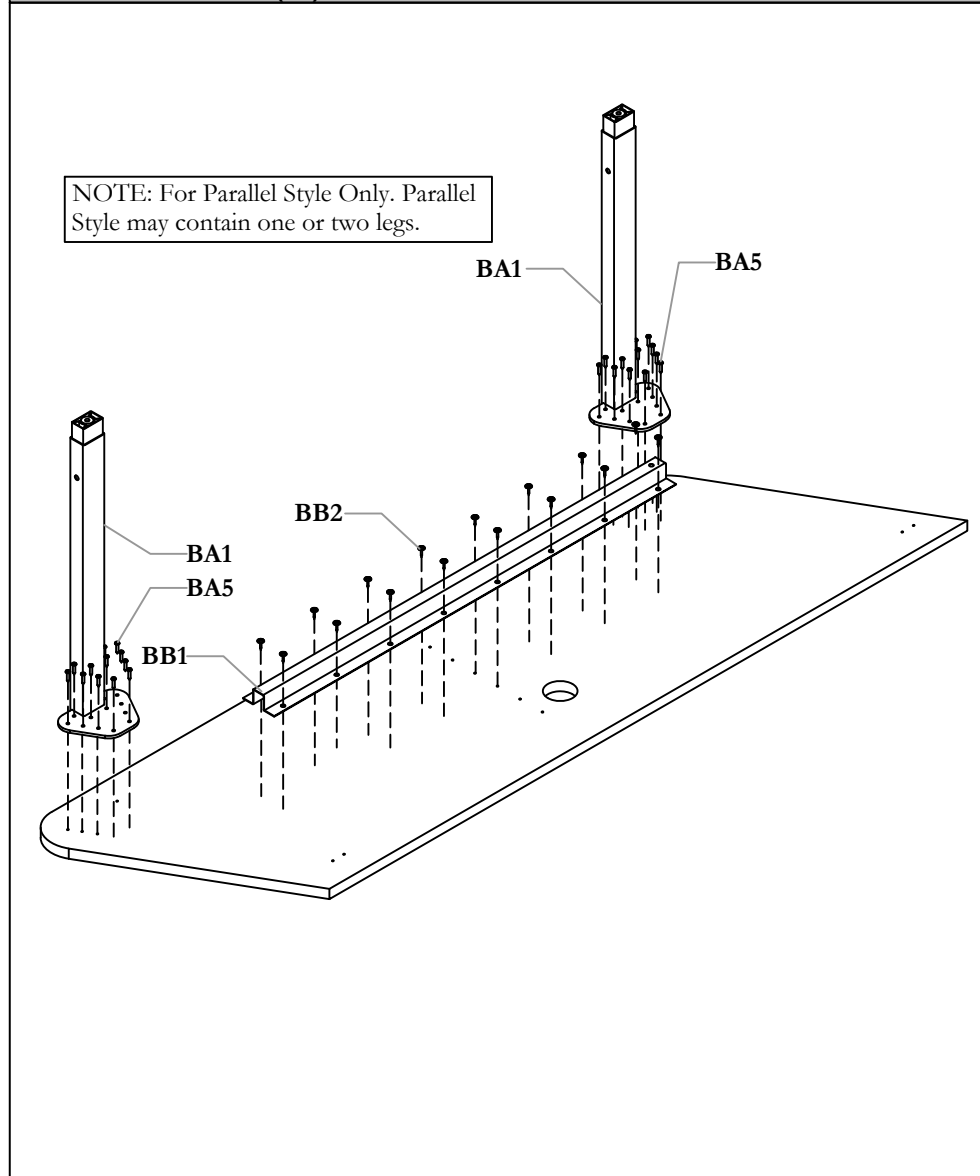

STEP 1a: Turn over Work Surface so that the pilot holes are facing up. Screw in the leg(s) and the Reinforcement Channel.

NOTE: For Parallel Style Only. Parallel Style may contain one or two legs.

INSTALL LEGS AND REINFORCEMENT CHANNEL

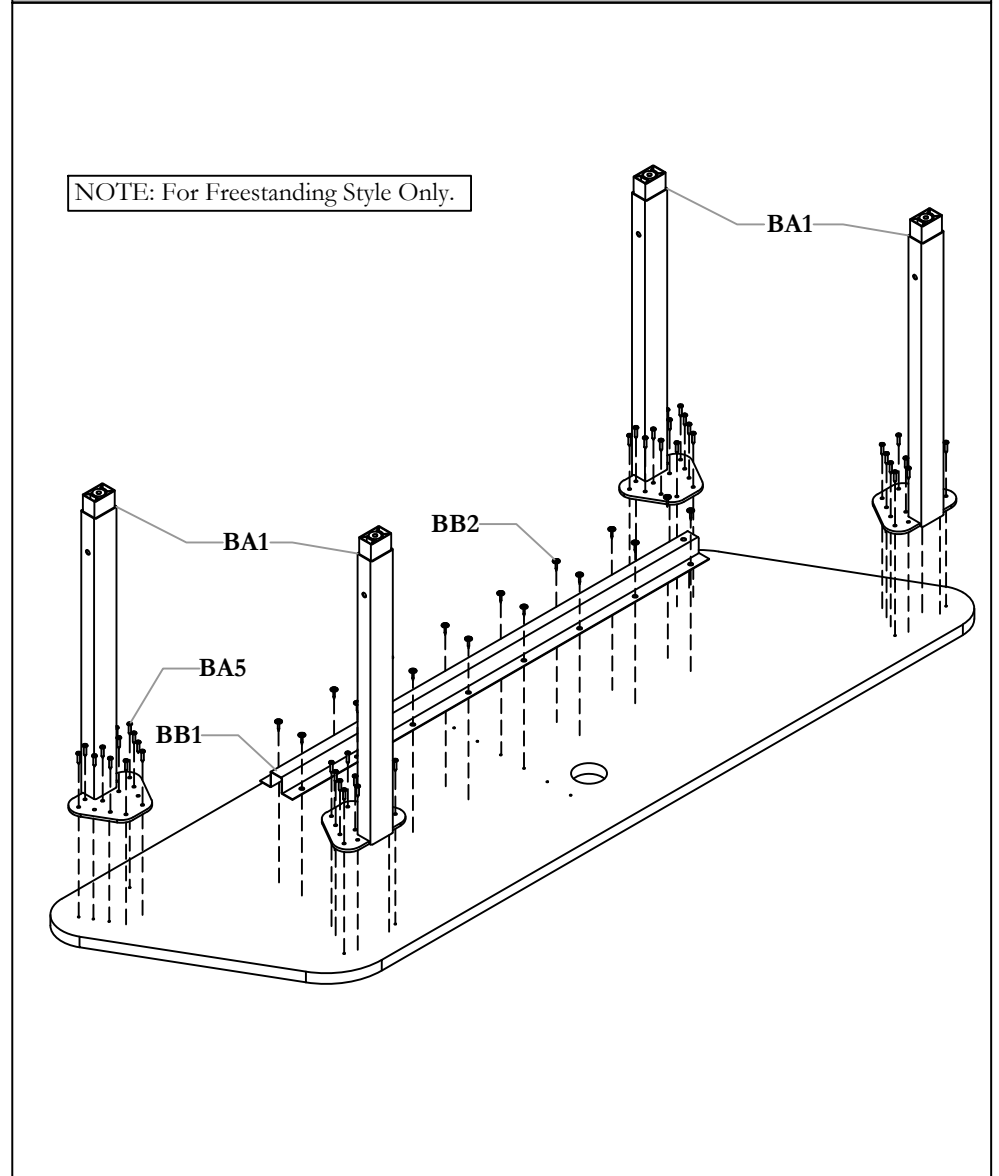

STEP 1b: Turn over Work Surface so that the pilot holes are facing up. Screw in the legs and the Reinforcement Channel.

NOTE: For Freestanding Style Only.

INSTALL BRACKETS

NOTE: For Parallel Style Only. Skip this Step if building Freestanding.

NOTE: If there are two legs, there are only two Brackets to install. If there is only one leg, then install X01-4060X located opposite to the leg.

NOTE: Make sure hooks engage towards the outer edges.

NOTE: Zig Zag Power Spine Assembly with Fascias Shown. Top Trim has been removed for Clarity.

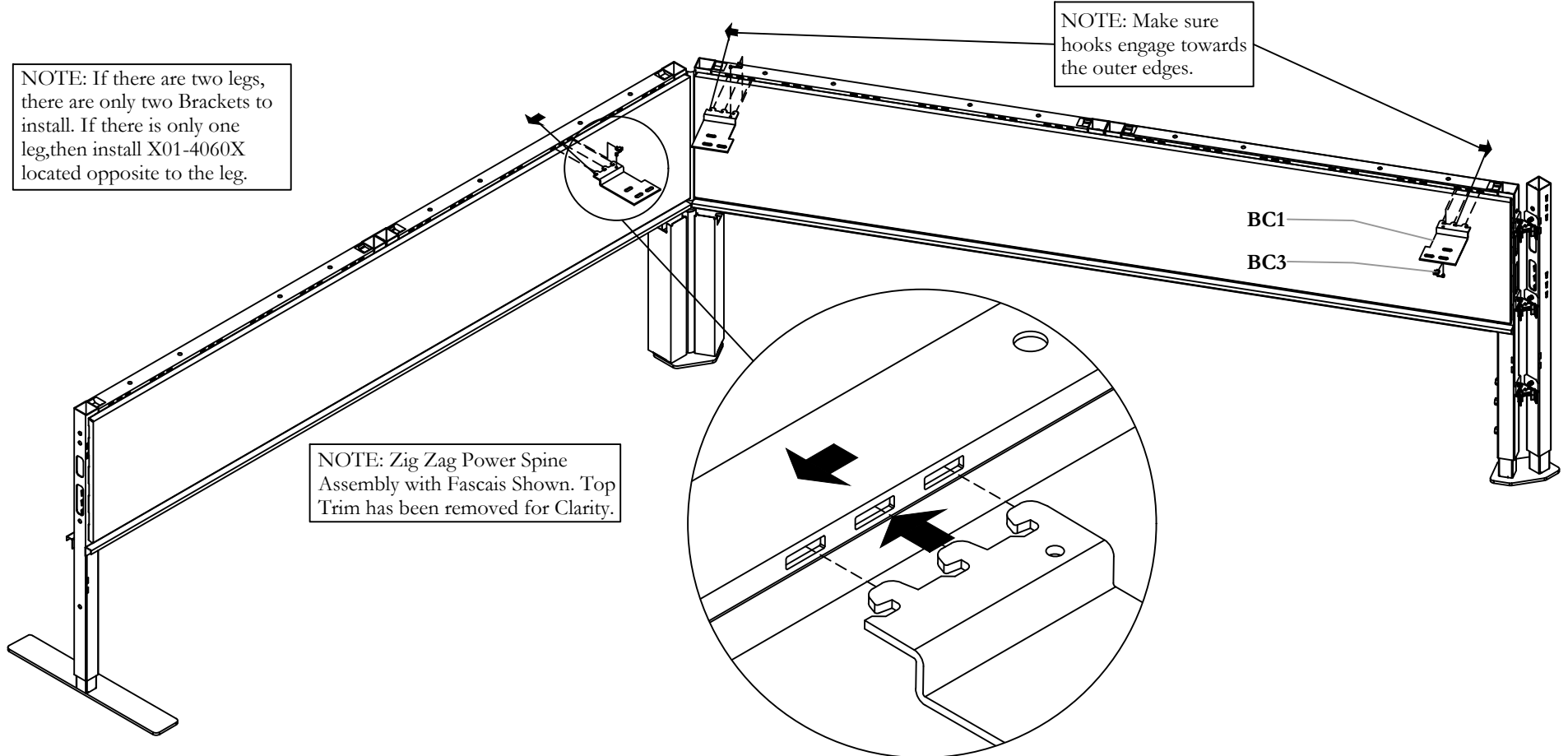

STEP 2a: Install Brackets onto the Power Spine Panels.

NOTE: For Parallel Style Only. Skip this Step if building Freestanding.

NOTE: Make sure hooks engage towards the outer edges.

NOTE: If there are two legs, there is only one Bracket Pair to install. If there is only one leg, then install X01-4060X located opposite to the leg.

NOTE: Zig Zag Power Spine Assembly with Fascias Shown. Top Trim has been removed for Clarity.

INSTALL BRACKETS ONTO POWER SPINE PANELS

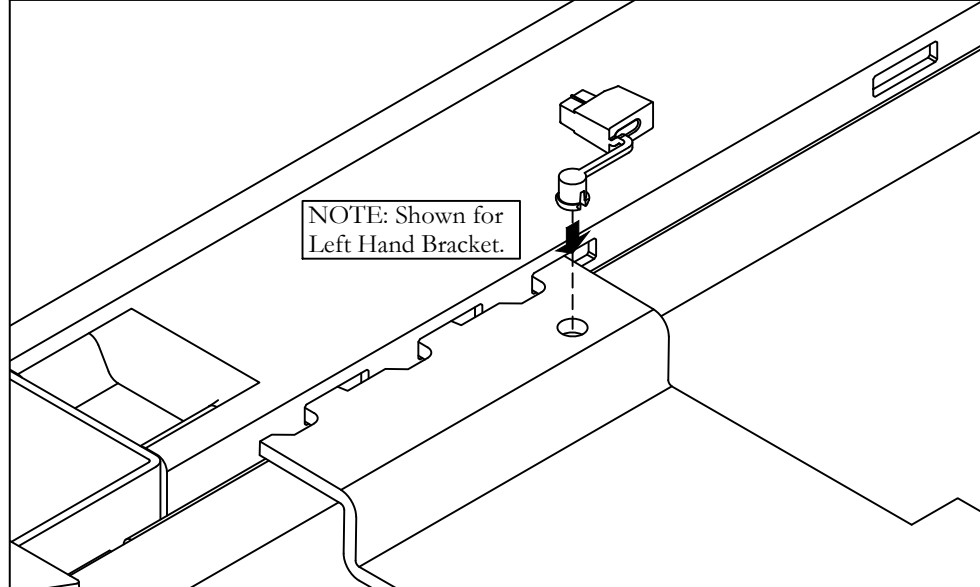
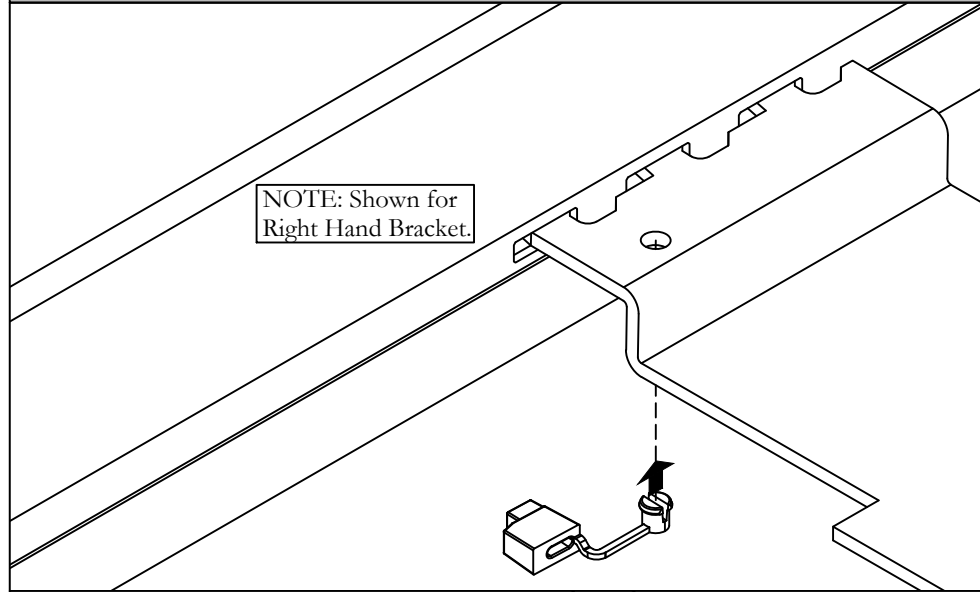

STEP 2b: Secure Bracket Retainer to the Bracket by inserting the circular part of the Retainer into the Bracket's hole.

NOTE: Shown for Right Hand Bracket.
NOTE: Shown for Left Hand Bracket.

INSTALL BRACKETS ONTO POWER SPINE PANELS

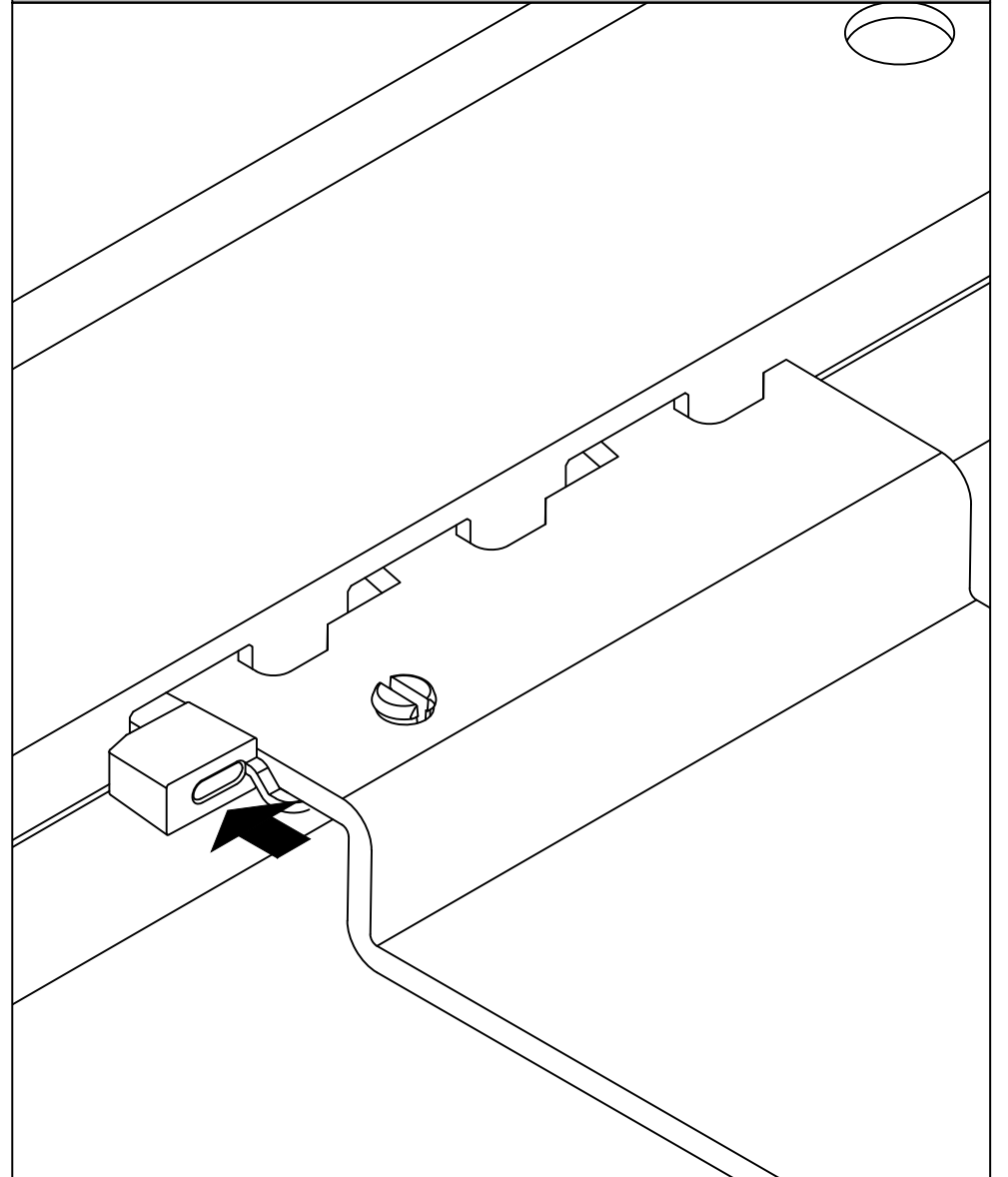

STEP 2c: Insert the Bracket Retainer in the gap that is left by the Bracket to secure the Bracket in place.

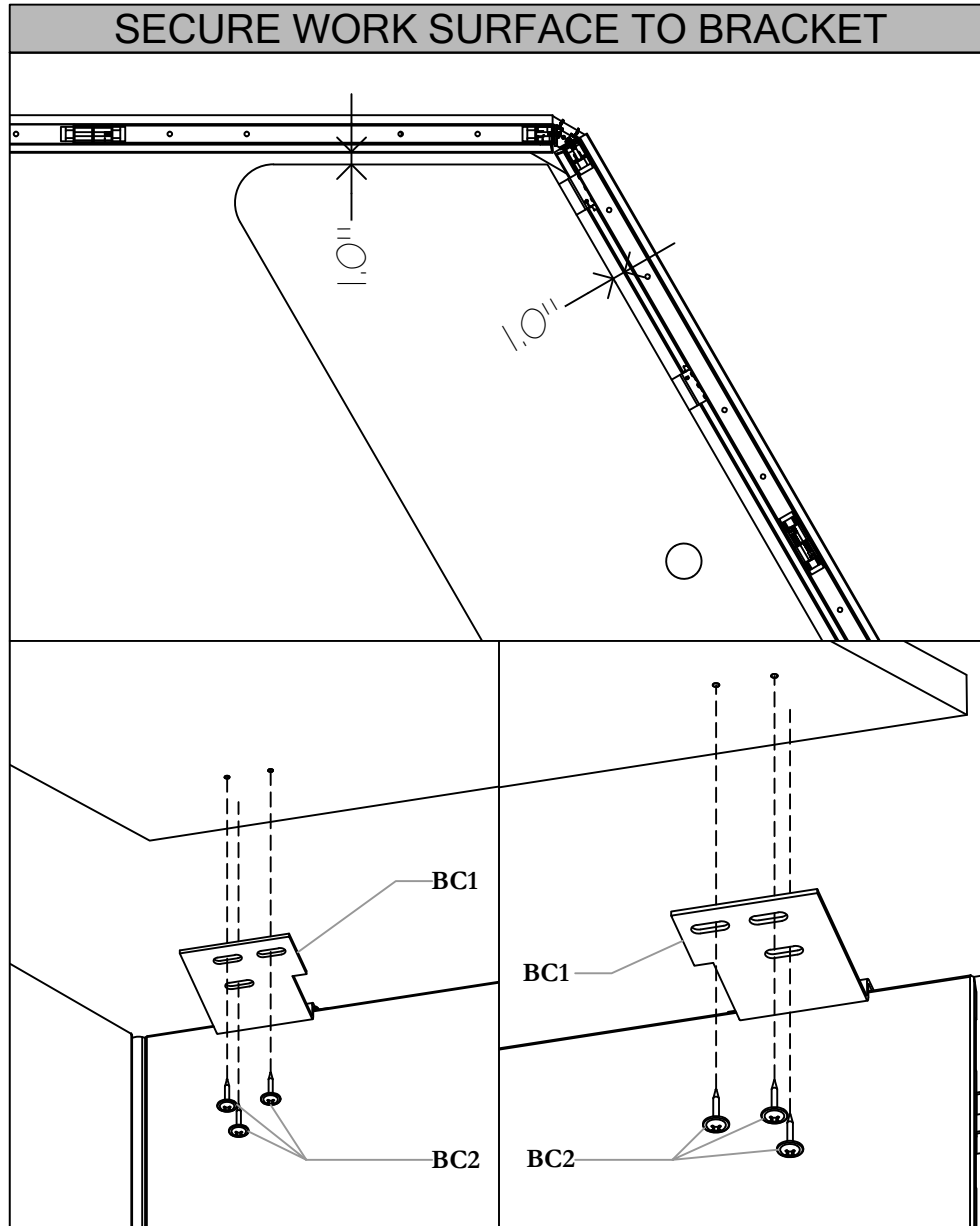

STEP 3a: Turn over the Work Surface so that it is right side up with legs facing the ground. Line up the pilot holes with the Bracket Screw Holes. Ensure a 1" gap between the Fascia and the Worksurface before securing the Work Surface to the Brackets.

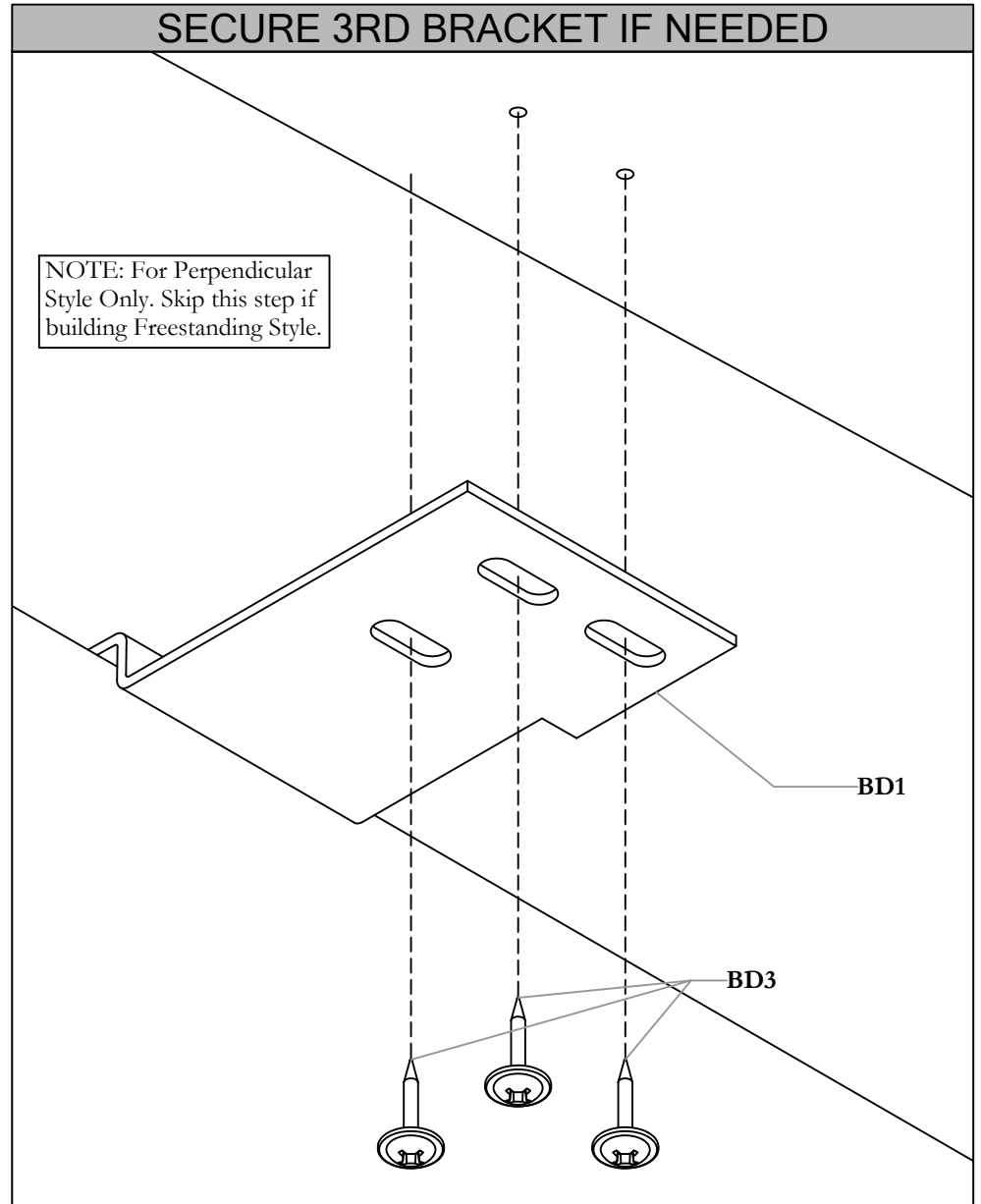

STEP 3b: If the product only has one leg, then X01-4060X will also need to be secured to the Worksurface.

NOTE: For Perpendicular Style Only. Skip this step if building Freestanding Style.

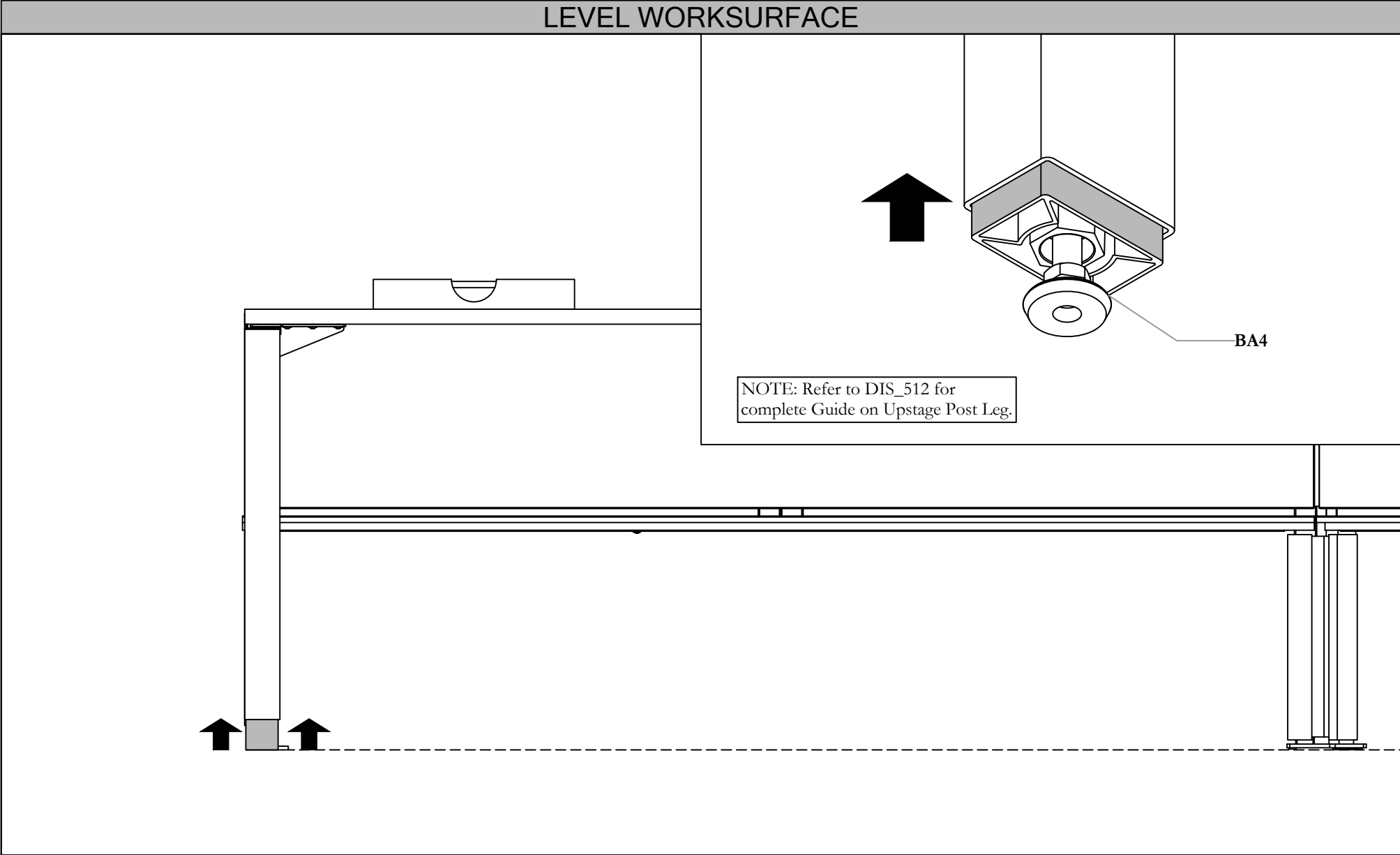

STEP 4: Level the Work Surface by lifting the bottom sleeve to reveal the Leg Leveler. The Leveler is a Right-Hand Thread, right spin to lower level and left spin to raise level.

NOTE: Refer to DIS_512 for complete Guide on Upstage Post Leg.

120 Hub WorkSurface (UZWT), 120 Hub WorkSurface Support Bundle (UZWW)

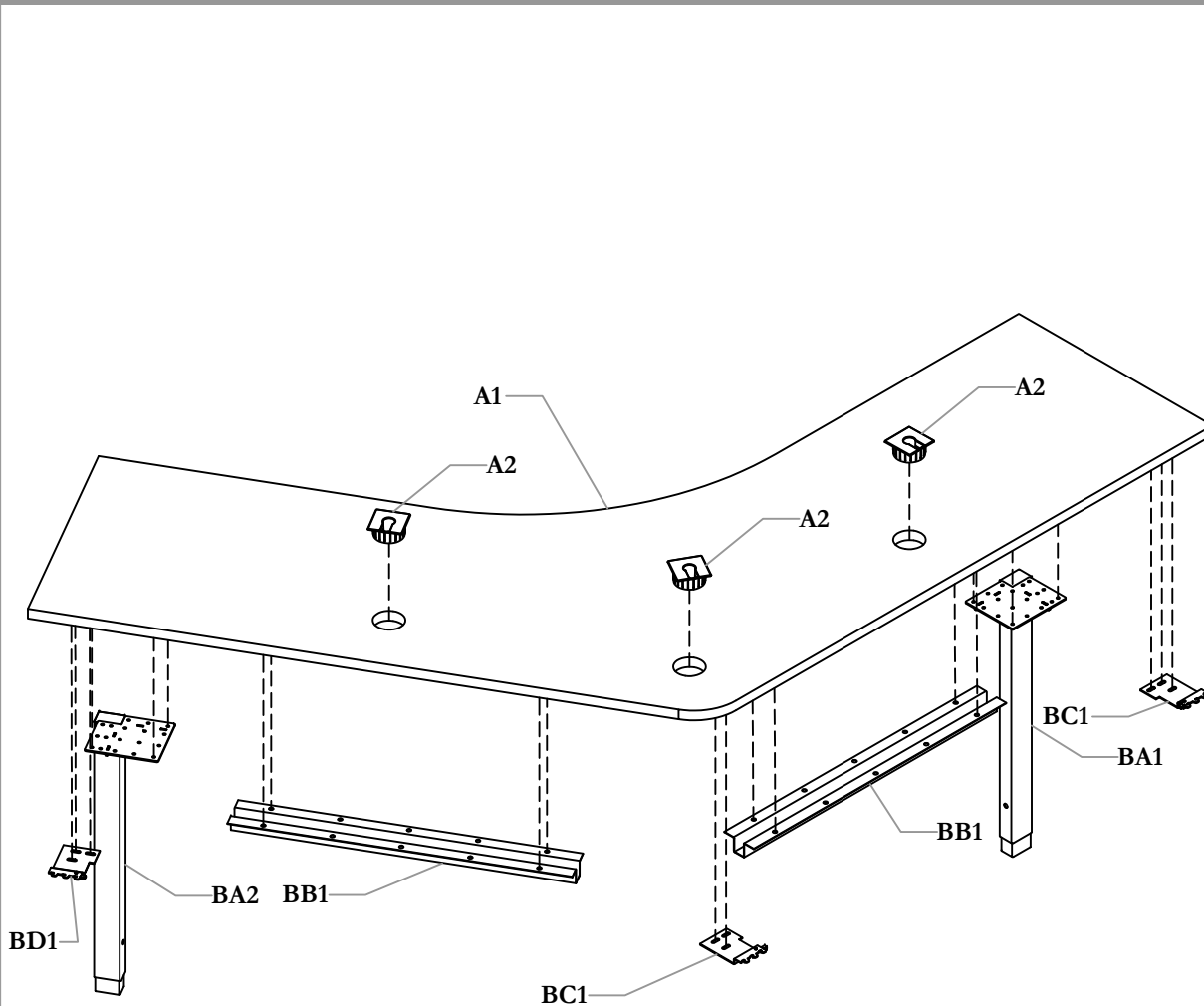

NOTE: Style with all Grommet Holes Shown.

Part and Product Identification

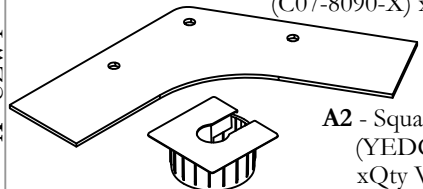
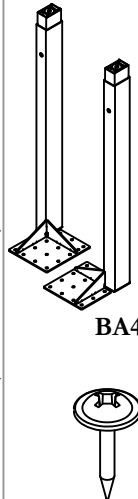
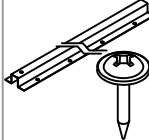
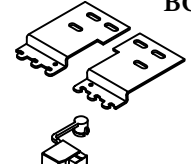
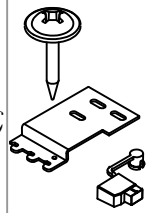
A - UZWT		<p>A1 - Power Spine 120 Hub Worksurface (C07-8090-X) x1</p> <p>A2 - Square Grommet (YEDG2 (N09-1699)) xQty Varies</p>
BA - UZWW		<p>BA1 - Upstage Post Leg - Fix Height - Right (N09-5037R) xQty Varies (Comes Assembled)</p> <p>BA2 - Upstage Post Leg - Fix Height - Left (N09-5037L) xQty Varies (Comes Assembled)</p> <p>BA3 - Upstage Post Leg Cap Assembly (N09-5206) xQty Varies (Comes Assembled)</p> <p>BA4 - Upstage Post Leg Leveler Subassembly (N09-5035) xQty Varies (Comes Assembled)</p> <p>BA5 - #10x0.875" LG. Screw, Quad.Pan Washer (E07-0077) xQty Varies</p>
BB - UNRC		<p>BB1 - Reinforcement Channel (A15-6956-X) xQty Varies</p> <p>BB2 - #10x0.875" LG. Screw, Quad.Pan Washer (E07-0077) xQty Varies</p>
BC - UNIBP		<p>BC1 - Worksurface Panel Bracket - Pair (A15-6949L/R) x1</p> <p>BC2 - #10x0.875" LG. Screw, Quad.Pan Washer (E07-0077) x6</p> <p>BC3 - Bracket Retainer (B02-0242) x2</p>
BD - WorkSurface Panel Bracket Kit (X01-4060L/R) xQty Varies		<p>BD1 - Worksurface Panel Bracket (A15-6949L or R) x1</p> <p>BD2 - Bracket Retainer (B02-0242) x1</p> <p>BD3 - #10x0.875" LG. Screw, Quad.Pan Washer (E07-0077) x3</p>

INSTALL LEGS AND REINFORCEMENT CHANNEL

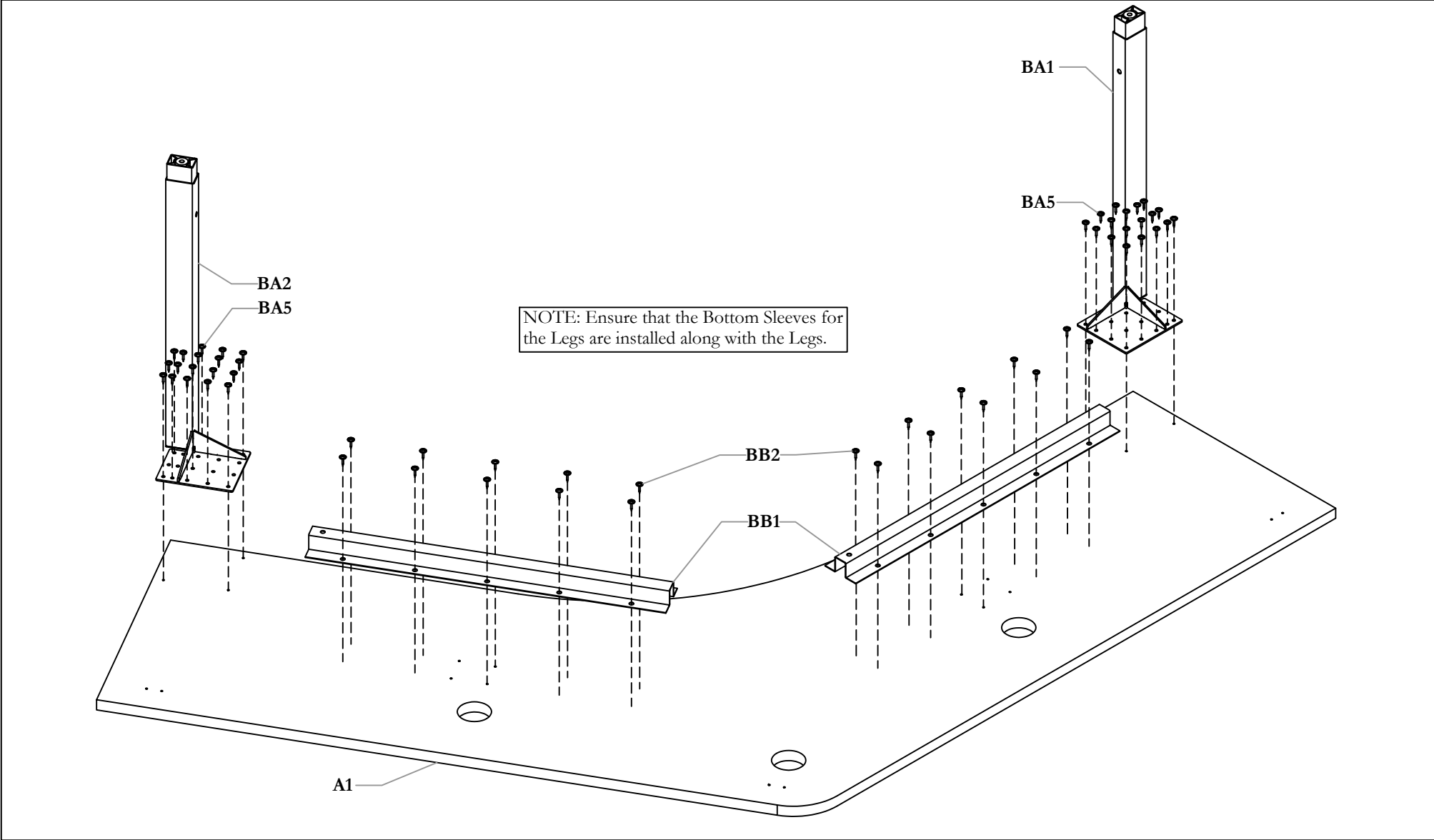

STEP 1: Turn over Work Surface so that the pilot holes are facing up. Screw in the legs and the Reinforcement Channels.

NOTE: Ensure that the Bottom Sleeves for the Legs are installed along with the Legs.

INSTALL BRACKETS ONTO POWER SPINE PANELS

NOTE: Zig Zag Power Spine Assembly with Fascias Shown. Top Trim has been removed for Clarity.

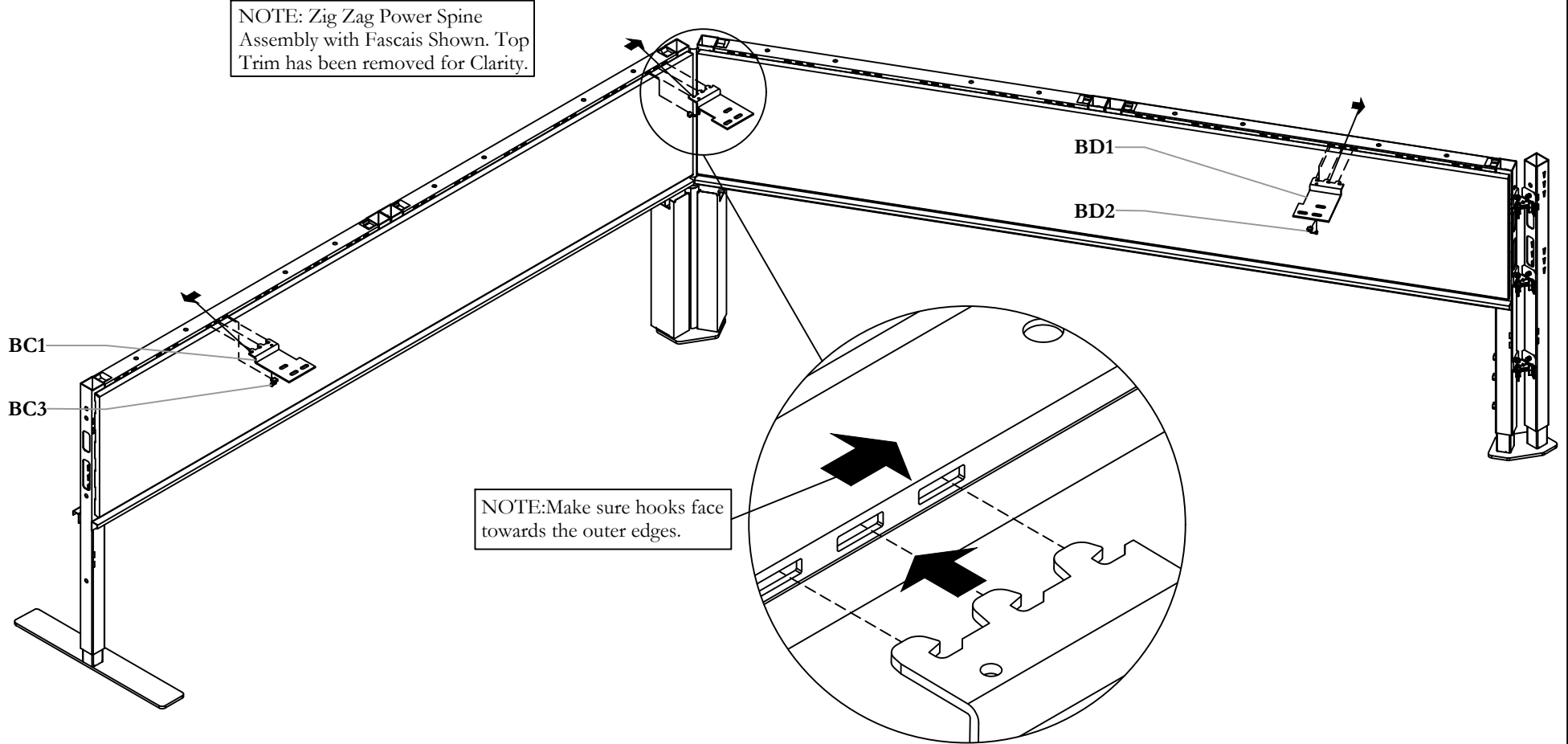

NOTE: Make sure hooks face towards the outer edges.

STEP 2a: Install Brackets onto the Power Spine Panels.

NOTE: Make sure hooks face towards the outer edges.

NOTE: Zig Zag Power Spine Assembly with Fascias Shown. Top Trim has been removed for Clarity.

INSTALL BRACKETS ONTO POWER SPINE PANELS

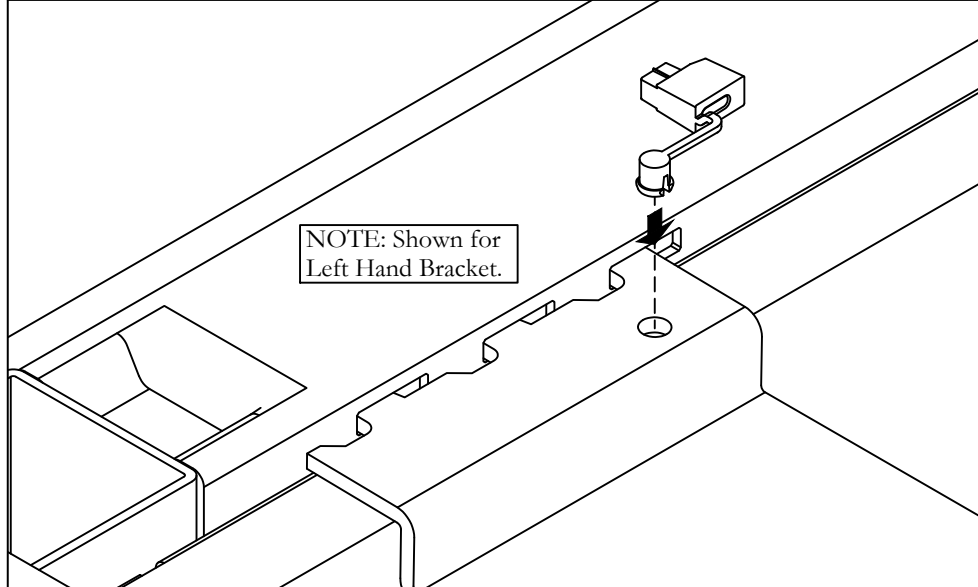
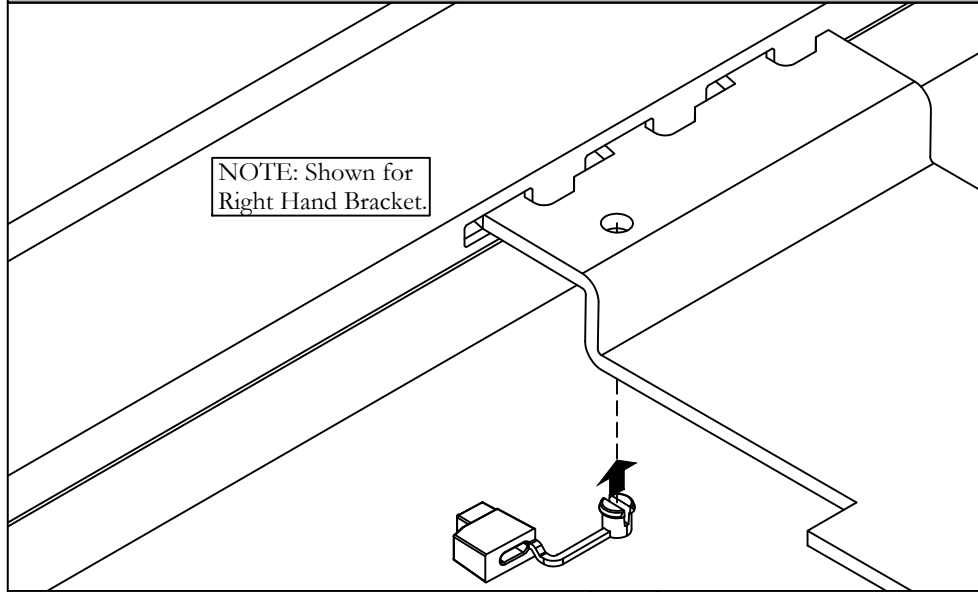

STEP 2b: Secure Bracket Retainer to the Bracket by inserting the circular part of the Retainer into the Bracket's hole.

NOTE: Shown for Right Hand Bracket.
NOTE: Shown for Left Hand Bracket.

INSTALL BRACKETS ONTO POWER SPINE PANELS

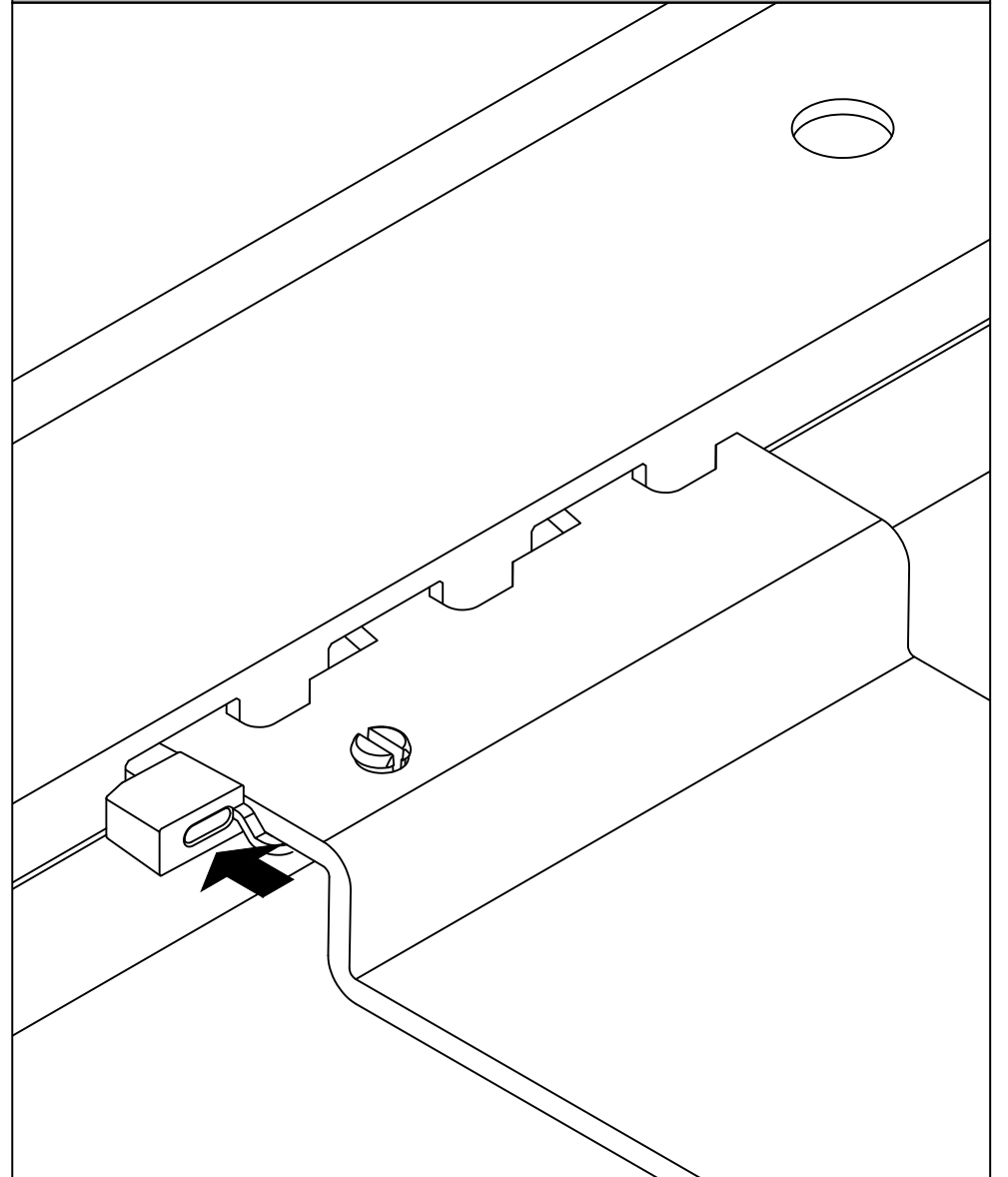

STEP 2c: Insert the Bracket Retainer in the gap that is left by the Bracket to secure the Bracket in place.

ENSURE A 1" GAP

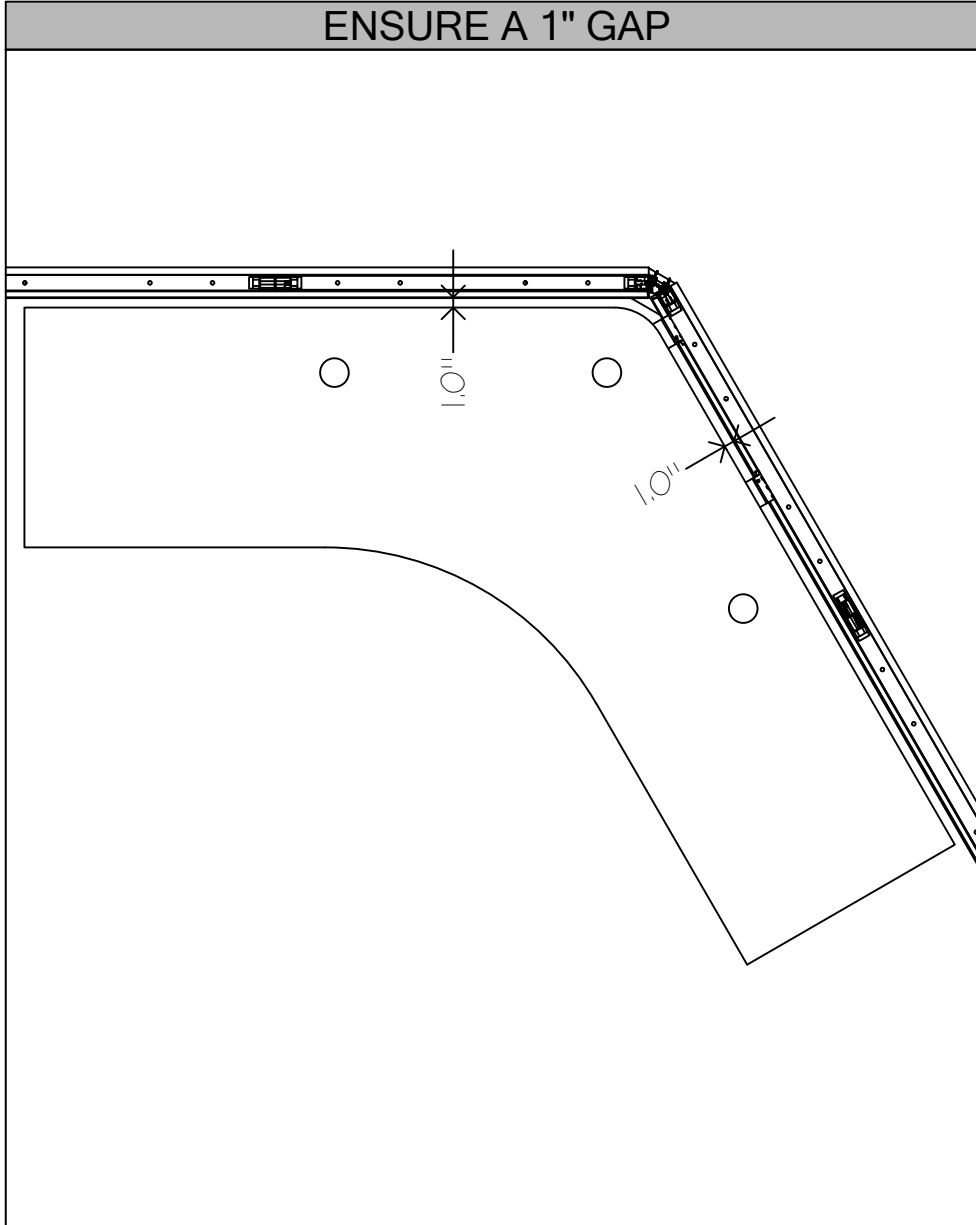

STEP 3a: Turn over the Work Surface so that it is right side up with legs facing the ground. Line up the pilot holes with the Bracket Screw Holes. Ensure a 1" gap between the Fascia and the Work Surface.

SECURE BRACKETS TO WORKSURFACE

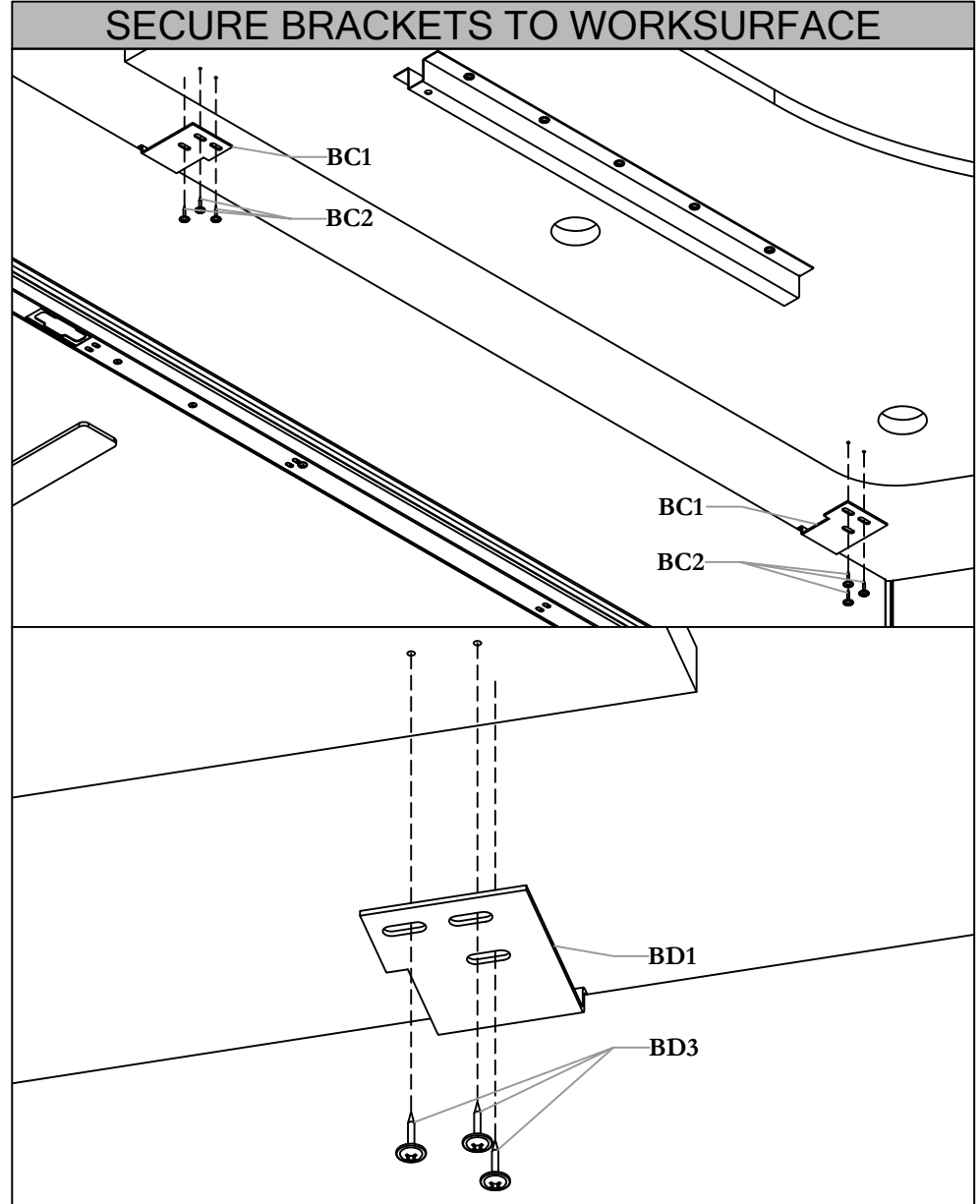

STEP 3b: Secure the Brackets to the Work Surface.

Section: **WORKSURFACES & WORKSURFACE SUPPORTS**

Description: **120 HUB WORKSURFACE**

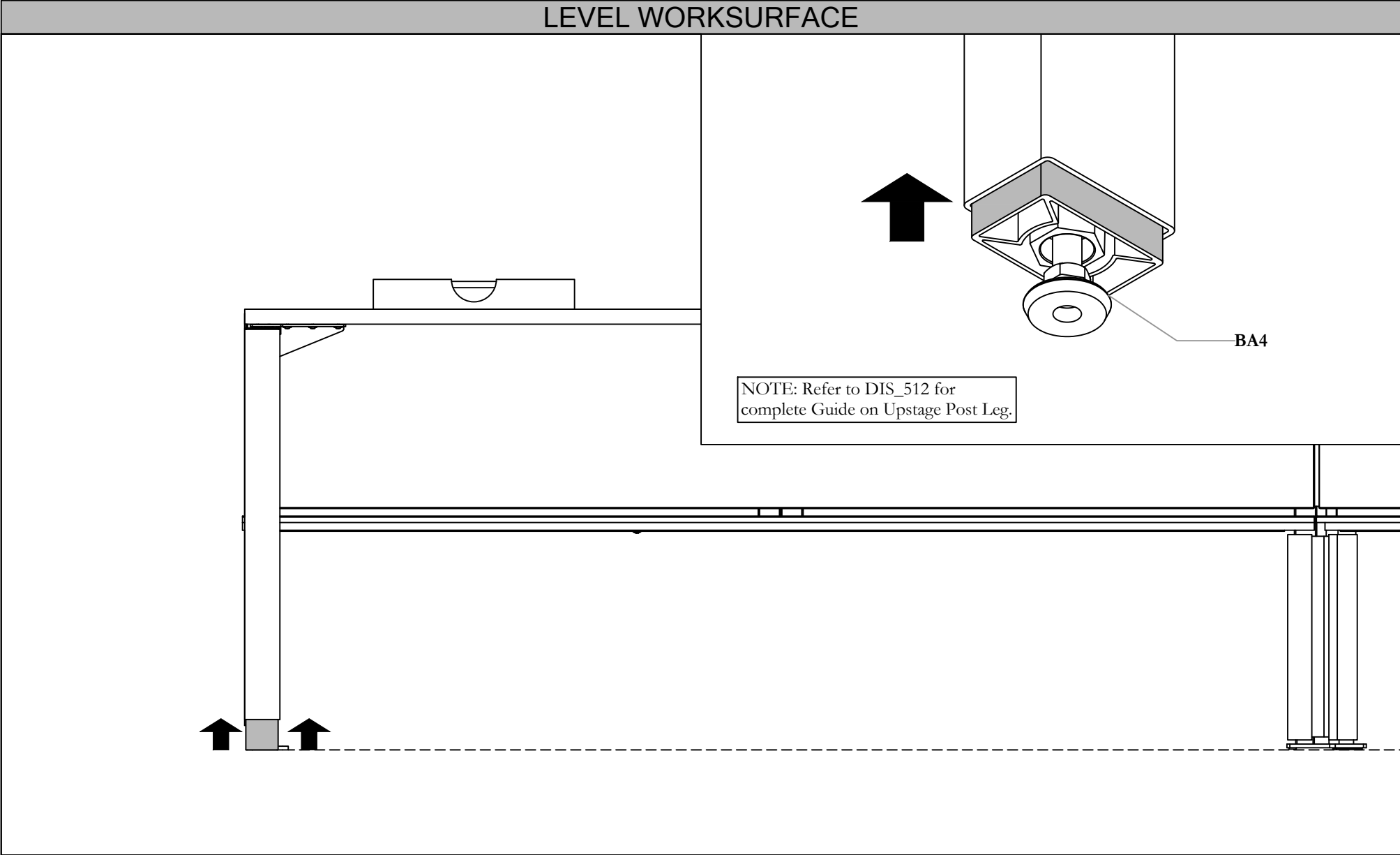

STEP 4: Level the Work Surface by lifting the bottom sleeve to reveal the Leg Leveler. The Leveler is a Right-Hand Thread, right spin to lower level and left spin to raise level.

NOTE: Refer to DIS_512 for complete Guide on Upstage Post Leg.

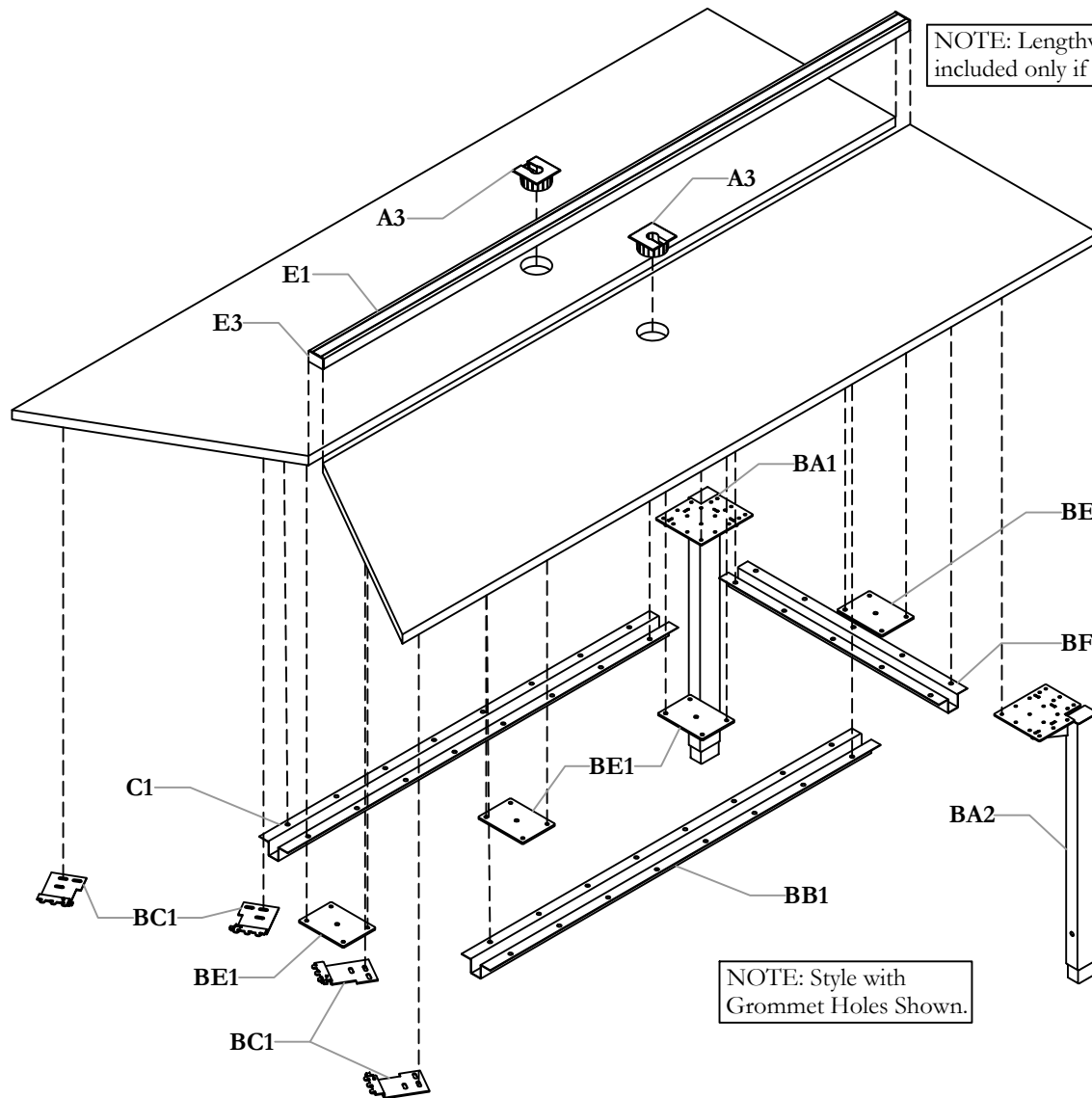

Dual 120 Angled WorkSurface (UZWD), 120 Angled WorkSurface Support Bundle (UZDK)



NOTE: Lengthwise Reinforcement Channels included only if Worksurface length is 60" or greater.

NOTE: Style with Grommet Holes Shown.

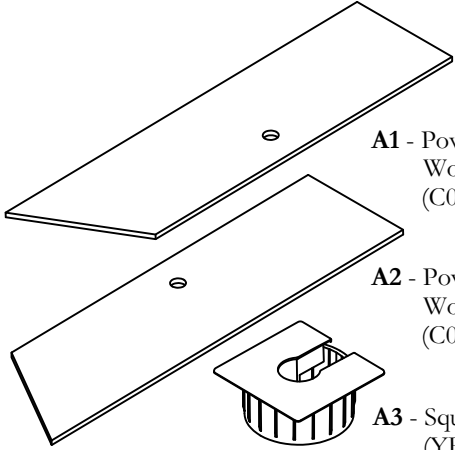
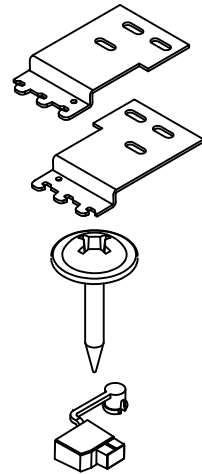
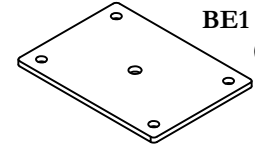
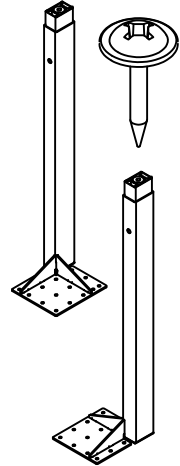
Part and Product Identification

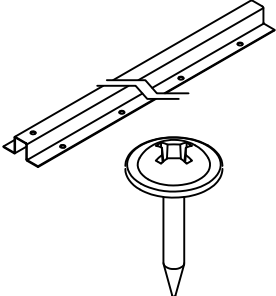
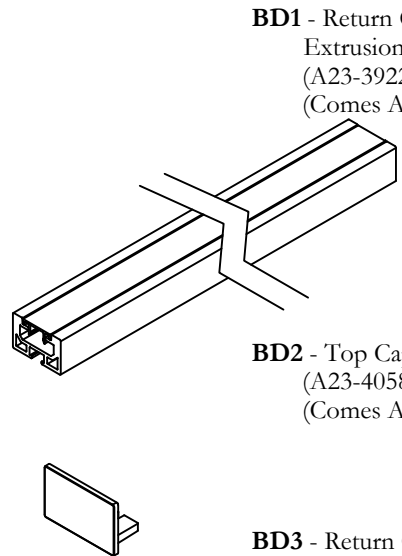
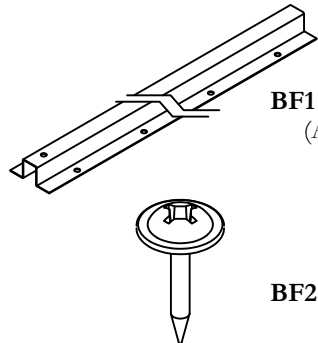
A - UZWD		B - UZDK	
 <p>A1 - Power Spine Dual Parallelogram Worksurface Perpendicular (C07-8126LX-X) x1</p> <p>A2 - Power Spine Dual Parallelogram Worksurface Perpendicular (C07-8126RX-X) x1</p> <p>A3 - Square Grommet (YEDG2 (N09-1699) x0 or 2</p>		 <p>BC1 - Worksurface Panel Bracket - Pair (A15-6949L/R) x2</p> <p>BC2 - #10x0.875" LG. Screw, Quad.Pan Washer (E07-0077) x12</p> <p>BC3 - Bracket Retainer (B02-0242) x4</p>	
BA - Upstage Post Leg - Fix Height (N09-5028L/R)	B - UZDK	BD1 - Return Center Rail Extrusion (A23-3922-X) x1 (Comes Assembled)	 <p>BE1 - Rail Mounting Plate (A16-6709) x4</p>
	 <p>BA1 - Upstage Post Leg - Fix Height - Right (N09-5037R) x1 (Comes Assembled)</p> <p>BA2 - Upstage Post Leg - Fix Height - Left (N09-5037L) x1 (Comes Assembled)</p> <p>BA3 - Upstage Post Leg Cap Assembly (N09-5206) x2 (Comes Assembled)</p> <p>BA4 - Upstage Post Leg Leveler Subassembly (N09-5035) x2 (Comes Assembled)</p> <p>BA5 - #10x0.875" LG. Screw, Quad.Pan Washer (E07-0077) x36</p>		 <p>BE2 - Hex Bolt 5/16-18x1" LG ZP (E03-0641) x4</p> <p>BE3 - 5/16-18 Hex Nut, 1/2 A/F, 0.265 THK (E01-0755) x4</p>
BB - UNRC	 <p>BB1 - Reinforcement Channel (A15-6956-X) x0 or 2</p> <p>BB2 - #10x0.875" LG. Screw, Quad.Pan Washer (E07-0077) xQty Varies</p>	 <p>BD2 - Top Cap Extrusion (A23-4058-X) x1 (Comes Assembled)</p> <p>BD3 - Return Center Rail End Cap Assembly (N02-2151) x2</p>	 <p>BF1 - Reinforcement Channel (A15-6956-X) x1</p> <p>BF2 - #10x0.875" LG. Screw, Quad.Pan Washer (E07-0077) xQty Varies</p>

INSTALL LEGS, REINFORCEMENT CHANNELS & MOUNTING PLATES

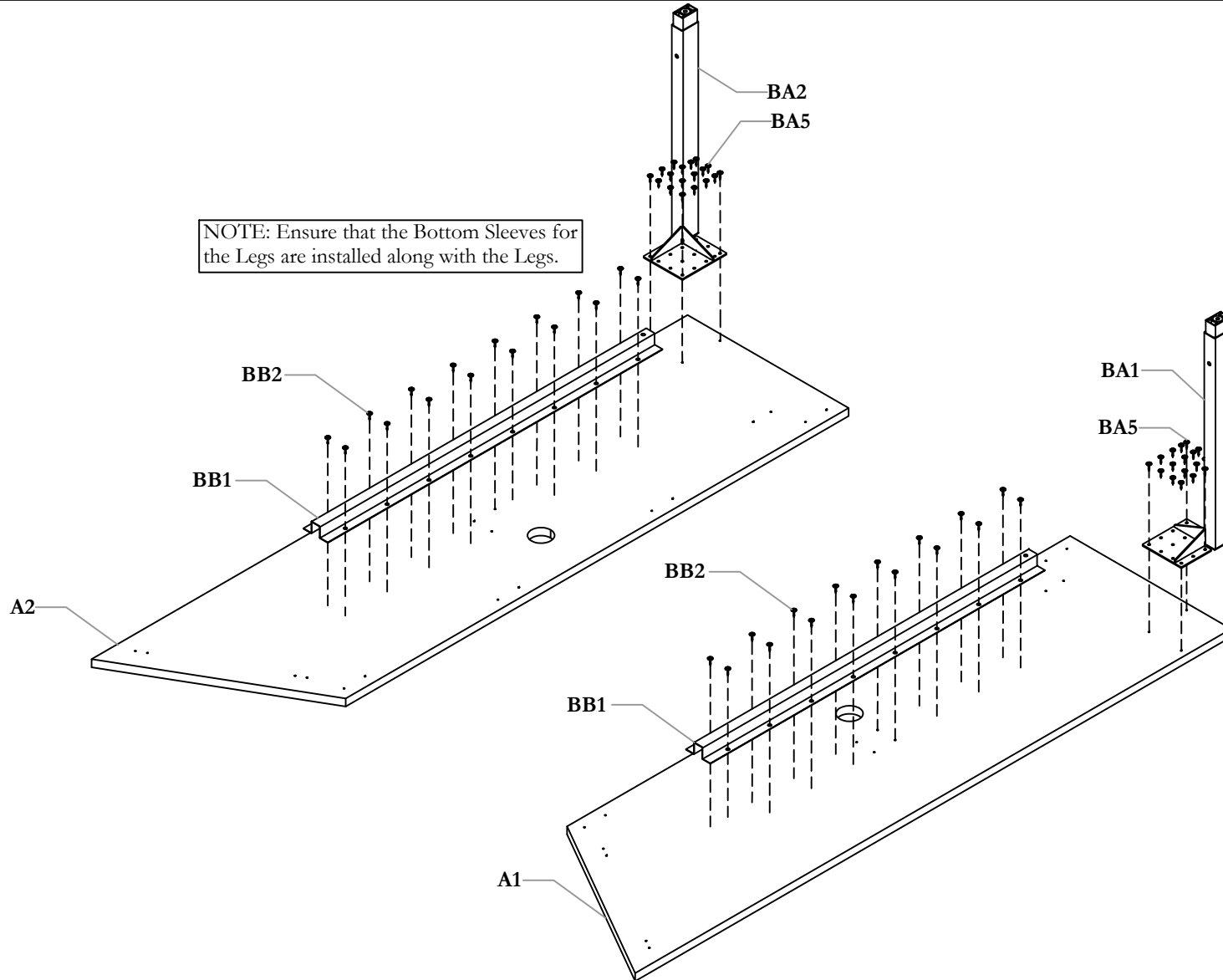

STEP 1a: Turn over both WorkSurfaces (A1 & A2) so that the pilot holes are facing up. Screw (BB2) in the legs (BA1) and the lengthwise Reinforcement Channels.

NOTE: Ensure that the Bottom Sleeves for the Legs are installed along with the Legs.

INSTALL PERPENDICULAR REINFORCEMENT CHANNEL & MOUNTING PLATES

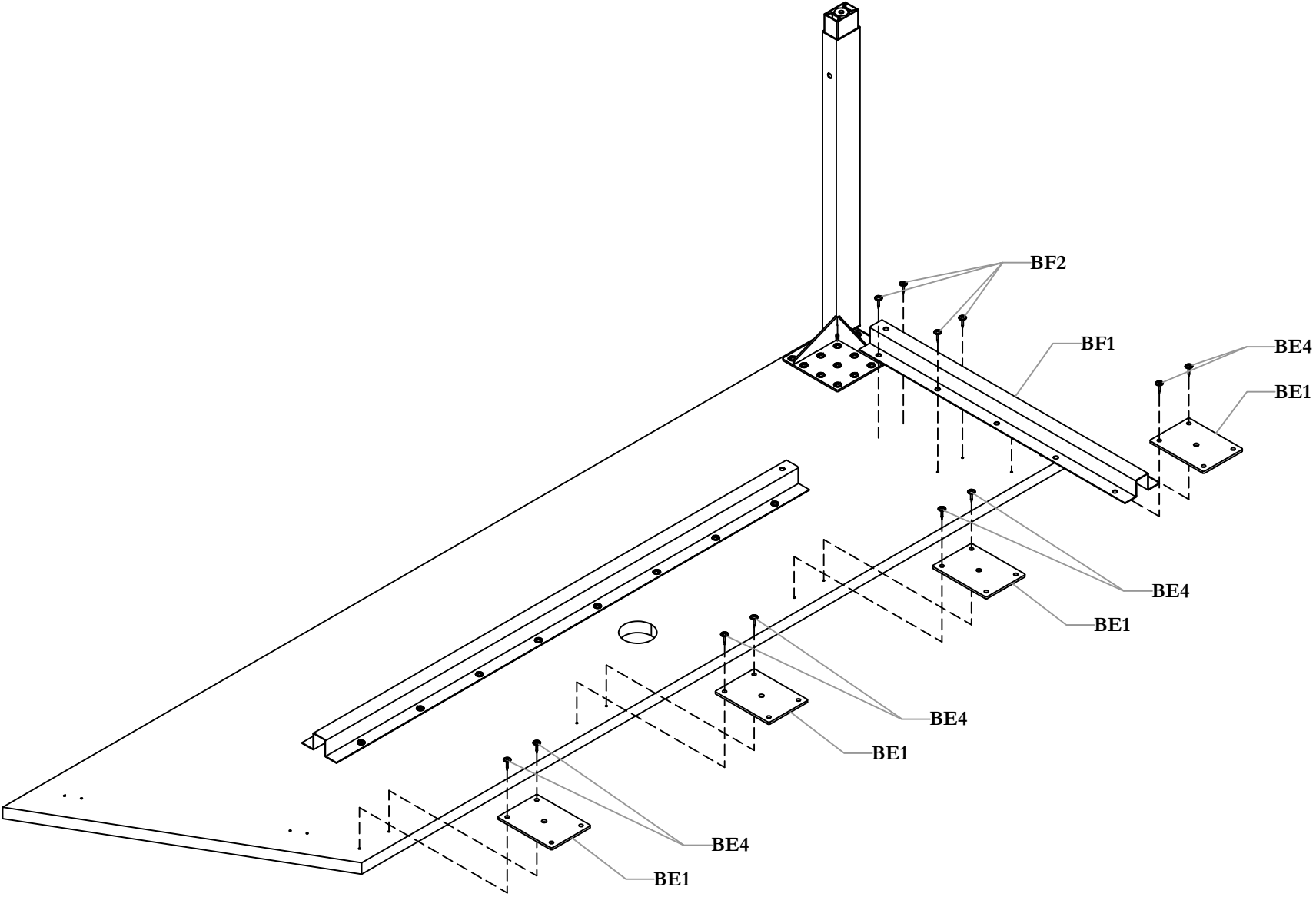

STEP 1b: Screw in the Rail Mounting Plates (BE1) and perpendicular Reinforcement Channel (BF1) onto one of the WorkSurfaces.

INSTALL BRACKETS ONTO POWER SPINE PANELS

NOTE: Alternate between left hand and right hand brackets.

NOTE: Make sure hooks engage towards the outer edges.

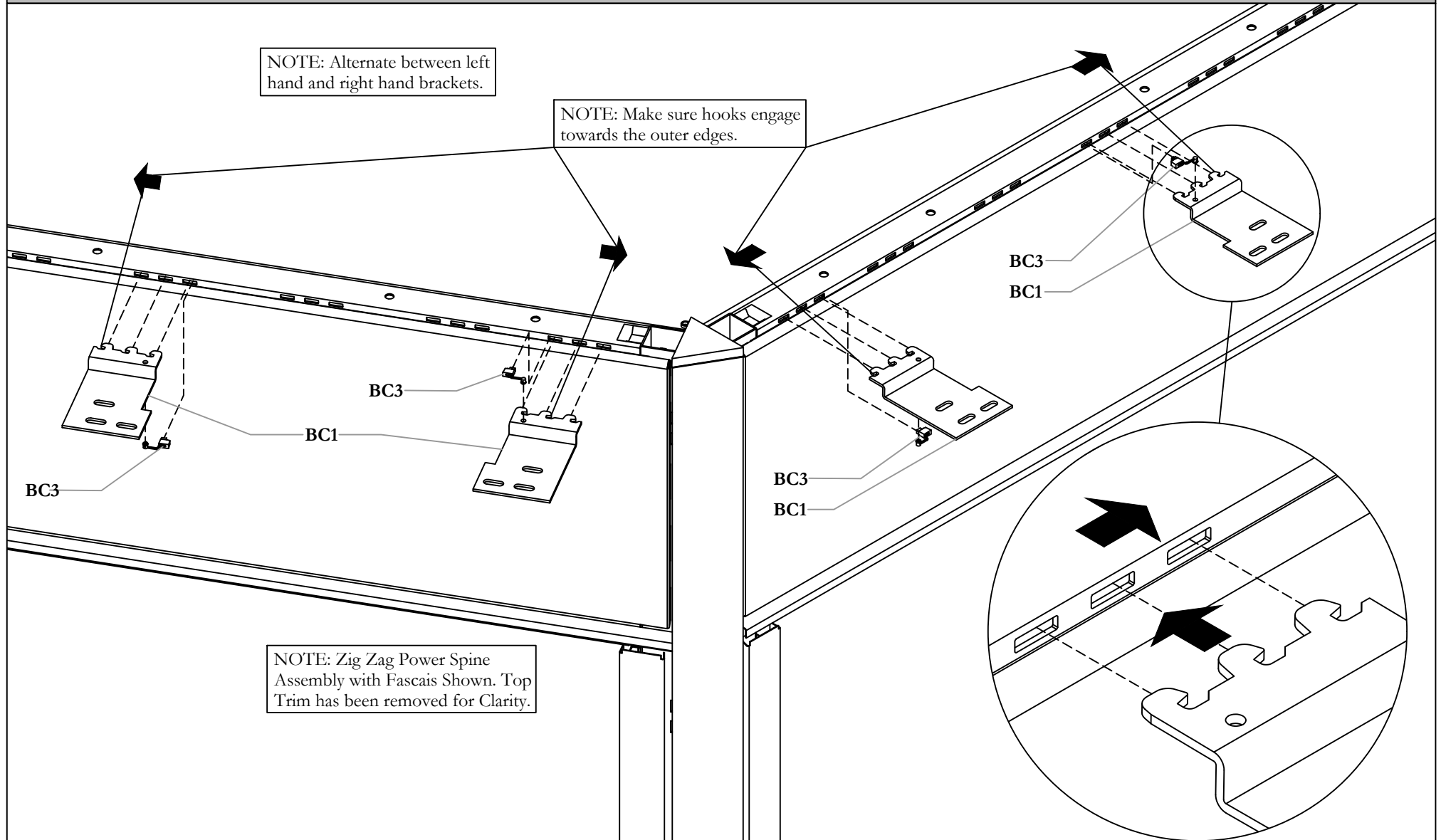

NOTE: Zig Zag Power Spine Assembly with Fascias Shown. Top Trim has been removed for Clarity.

STEP 2a: Install Brackets (BC1) onto the Power Spine Panels.

NOTE: Alternate between left hand and right hand brackets.

NOTE: Make sure hooks engage towards outer edges.

NOTE: Zig Zag Power Spine Assembly with Fascias Shown. Top Trim has been removed for Clarity.

Section: **WORKSURFACES & WORKSURFACE SUPPORTS**

Description: **DUAL 120 ANGLED WORKSURFACE**

INSTALL BRACKETS ONTO POWER SPINE PANELS

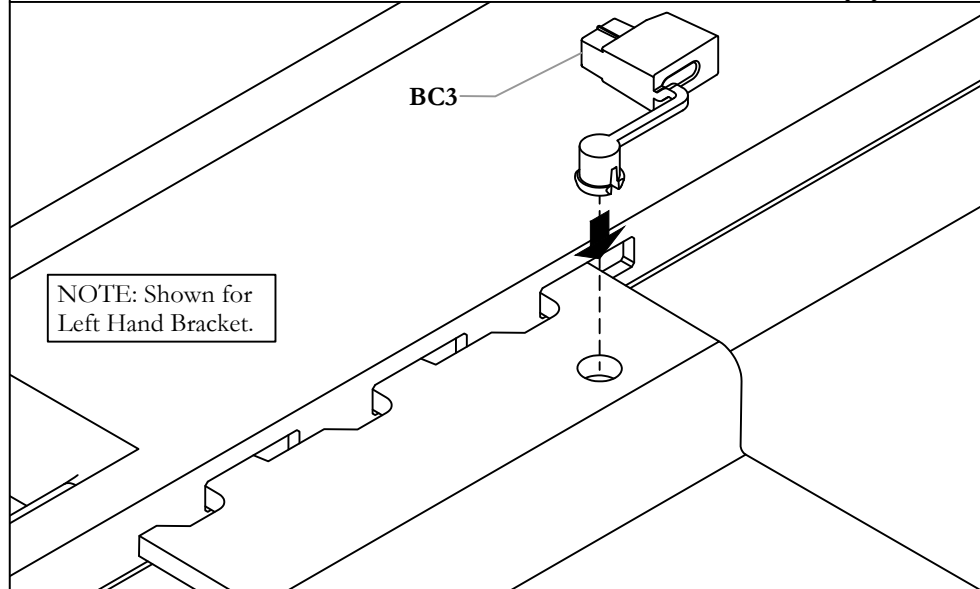
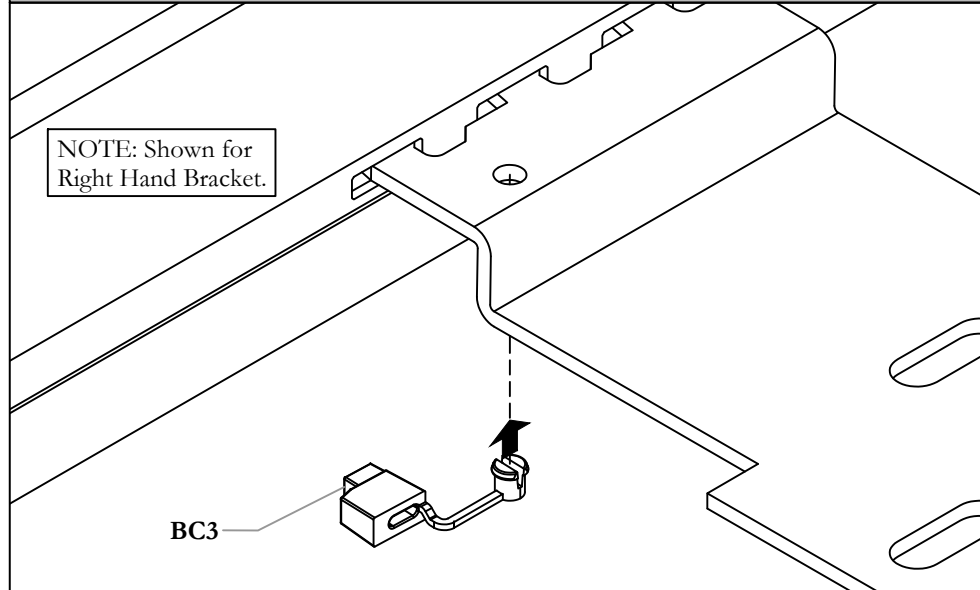

STEP 2b: Secure Bracket Retainer (BC3) to the Bracket (BC1) by inserting the circular part of the Retainer into the Bracket's hole.

NOTE: Shown for Right Hand Bracket.
NOTE: Shown for Left Hand Bracket.

INSTALL BRACKETS ONTO POWER SPINE PANELS

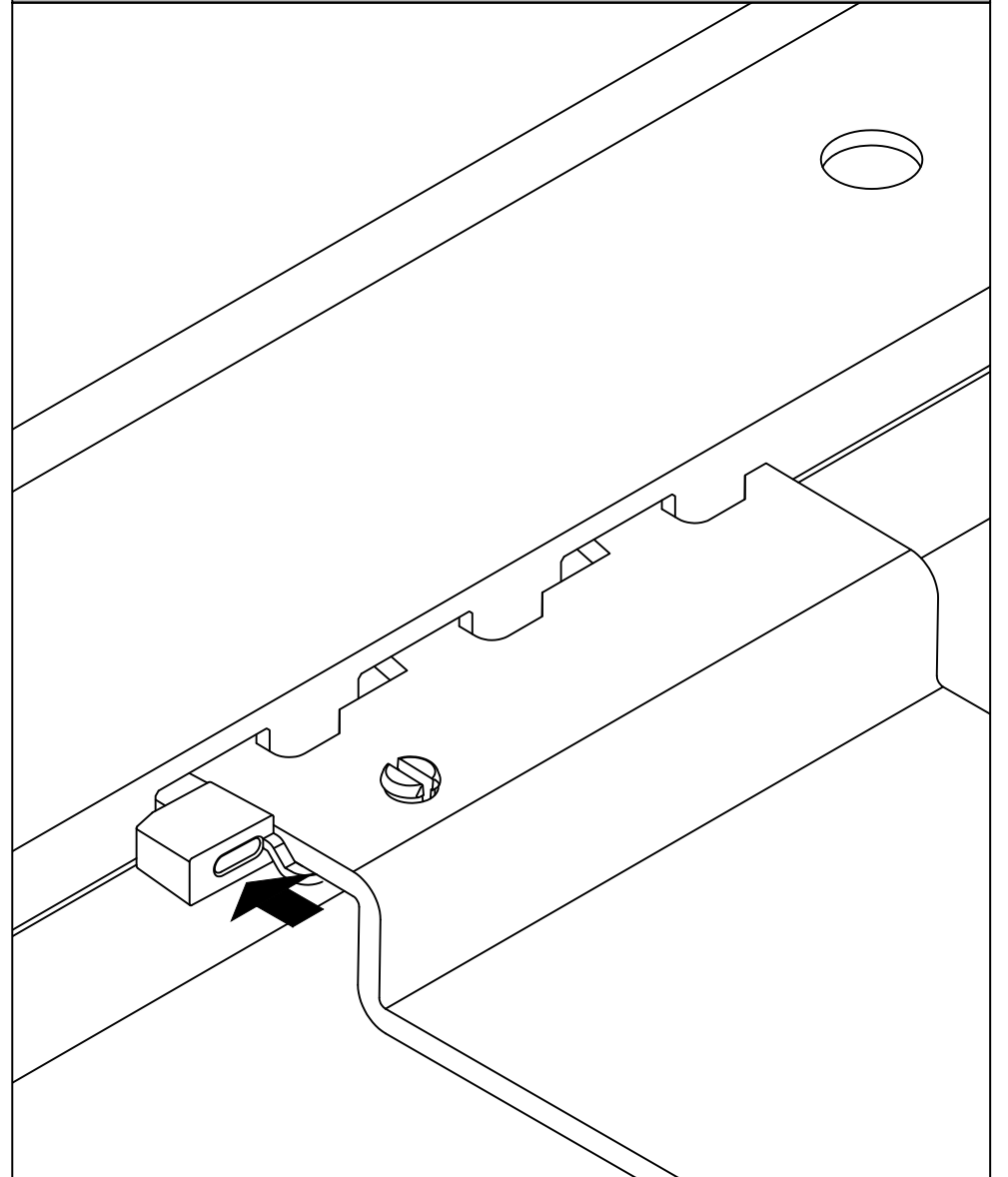

STEP 2c: Insert the Bracket Retainer (BC3) in the gap that is left by the Bracket to secure the Bracket in place.

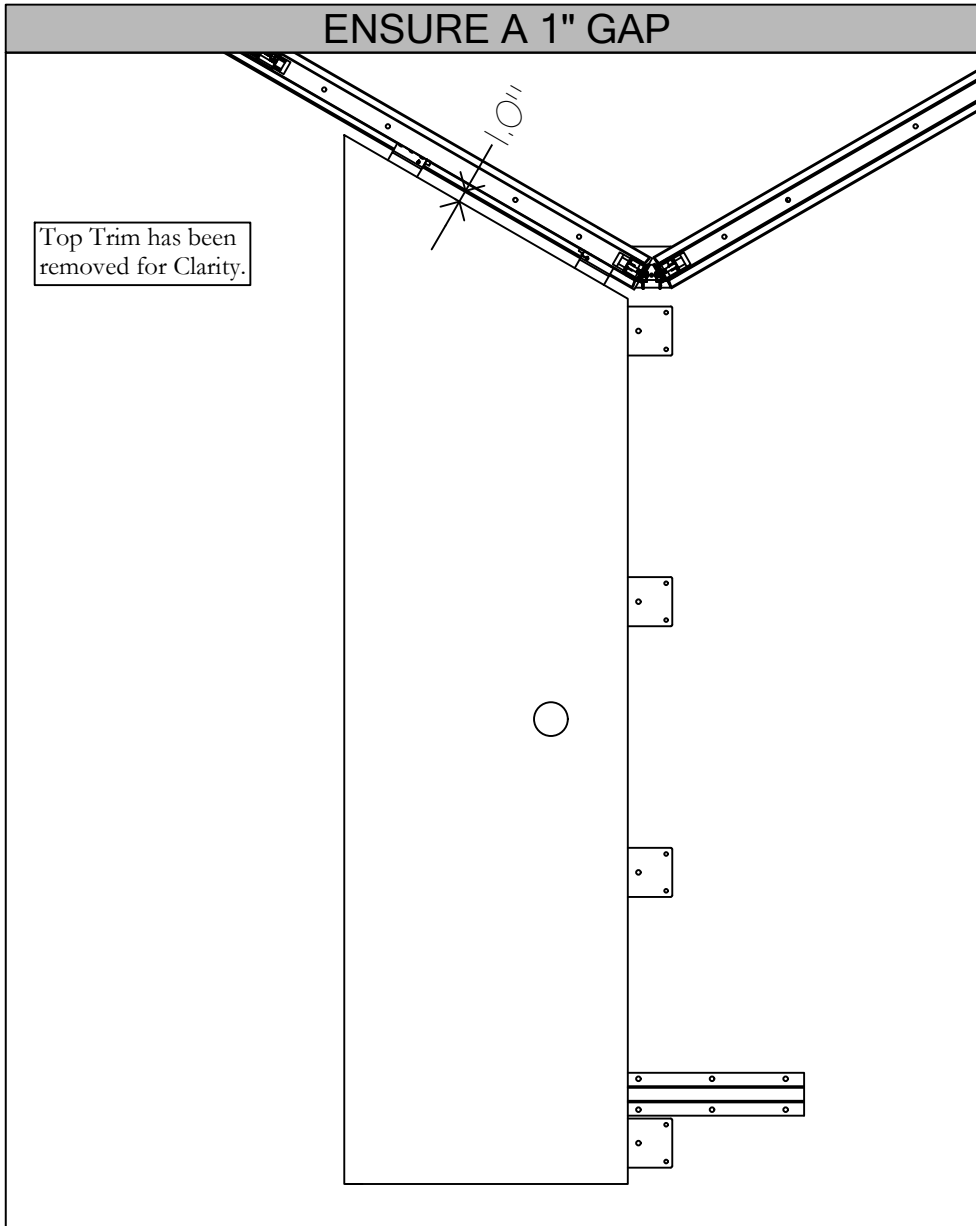

STEP 3a: Turn over the WorkSurface that has the perpendicular Reinforcement Channel and Mounting Plates secured to it so that it is right side up with legs facing the ground. Line up the pilot holes with the Bracket Screw Holes. Ensure a 1" gap between the Fascia and the Work Surface.

NOTE: Top Trim has been removed for Clarity.

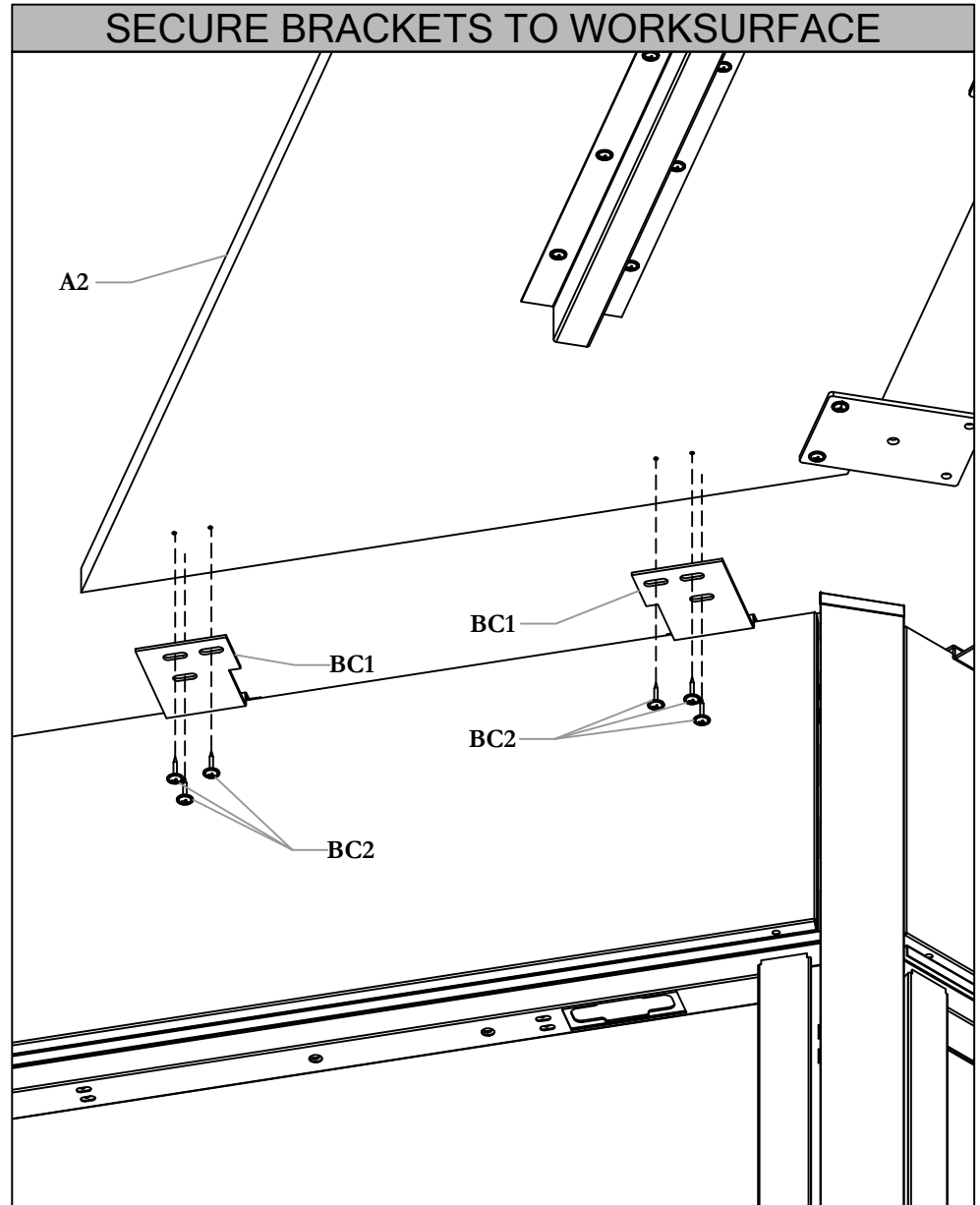

STEP 3b: Secure the Brackets (BC1) to the Work Surface (A1 & A2).

INSERT HEX BOLTS INTO CENTER RAIL

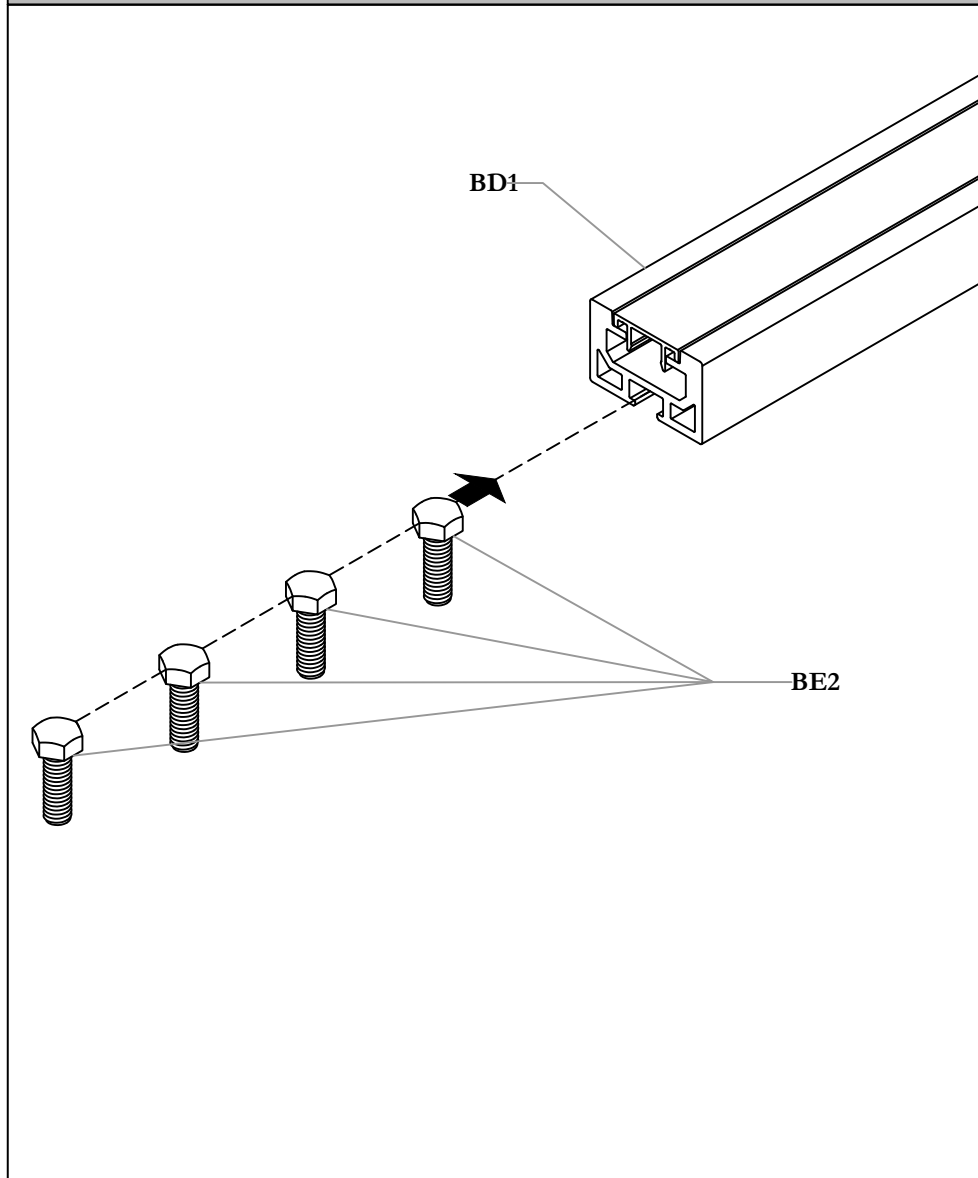

STEP 4a: Insert Hex Bolts (BE2) into the Center Rail (BD1) so that they stick out from the bottom

PLACE CENTER RAIL ONTO MOUNTING PLATES

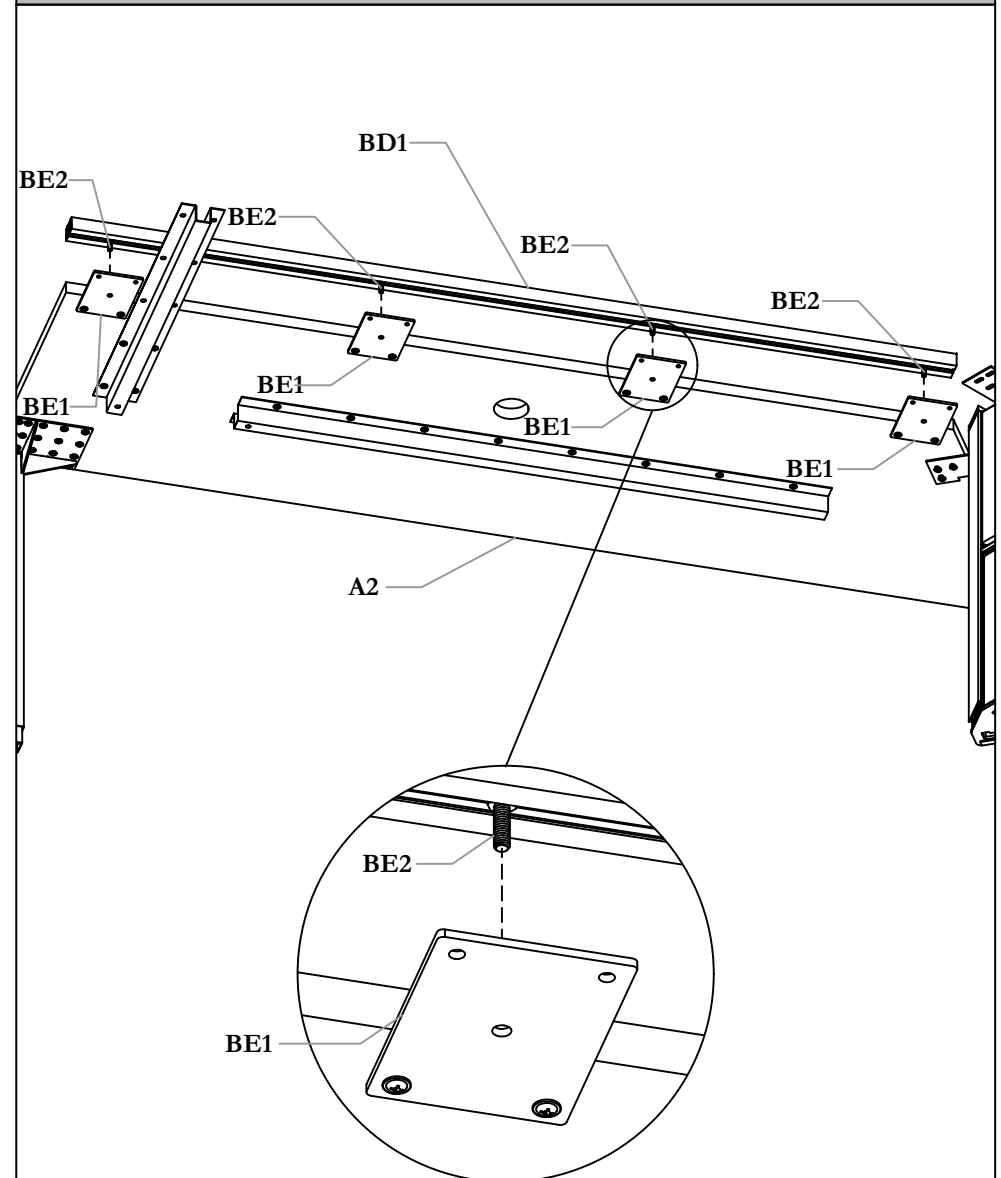

STEP 4b: Line up the Hex Bolts (BE2) within the Center Rail with the center holes in the Mounting Plate (BE1) and let the Center Rail rest on the Mounting Plates.

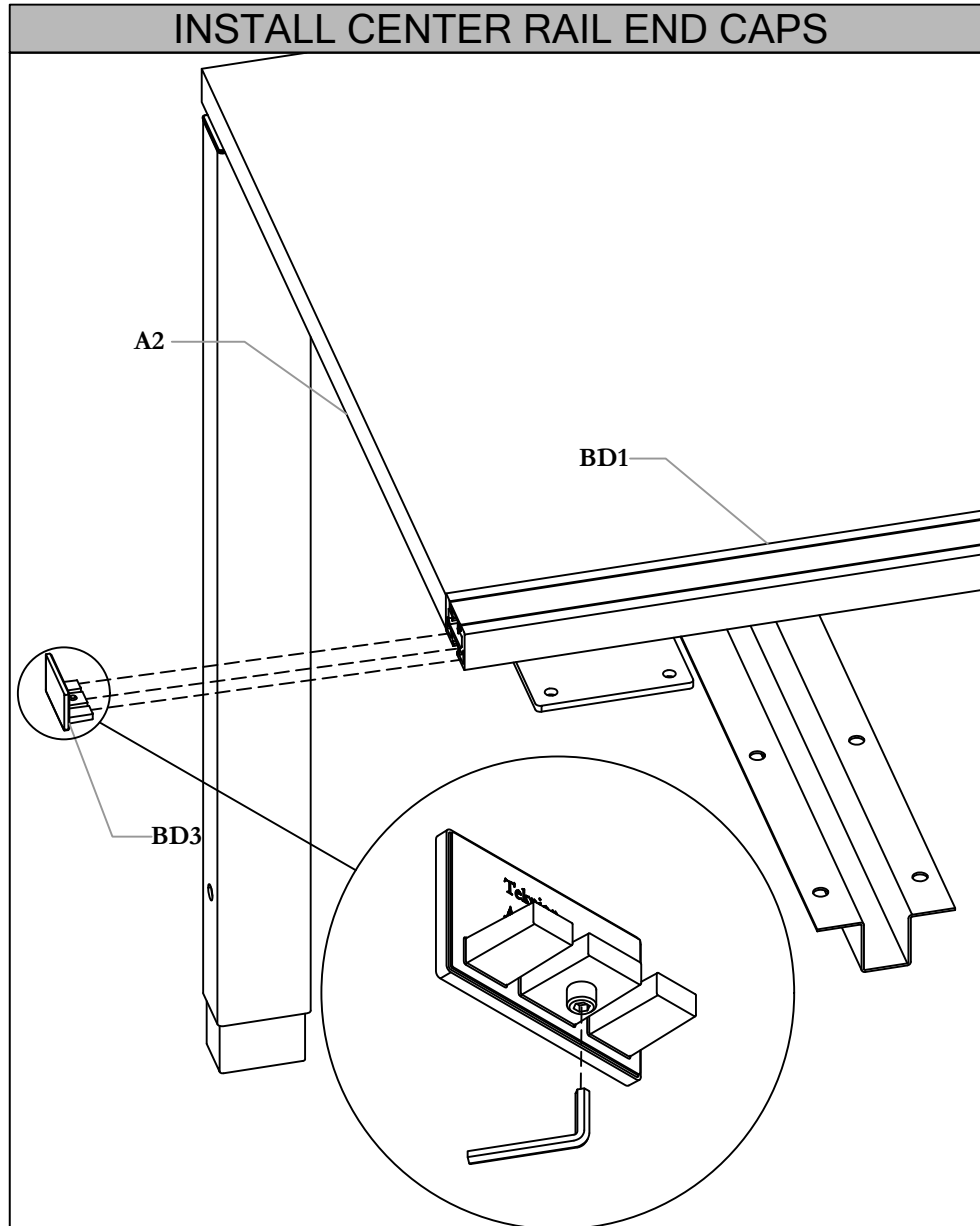

STEP 5: Install the Return Center Rail End Cap Assemblies (BD1) to both sides of the Return Center Rail (BD3)

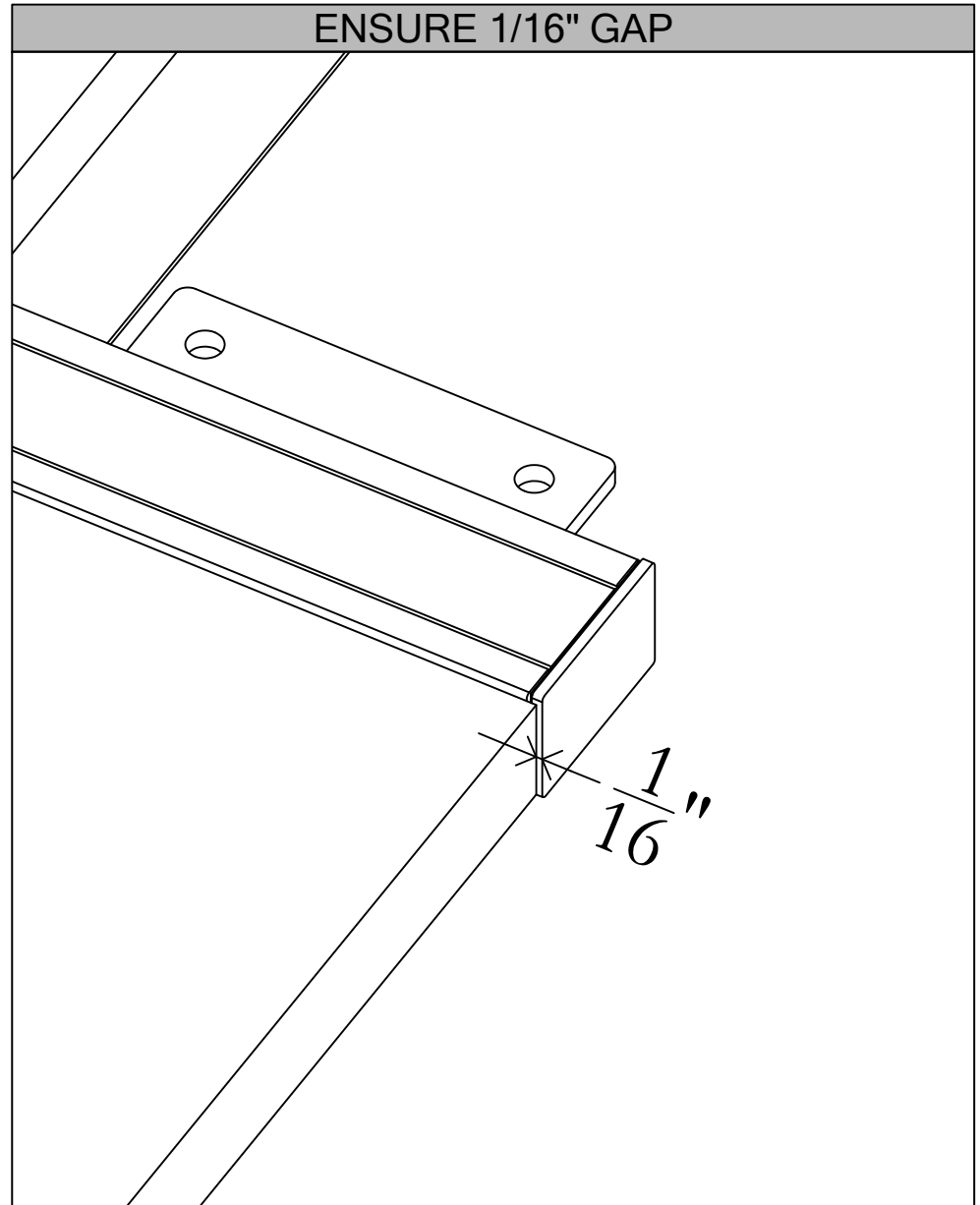

STEP 6: Ensure a 1/16" gap between the End Cap Assembly and the WorkSurface edge on the the open side of the Assembly.

SECURE CENTER RAIL

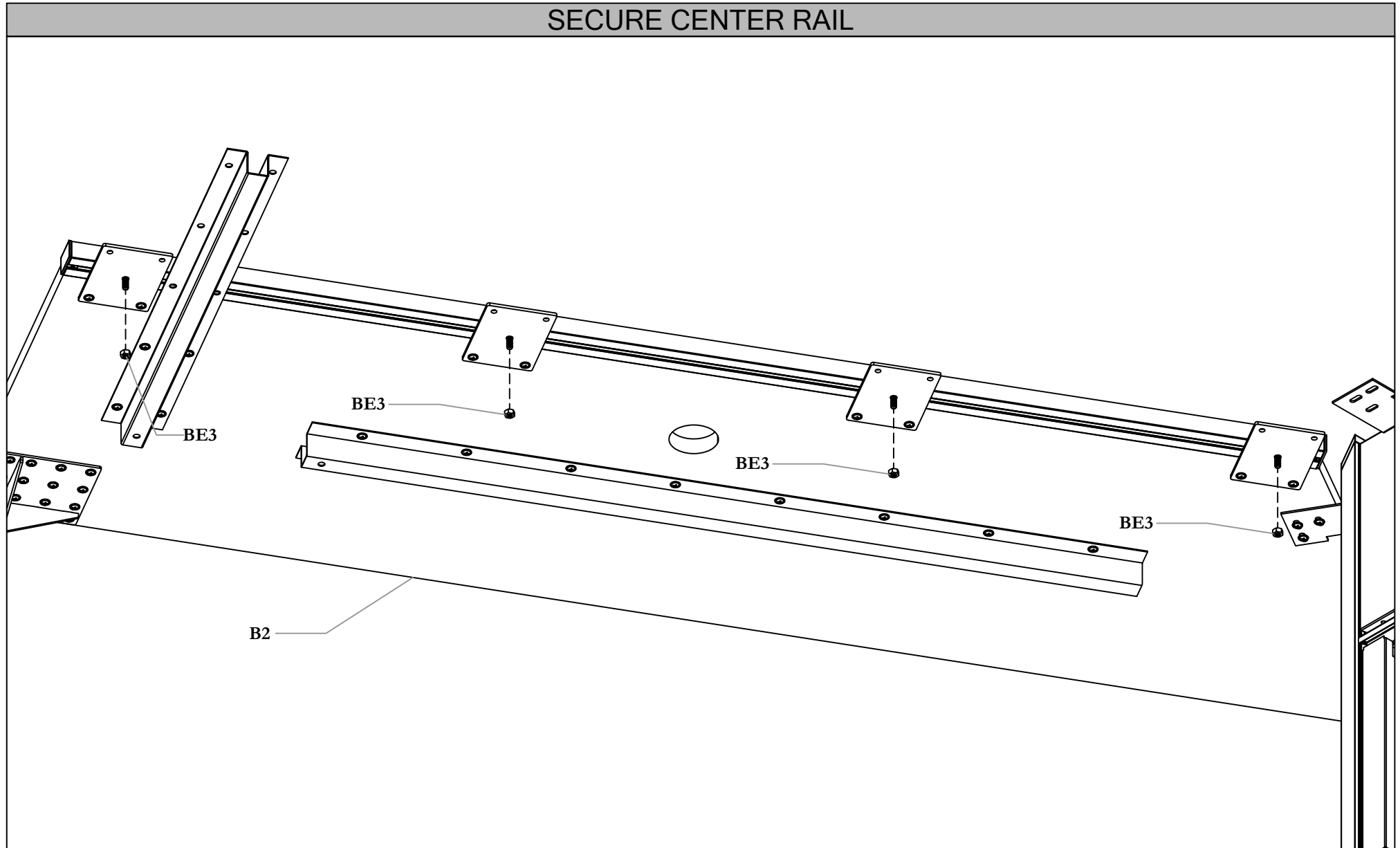

STEP 7: Tighten Hex Nuts (BE3) onto the Hex Bolts (BE2) to secure the Center Rail in place.

SECURE CENTER RAIL

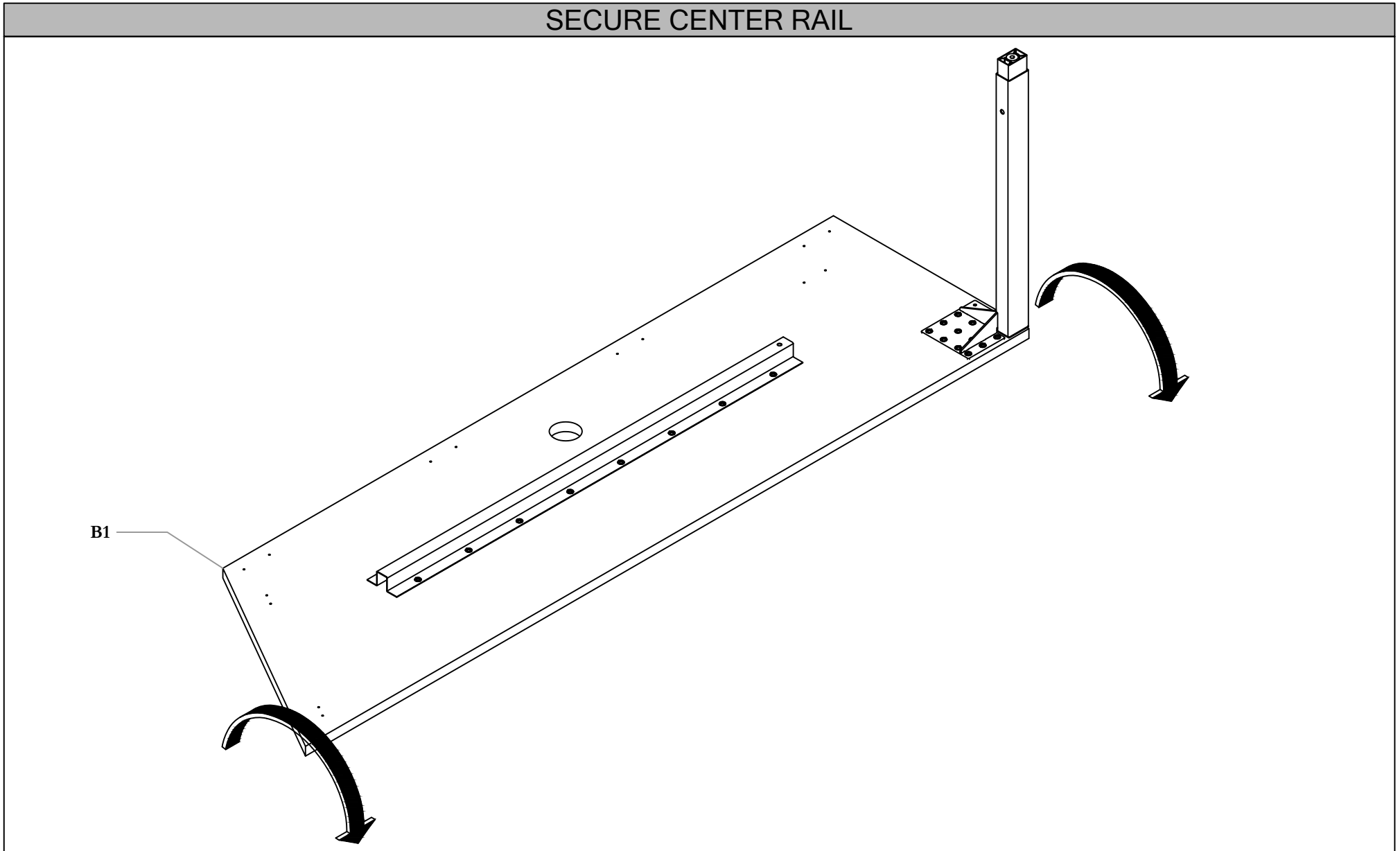

STEP 8a: Turn over the other WorkSurface and align it on the other side of the Center Rail.

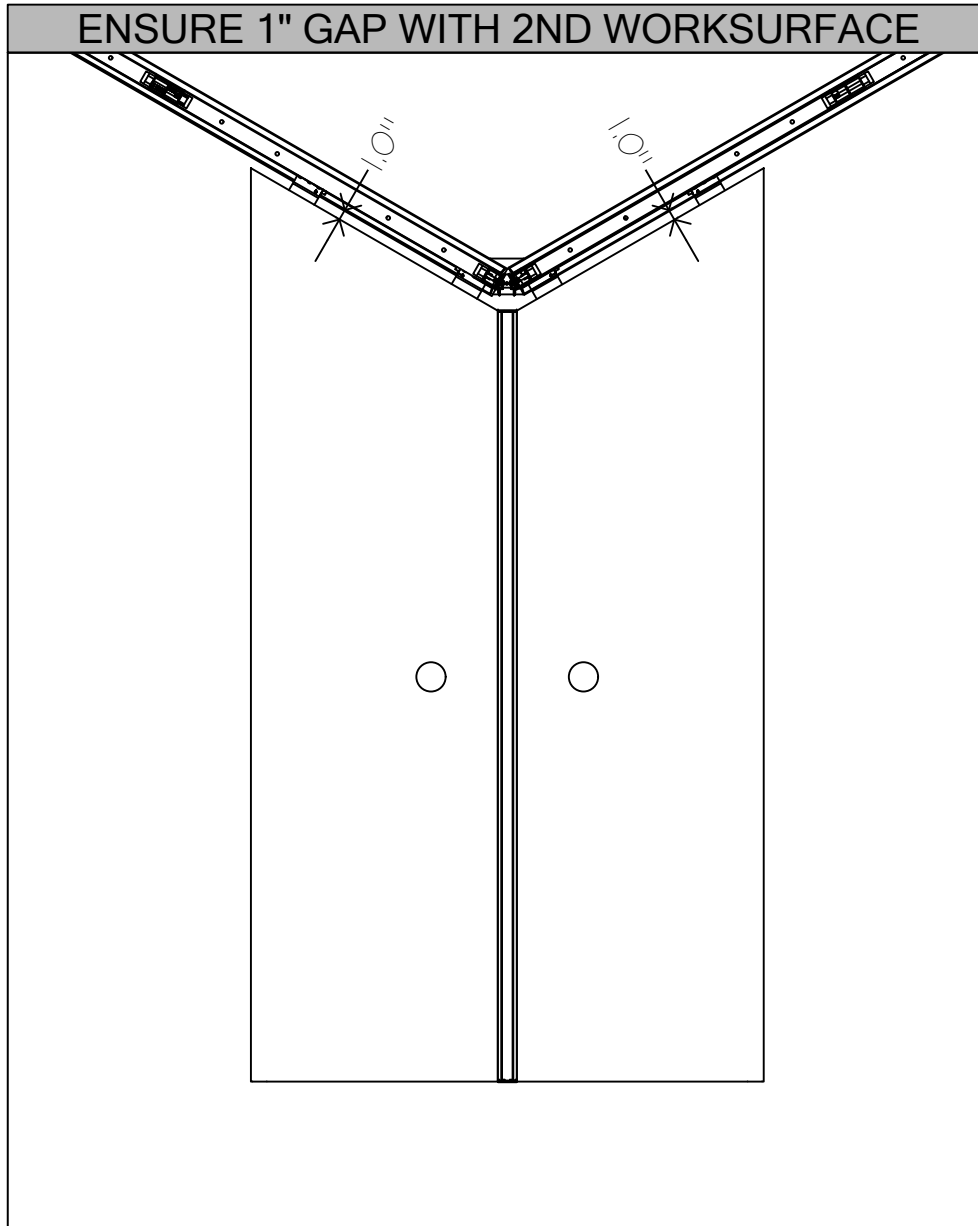

STEP 8b: Line up the other WorkSurface with the Rail, making sure that the WorkSurface Edges are aligned. Make sure to ensure a 1" gap between the Work Surface and the Fascias on the Power Spine Panels.

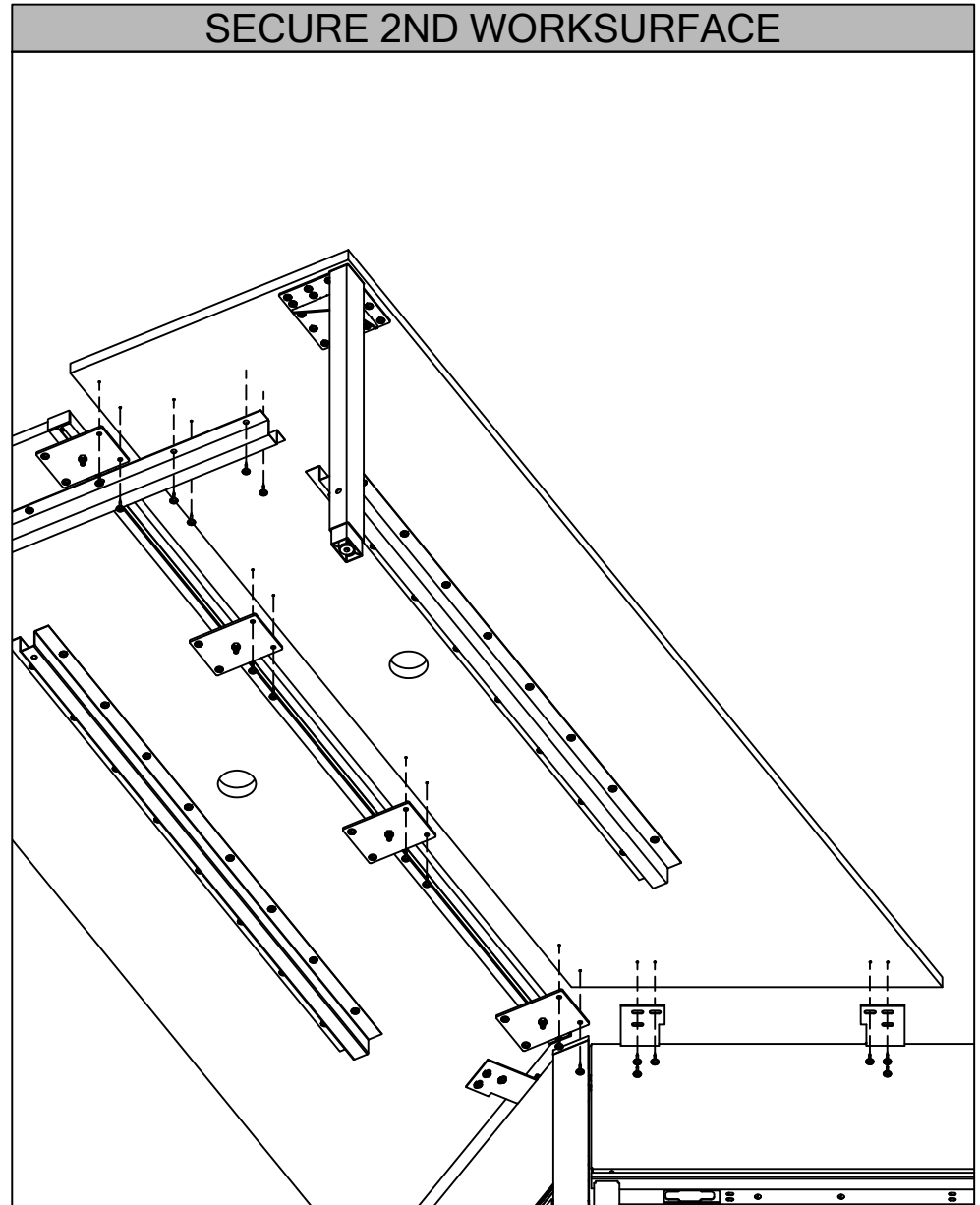

STEP 8c: Secure the WorkSurface to the Brackets, Mounting Plates and perpendicular Reinforcement Channel.

LEVEL WORKSURFACE

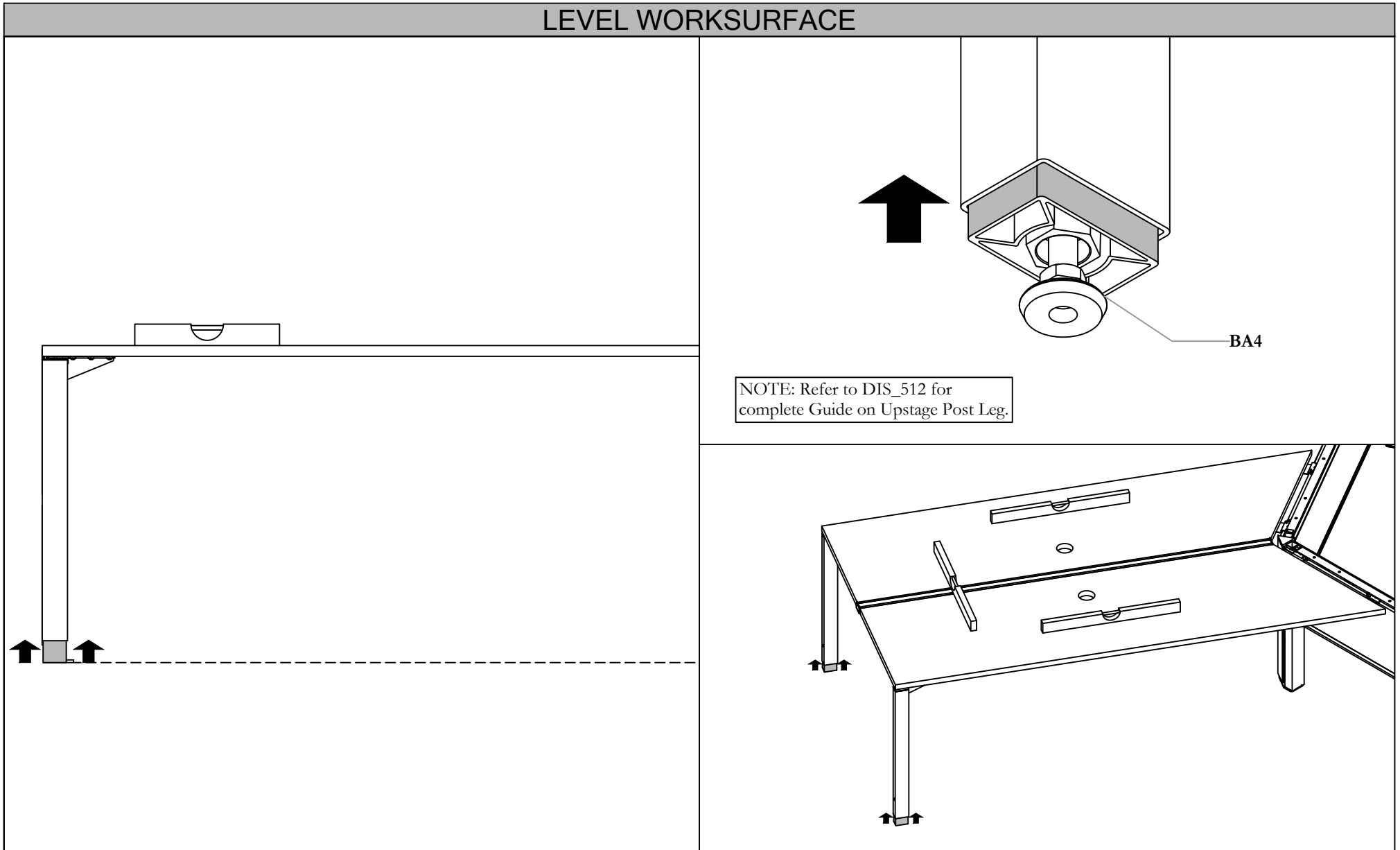

STEP 9: Level the Work Surface by lifting the bottom sleeve to reveal the Leg Leveler. The Leveler is a Right-Hand Thread, right spin to lower level and left spin to raise level.







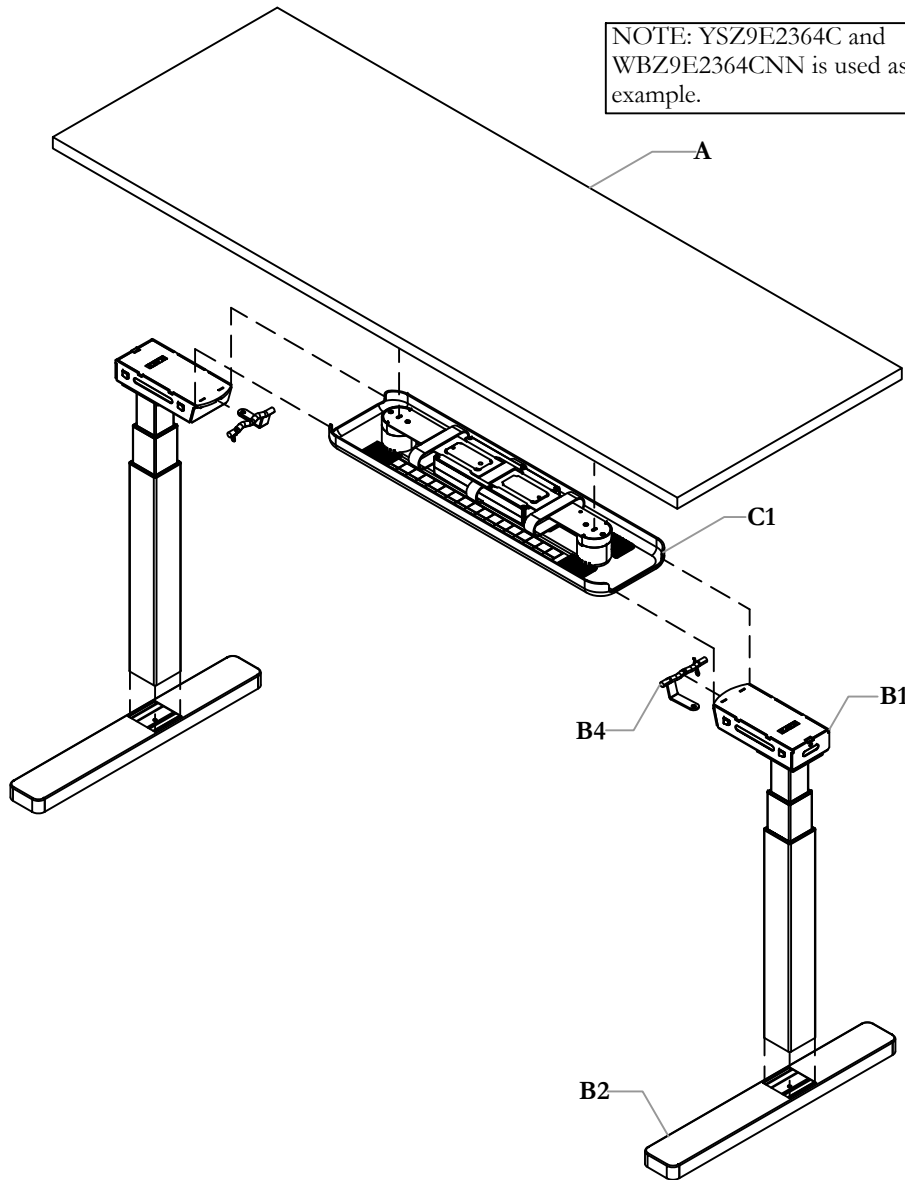

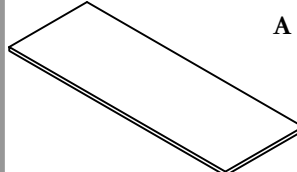

NOTE: Refer to DIS_512 for complete Guide on Upstage Post Leg.

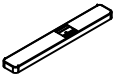
hiSpace Rectangular Height-Adj. Worksurface w/ Connection Kit (WBZ),
hiSpace Quick Connect Height-Adj. Freestanding Table (YSZ)

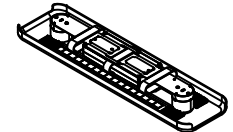
NOTE: YSZ9E2364C and WBZ9E2364CNN is used as an example.

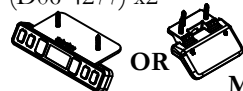

Part and Product Identification

	 <p>A - Rectangular HA Worksurface w/ Connection Kit for- hiSpace (WBZ) (C07-7246) x1</p>	
<p>B - hiSpace Quick Connect Mechanism (YSZ) x1</p>	 <p>B1 - HiSpace Bifma Range Leg (N09-9282) x2</p>  <p>B3 - M6x14-SHCS (E04-0096) x8</p>	 <p>B2 - HiSpace Table Foot Assm. (N09-5784) x2</p>  <p>B4 - Cam Handle w/ Cotter Pin. (N09-9814) x2</p>
<p>C - Cable Organizer w/ Felt Cover hiSpace (N09-9975) x1</p>	 <p>C1 - Large Cable Organizer w/ Felt Cover (N09-8069S) x1</p>  <p>C3 - Right Angle Connector 1m Lg. (D06-4277) x2</p>  <p>C5 - Keypad, hiSpace Table (D06-4276) x1 OR Kaidi hiSpace Toggle Switch (N01-7336)x1 NOTE: Mounting Screws are included</p>	 <p>C2 - #10x0.875" Screw (E07-0077) x2</p>  <p>C4 - 3m Power Cord (D06-4136) x1</p>
<p>D - Kaidi Hardware Kit, hiSpace (X05-0548) x1</p>	 <p>D1 - Cable Clamp, BLK (B02-0558) x2</p>  <p>D2 - #6 x 5/8" Flat Quad WD Screw. (E04-0090) x2</p>	

ATTACH LEGS TO WORKSURFACE

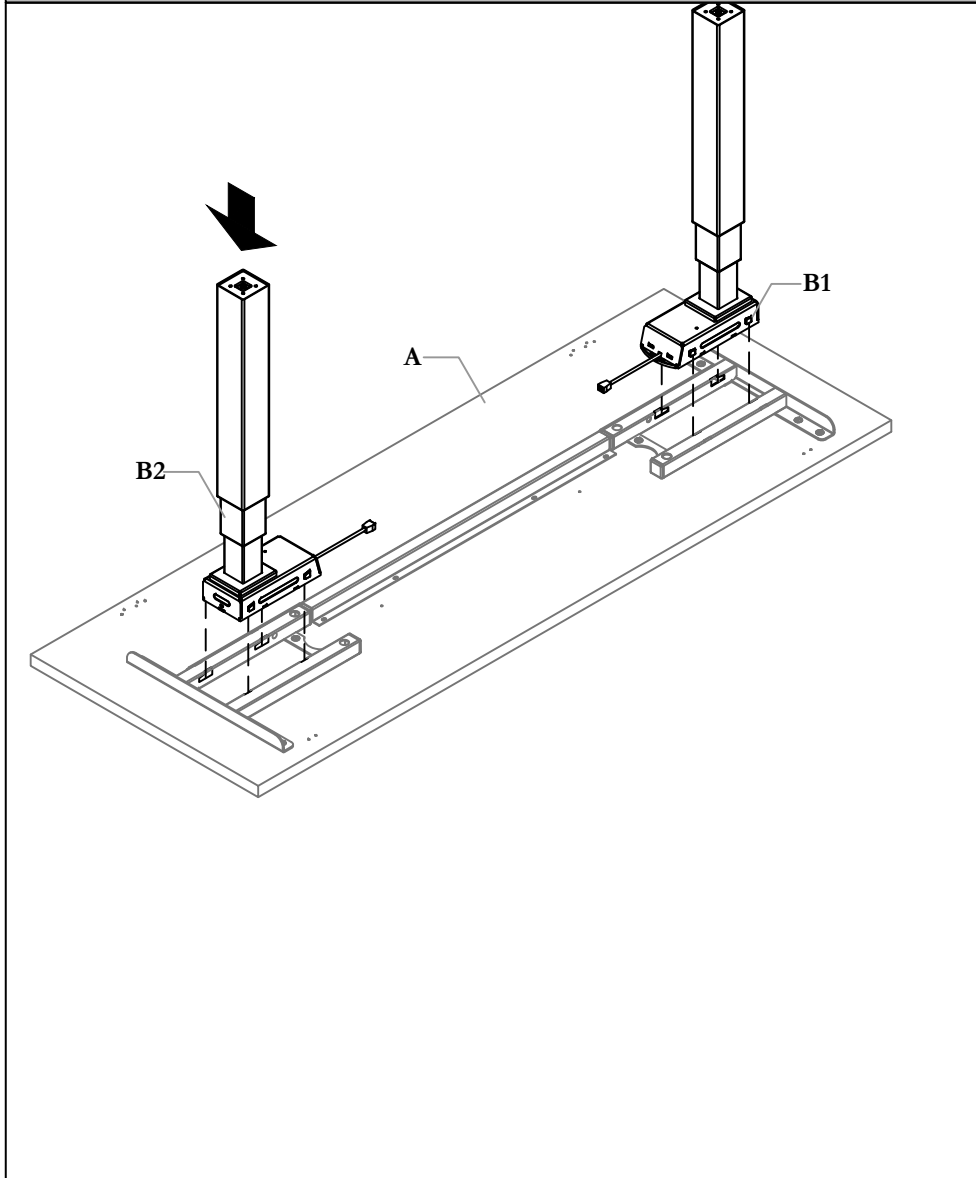

STEP 1: Attach legs (B1) to Worksurface (A) as shown above.

SECURE LEGS TO WORKSURFACE

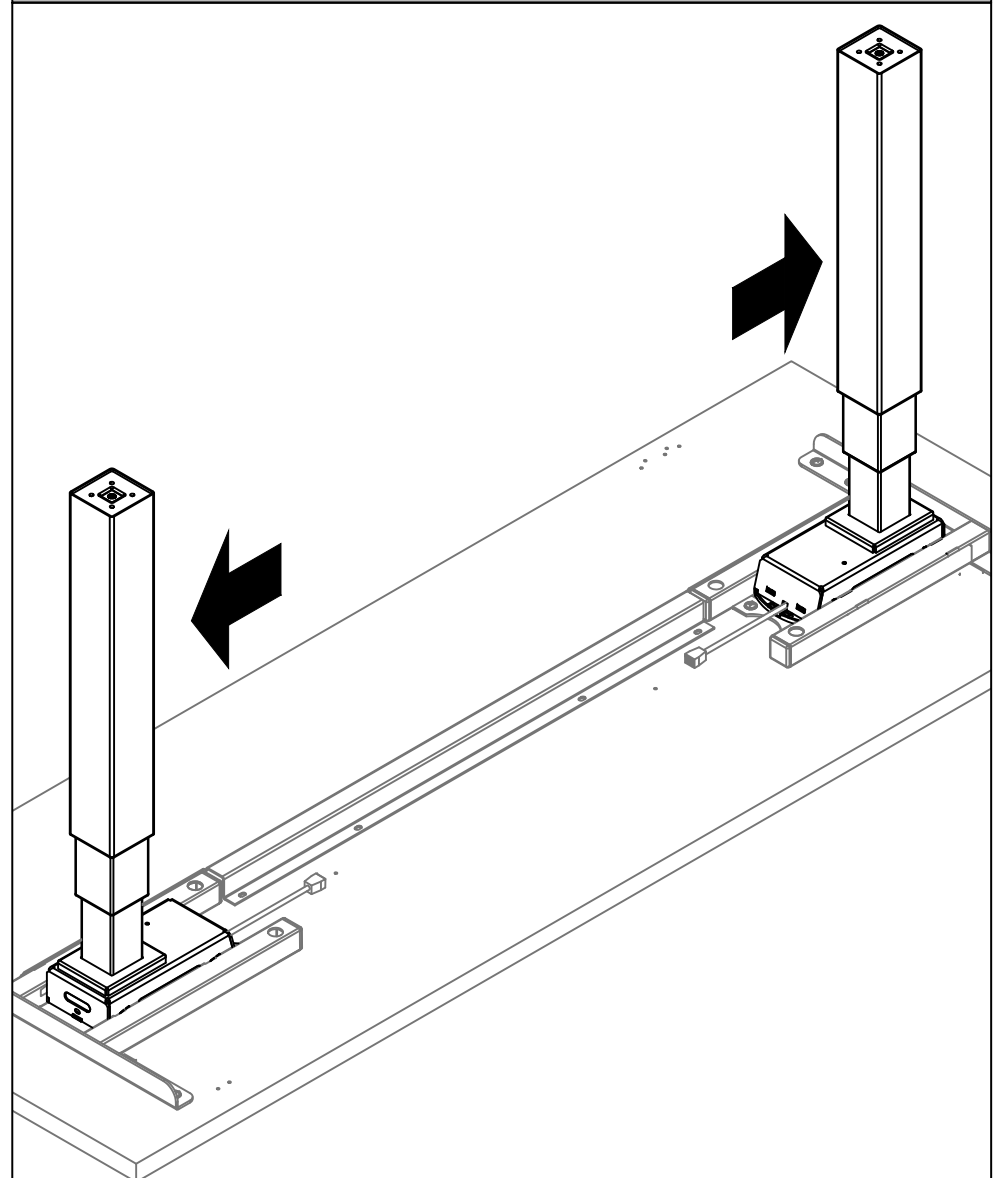

STEP 2: Push Legs to Outer side of the Worksurface.

SECURE LEGS TO BRACKETS - 1

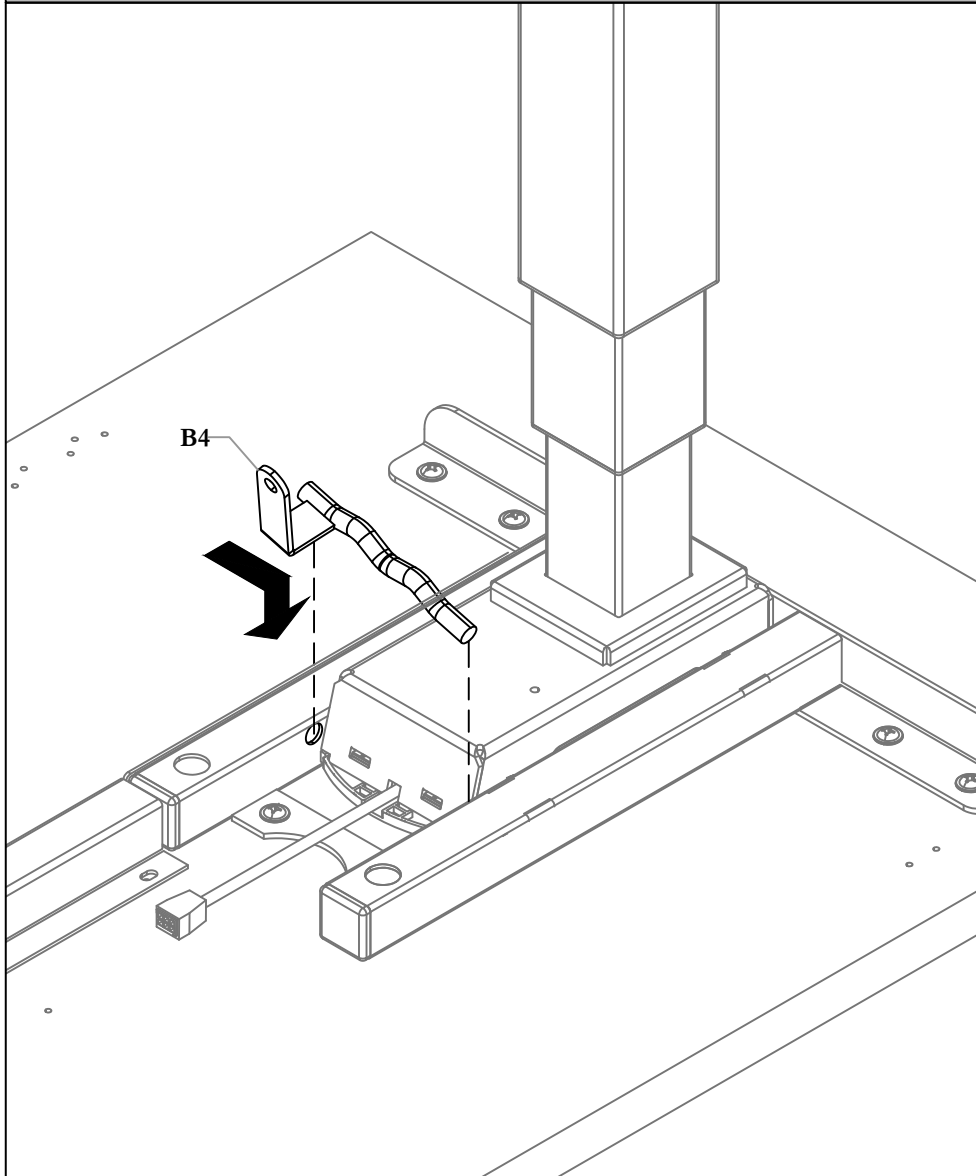

STEP 3: Install Cam Handle (B4) as shown above and Make sure its Locked in place.

SECURE LEGS TO BRACKETS - 2

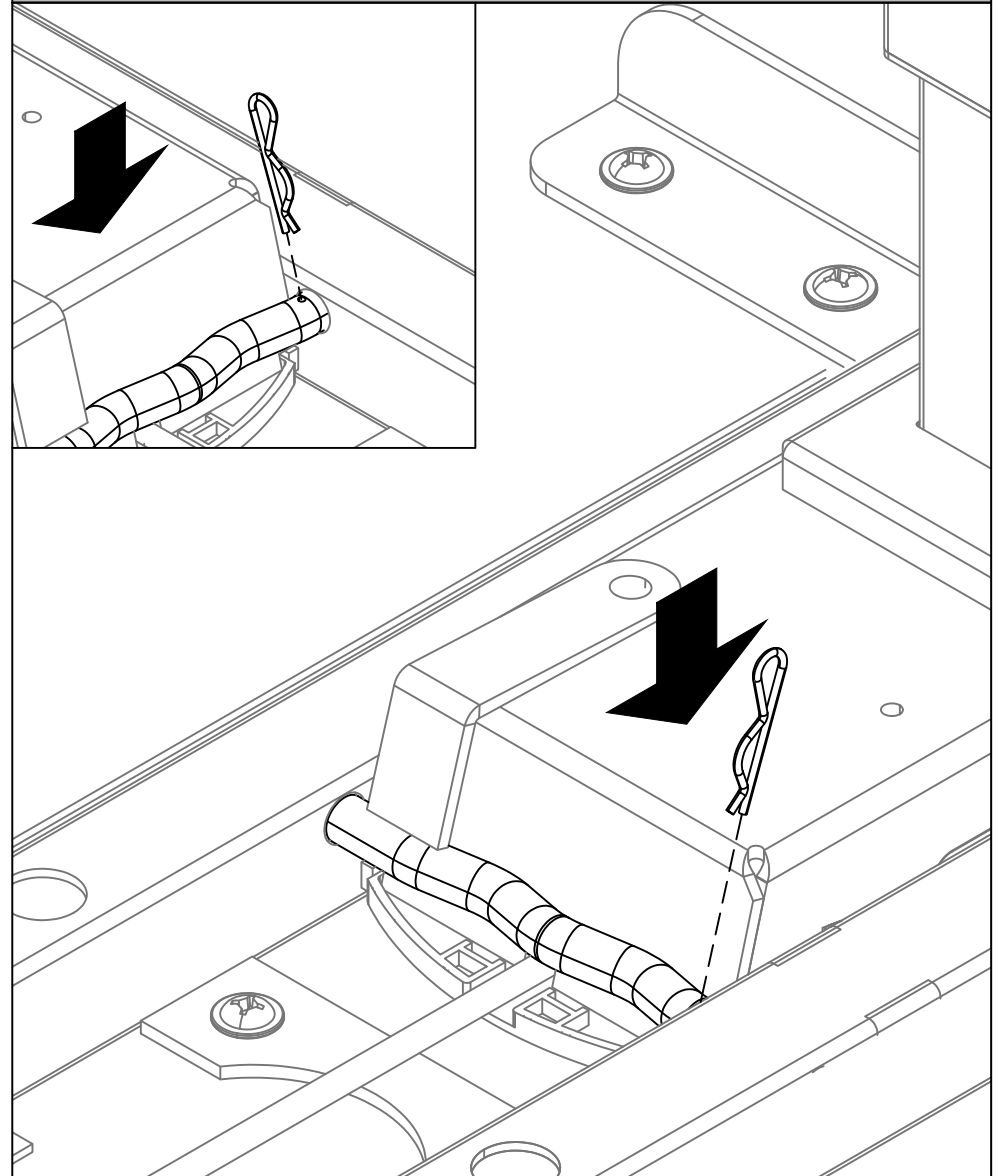

STEP 4: Insert Pin and lock the Cam handle as shown above.

ATTACH FEET TO LEGS

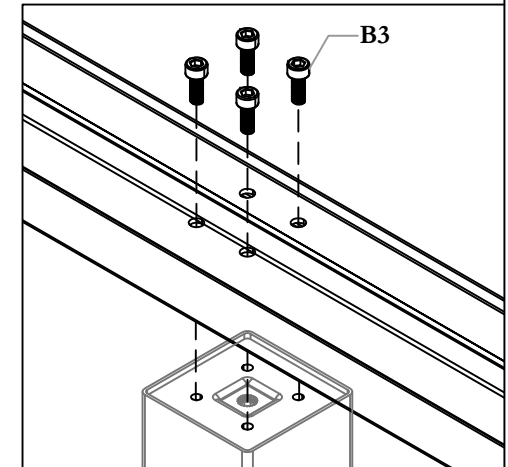
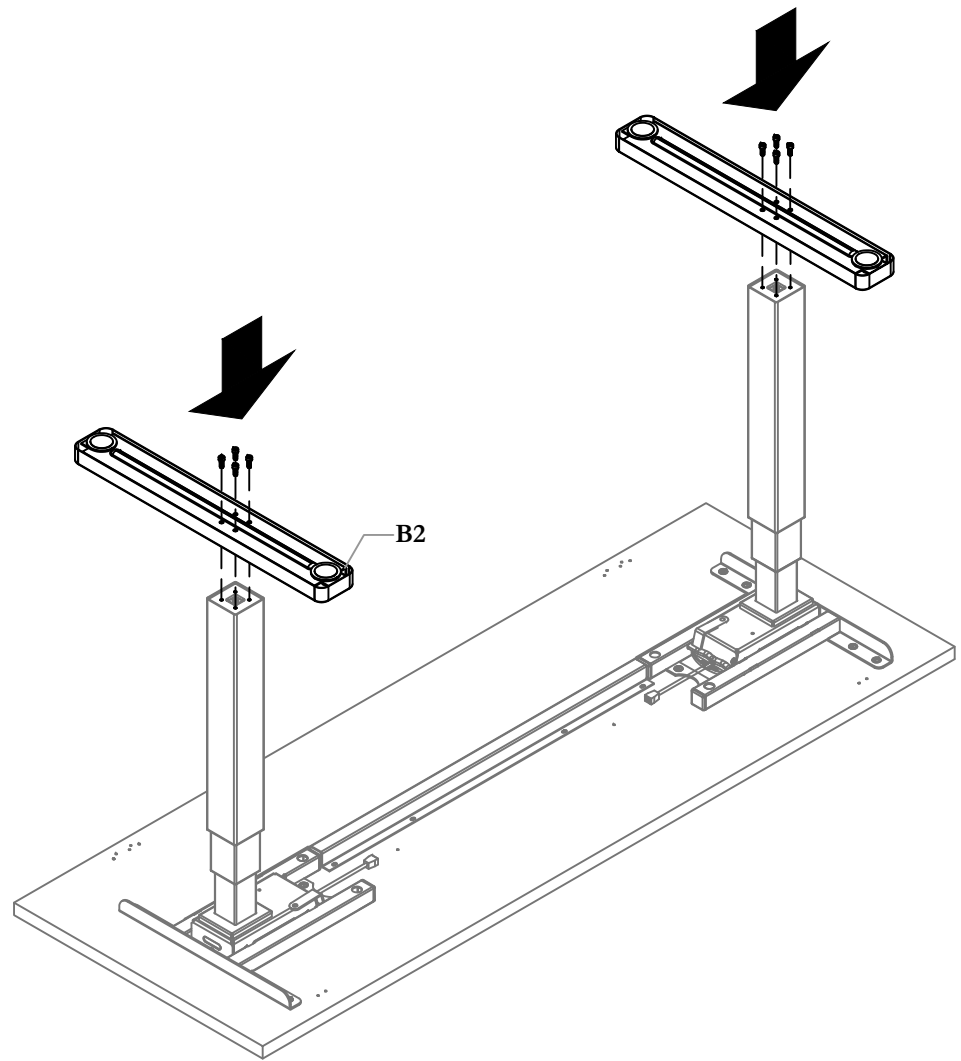

STEP 5: Attach Feet to legs (B2) as shown above with screws provided (B3).

REMOVE FELT COVER - 1

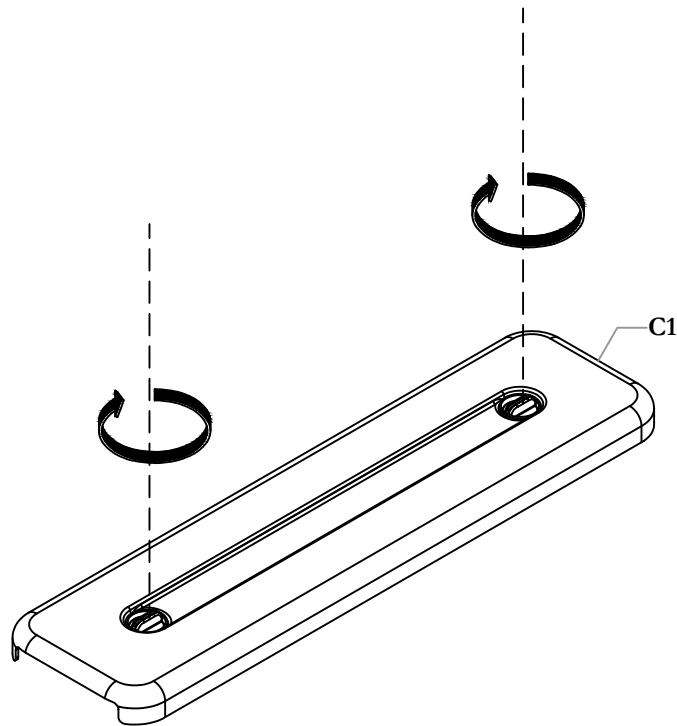

STEP 6: Unscrew lock on Cable Organizer Felt Cover (C1) as shown above.

REMOVE FELT COVER - 2

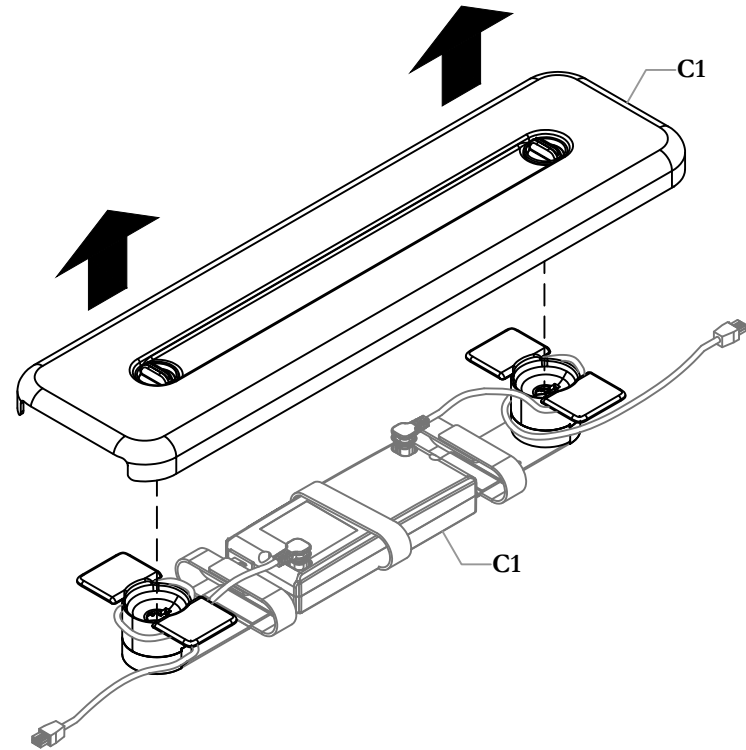

STEP 7: Remove Felt Cover as shown above.

WIRE MANAGEMENT

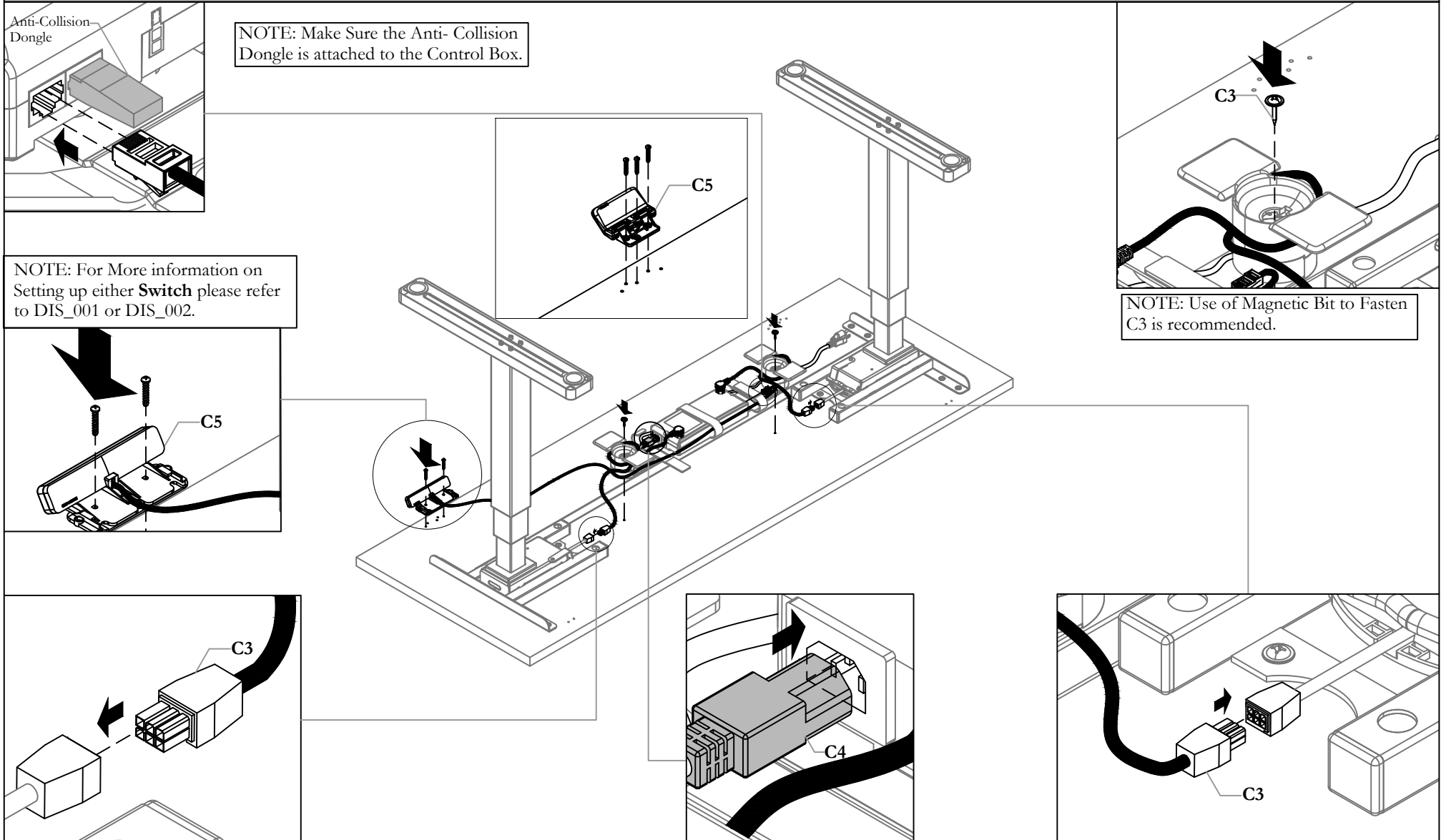

STEP 8: Plug Wires and Switch (instructions are the same for both switches) with screws as shown above. Attach Felt Cover Base to the worksurface. Make the connections & Wrap around wires around the Stem. Ensure that the switch cable has slack and does not affect the toggle movement.

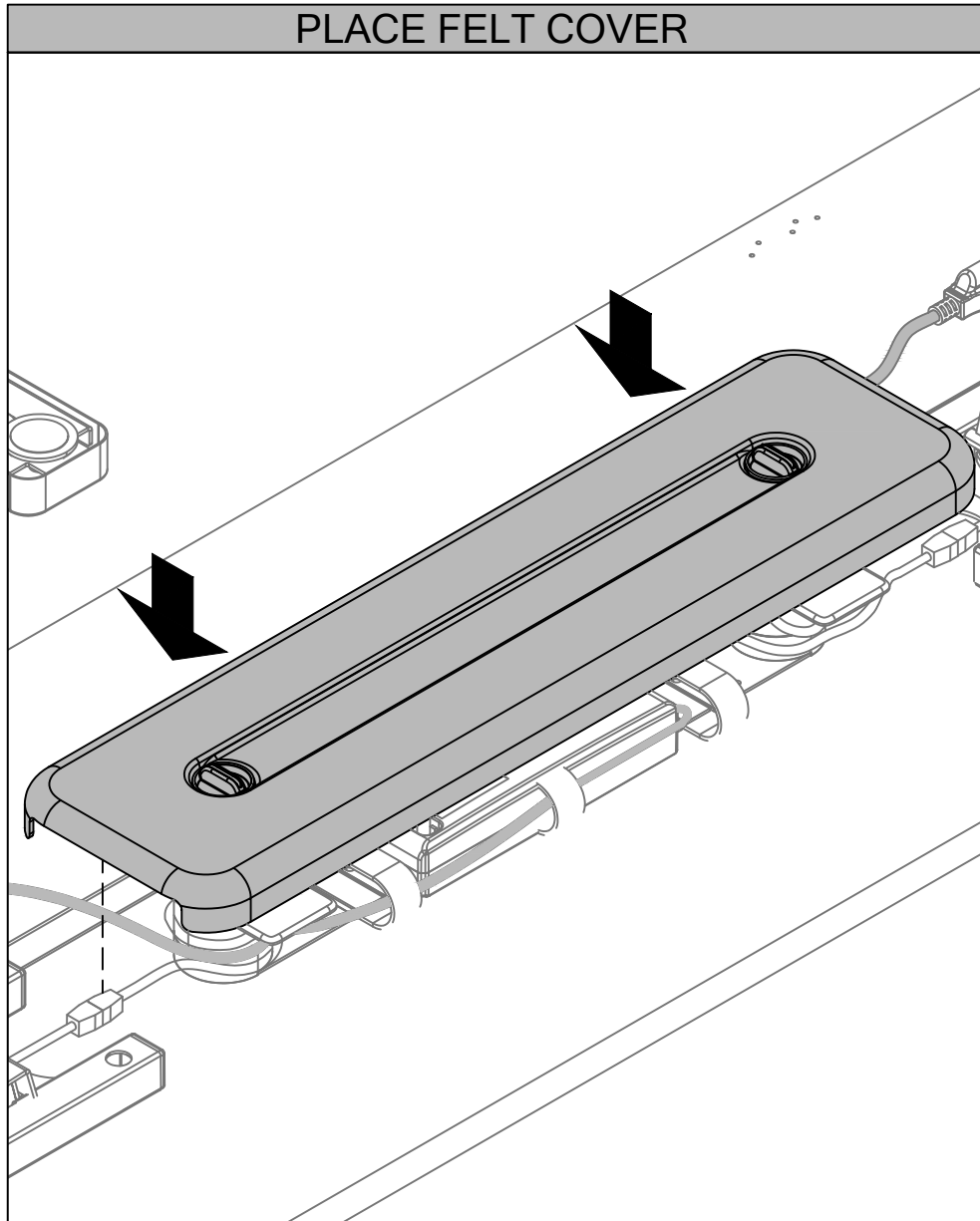

STEP 9: Place back the Felt Cover.

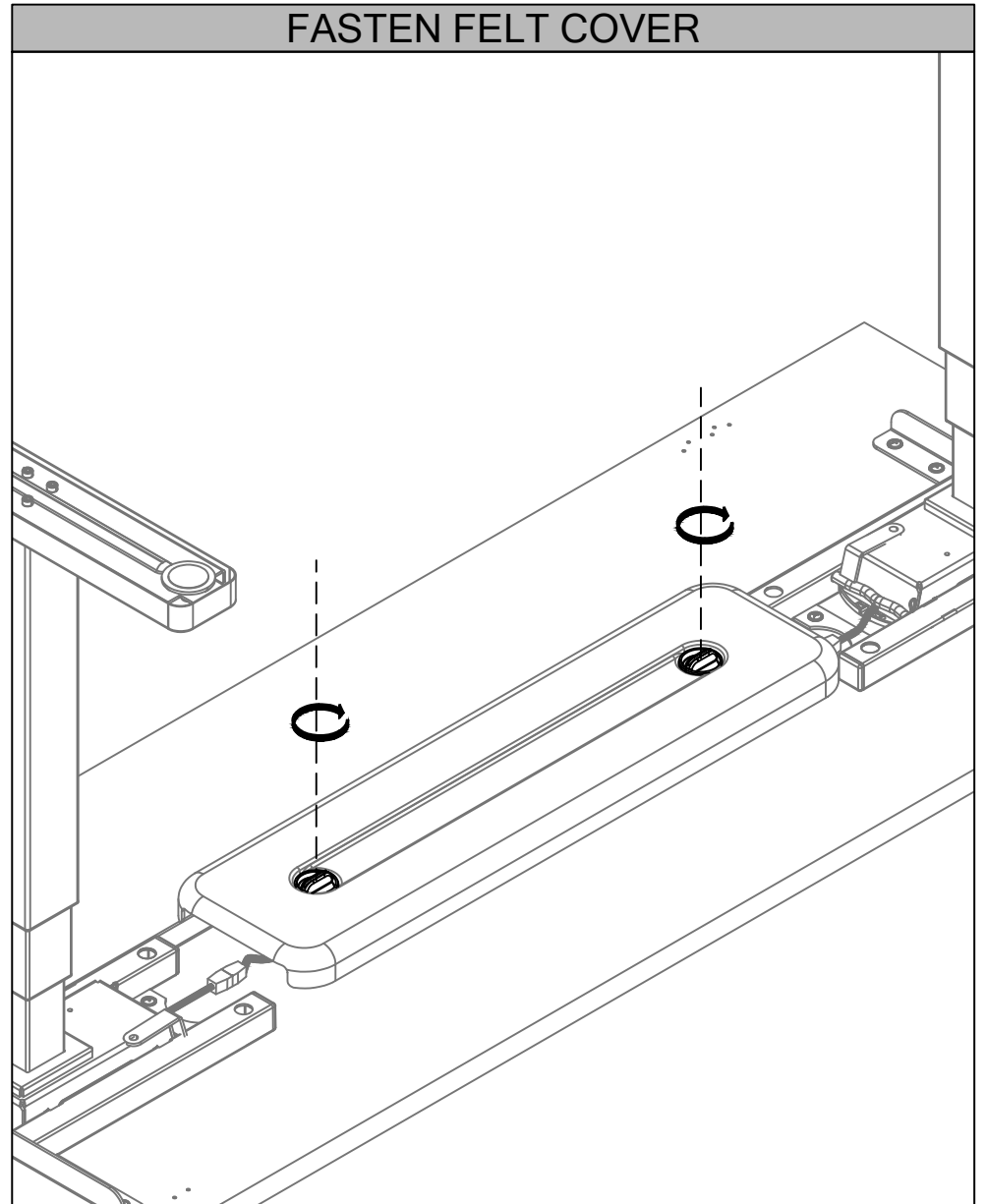

STEP 10: Fasten Felt Cover.

PLACE CABLE CLAMP

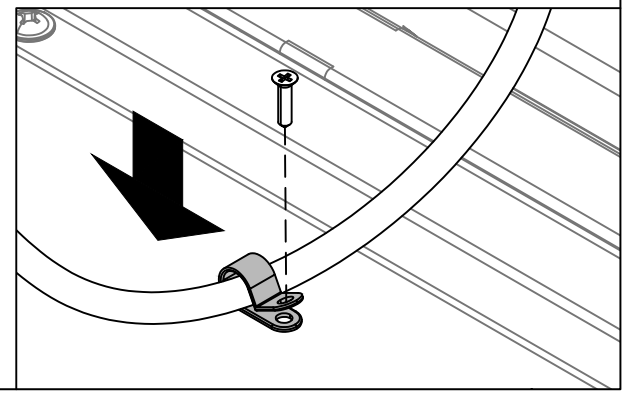
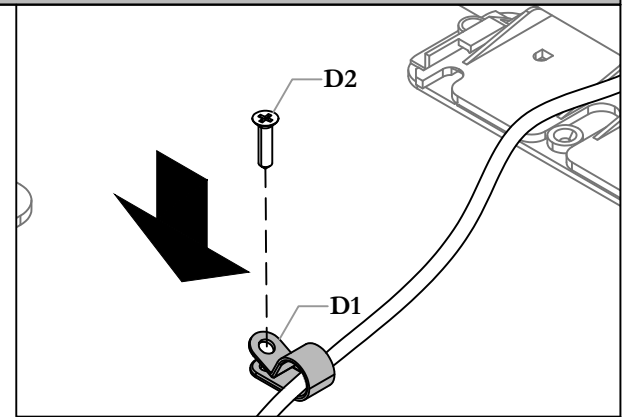
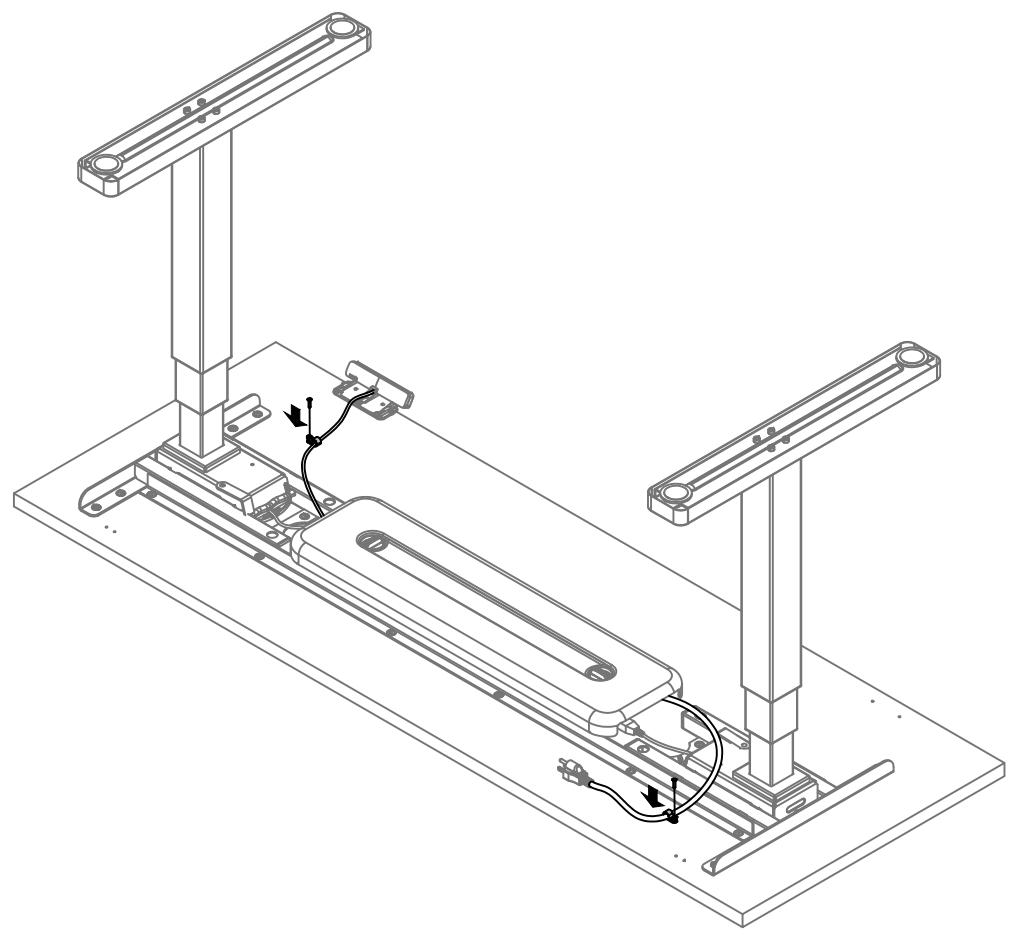

STEP 11: Place cable Clamps (D1) as shown above.

SETTING UP SWITCH (OPTIONAL)

NOTE: For More information on Setting up **hiSpace Table Keypad Switch**. Please refer too DIS_001.

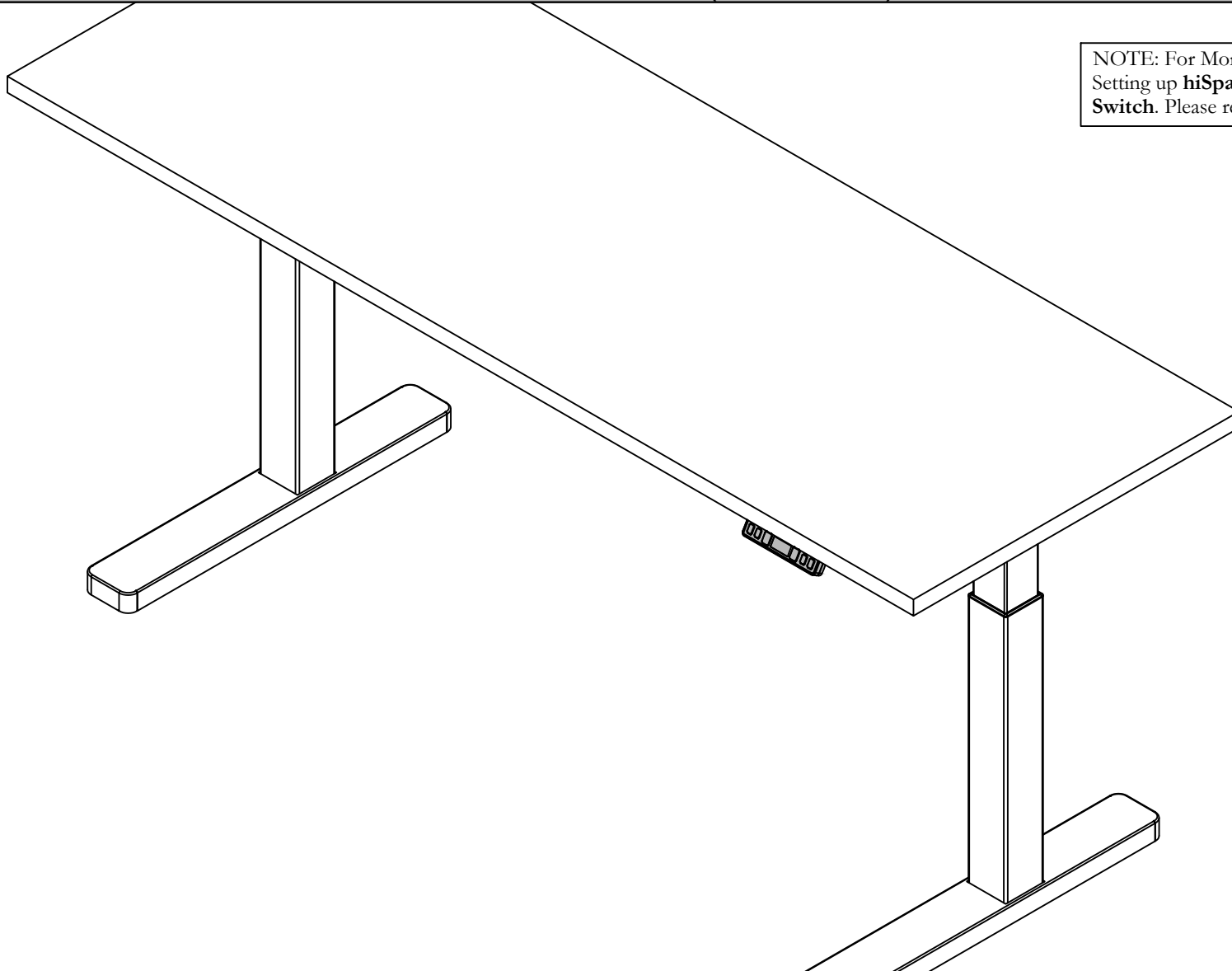

STEP 10 (Optional): For More information on Setting up **hiSpace Table Keypad Switch**. Please refer to DIS_001.

120 Hub HA Worksurface For hiSpace Quick Connect with District Power Spine (WBT),
hiSpace 120 Height-Adjustable Freestanding Table (YST)

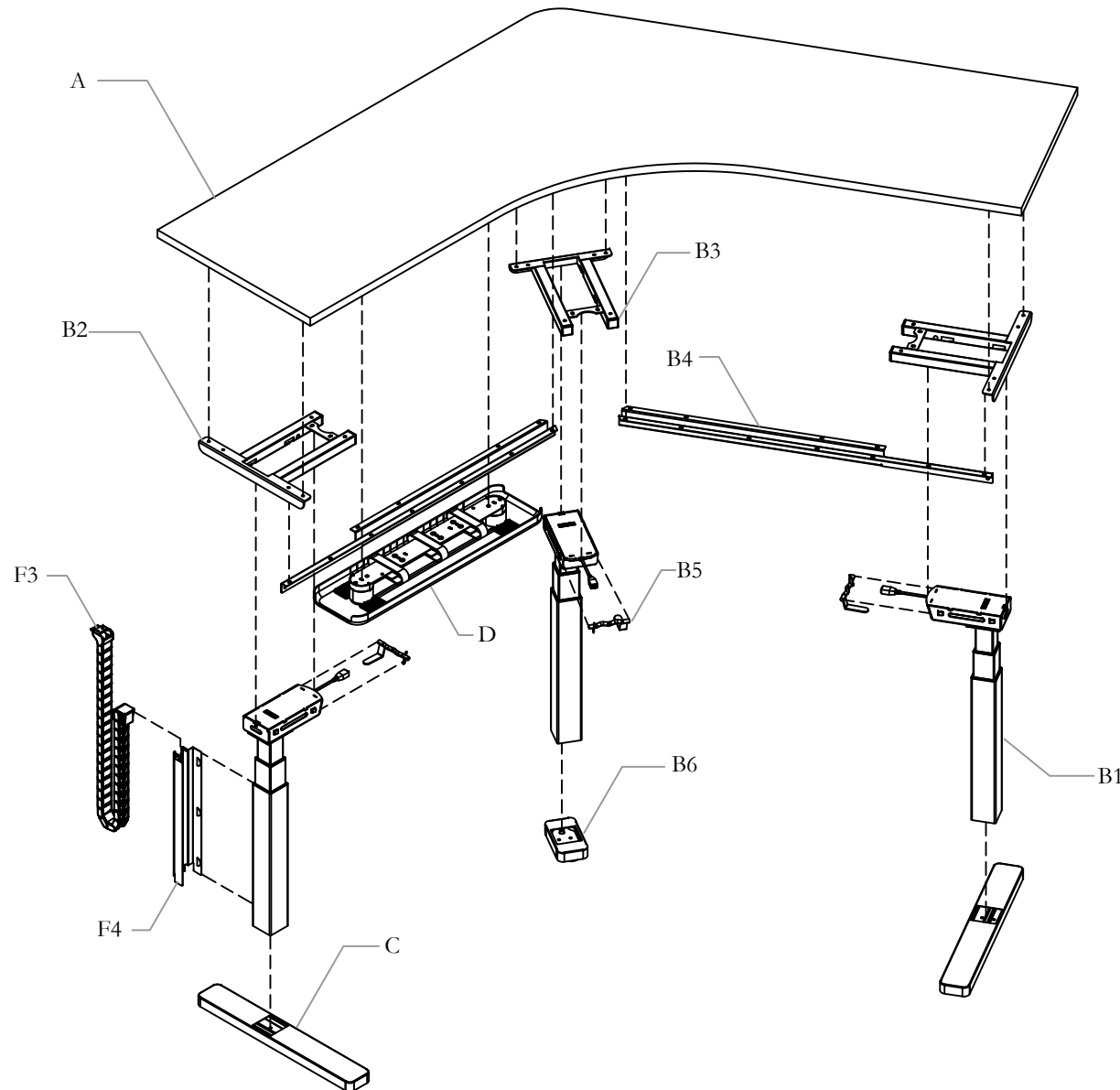

WARNING!

Installers must not perform any electrical work while power is on. Care should be taken to test and confirm power is off prior to beginning any assembly and/or disassembly. Do not connect to power source until installation is complete.

Connection to the building power source must be performed by a licensed electrician. Failure to follow these instructions poses significant risk of electrical shock, injury and damage.

Only licensed electricians are authorized to make electrical connections in accordance with applicable codes and regulations.

For Teknion Base Feed harnesses, any replacement of the fitting on the hardwired end of the liquidtight whip must be done by a licensed electrician using only fittings approved for the type of liquidtight conduit used on the base feed harness.

Failure to exactly follow these instructions renders Teknion's warranty and safety certifications null and void.

Section: HEIGHT ADJUSTABLE TABLES

Description: 120 HA TABLE - QUICK CONNECT

Part and Product Identification



A - 120 Hub HA Worksurface for hiSpace Quick Connect with District Power Spine (WBT) x1

B - hiSpace 120 Height-Adjustable Freestanding Table (YST) x1

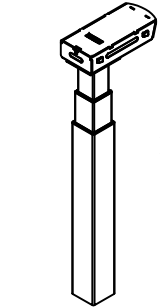

B1 - Kaidi QI Bifma Range Leg, High Capacity (N01-8446) x3

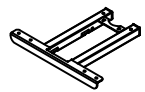

B2 - Leg Mount Bracket QI hiSpace (N09-9873) x2

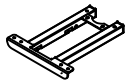

B3 - Leg Mount Bracket Short QI hiSpace (N09-4900) x1

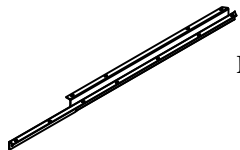

B4 - Stiffener (A16-11207L) x1 (A16-11207R) x1



B5 - Cam Handle hiSpace2 (N09-9814) x3



B6 - Foot 6", hiSpace (N09-9458X) x1

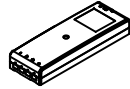

B7 - Control Box for 3 Leg BIFMA System with Anti-Collision (N09-9457) x1



B8 - 3M US/Canada Power Cord (D06-4136) x1

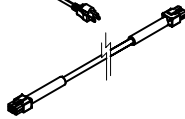

B9 - hiSpace Motor Cable (N09-9455\10) x 2 (N09-9455\25) x 1



B14 - M6x16, SHCS (E04-0096) x12



B15 - #10 x 0.875" LG Screw (E07-0077) x Varies

YS Feet (Pair), hiSpace Table (N09-5784\24) x1

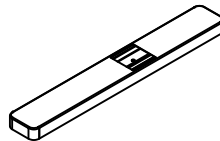

C - Foot Assembly, hiSpace Table (N09-5790\24) x2

D - Large Cable Organizer With Felt Cover (N09-8069S) x1

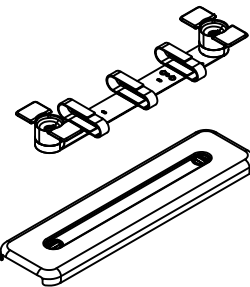

D1 - Wire Manager Mounting Bracket (A16-6737) x 1

D2 - Wire Manger Cover (B07-0239) x 1



D3 - M5x20 Philips Screw (E07-0203) x 4



D4 - M5x0.8, 12mm Philips Screw (E01-1106) x2

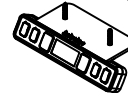

B10 - Keypad, hiSpace Table (D06-4276) x1

OR

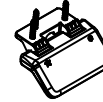

Kaidi hiSpace Toggle Switch (N01-7336)x1

*Mounting Screws are included



B11 - #8x1" Wood Screw (E01-1415) x 2



B12 - #6 x 5/8" Quad WD Screw (E01-1417) x 10



B13 - Cable Clamp 3/8, BLK (B02-0558) x 10

E - Complements Dual Plastic Cable Management Tray (YEYS02) x1

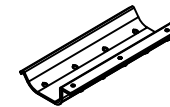

E1 - Wire Manager (B02-0746) x2



E2 - #12x3/4 Wood Screw (E04-0087) x6

F - Vertical Wire Carrier - hiSpace Workstation (N01-5114\16\34) x1



F1 - Vertical Wire Carrier Worksurface Connector (B02-0844) x1



F2 - Vertical Wire Carrier Leg Connector (B02-0845) x1



F3 - Vertical Wire Carrier Assembly (N01-6034\34) x1



F5 - #12x7/8" WD Screw (E04-0087) x2



F4 - Vertical Cover & Pad Assembly (N09-8474\16) x1

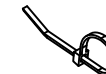

F6 - Cable Tie (B02-0545) x1

ATTACH BRACKETS TO WORKSURFACE

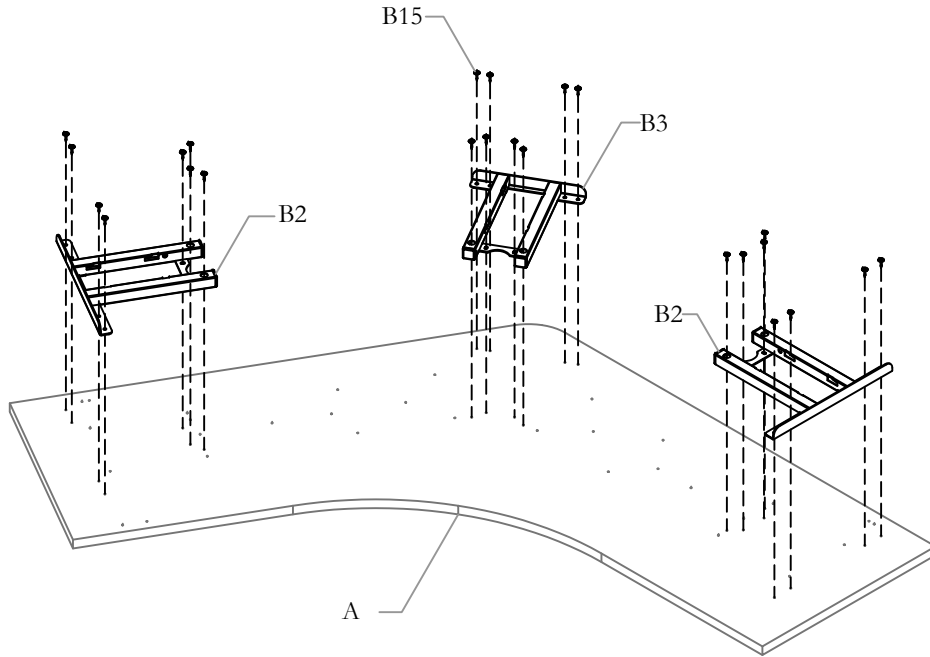

NOTE: Worksurface upside down

NOTE: Do not over tighten

STEP 1: Attach Leg Mount Brackets (B2&B3) to the Worksurface (A) as shown using provided Screws (B15).

ATTACH REINFORCEMENT BARS

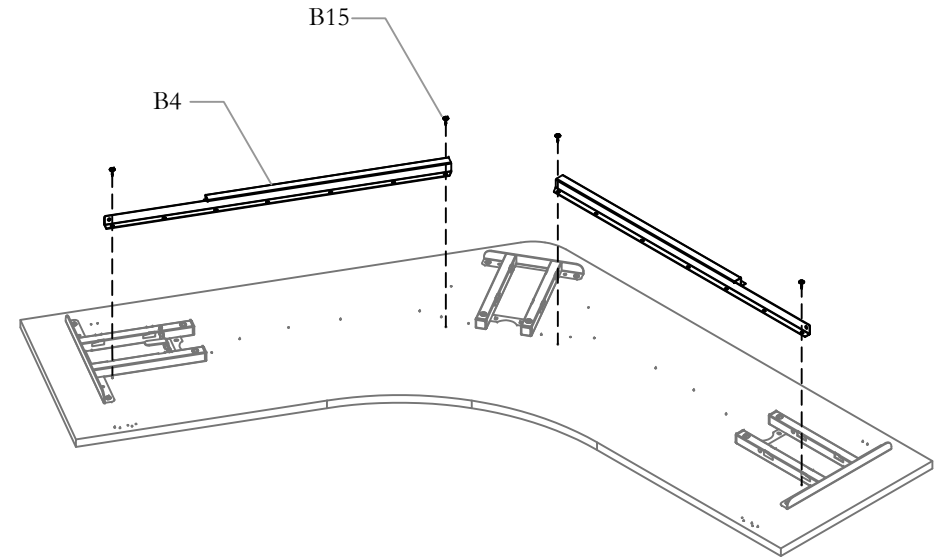

NOTE: Do not over tighten

STEP 2: Attach the Reinforcement Bars (B4) to Worksurface as shown and secure with provided Screws (B15).

ATTACH LEGS TO BRACKETS

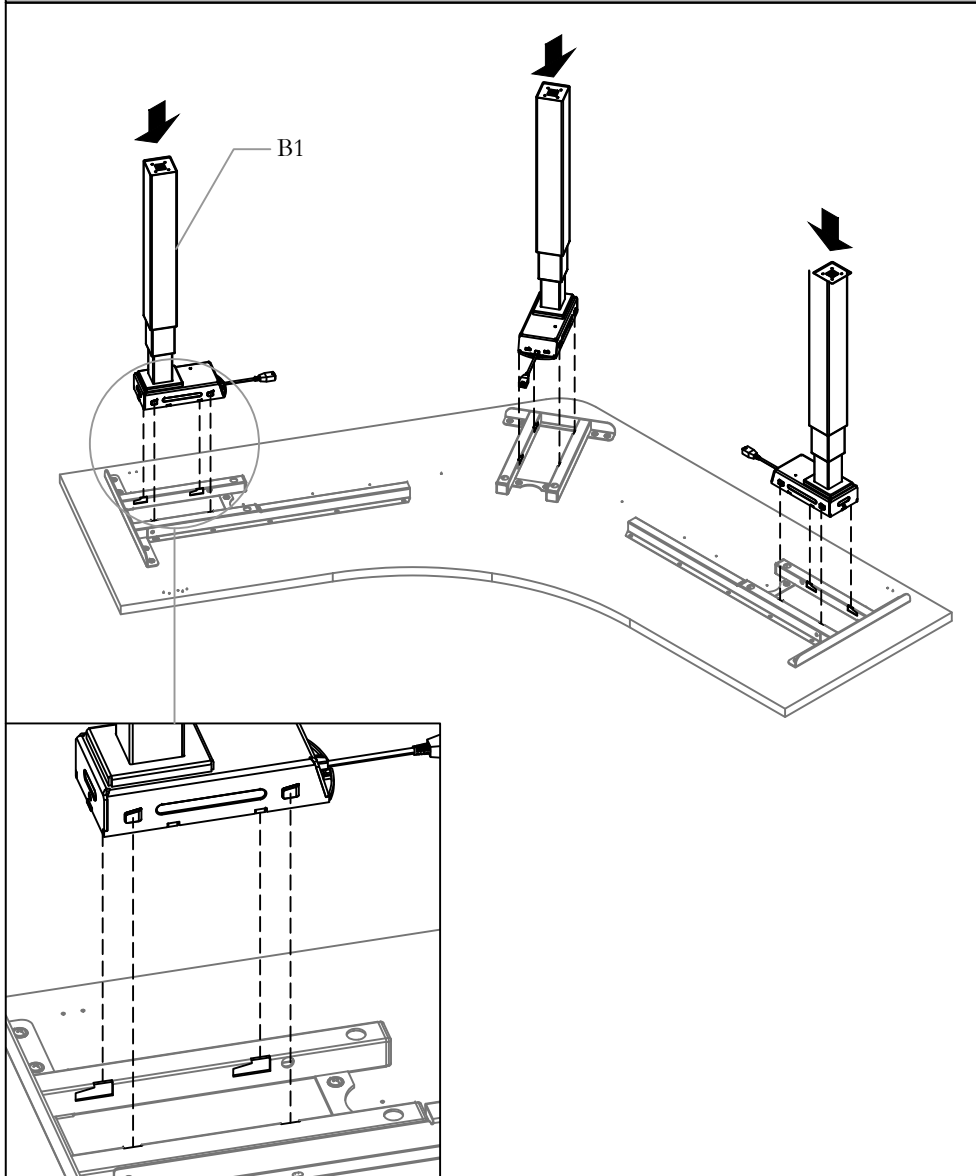

STEP 3: Attach Legs (B1) to Brackets by lining up with holes as shown.

SECURE LEGS TO BRACKET - 1

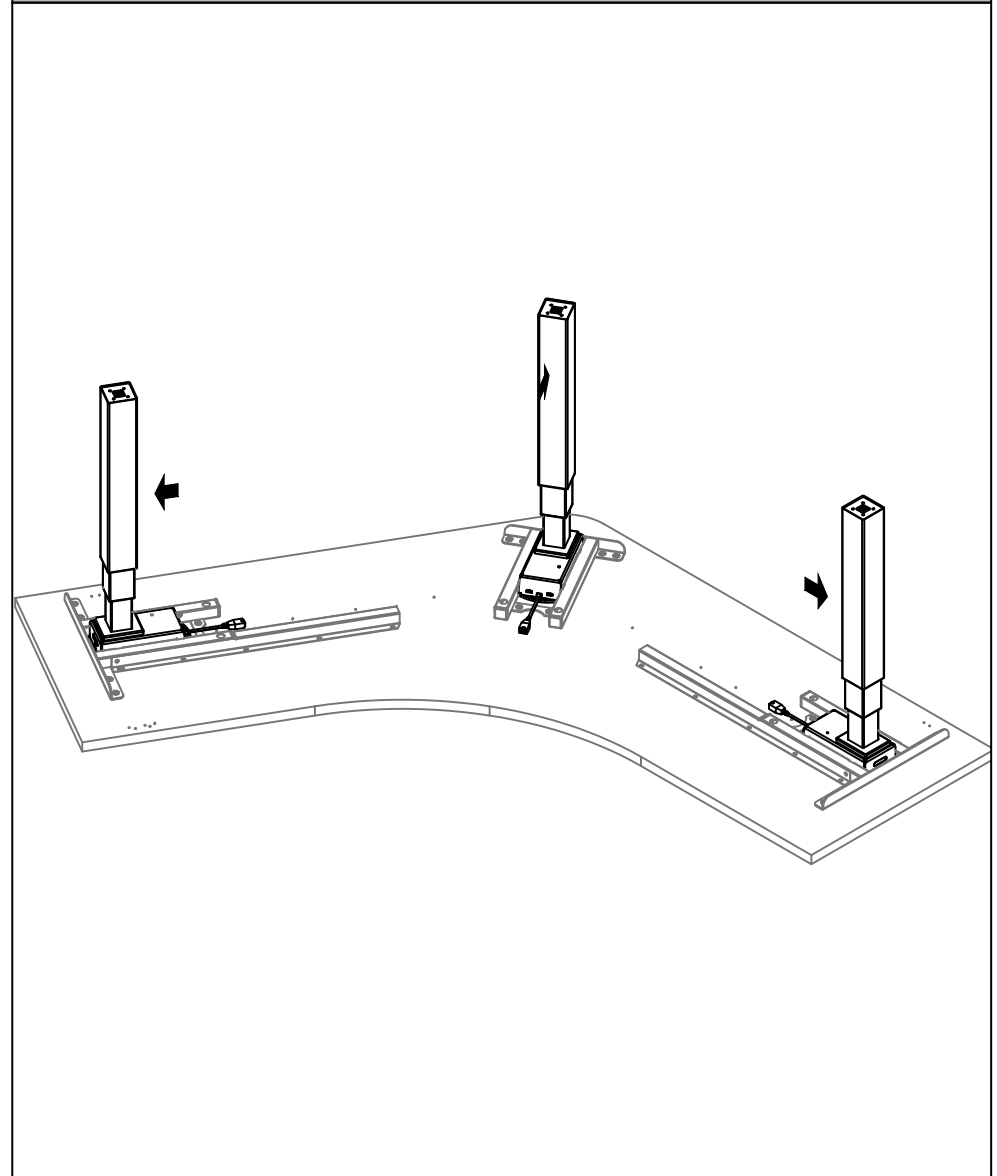

STEP 4: Push Legs towards the outer side of the Worksurface.

SECURE LEGS TO BRACKET - 2

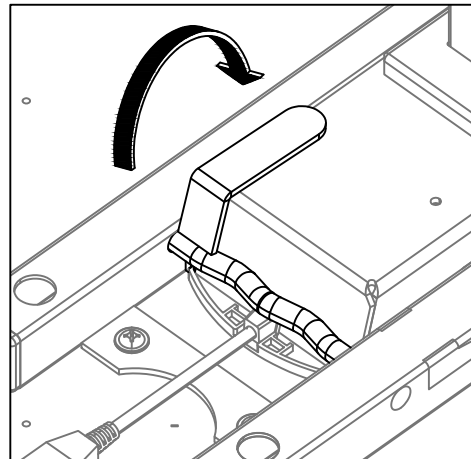
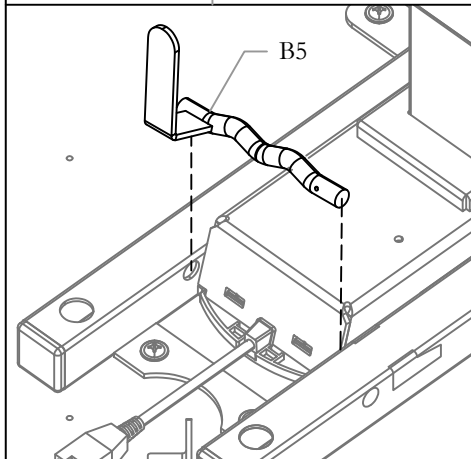
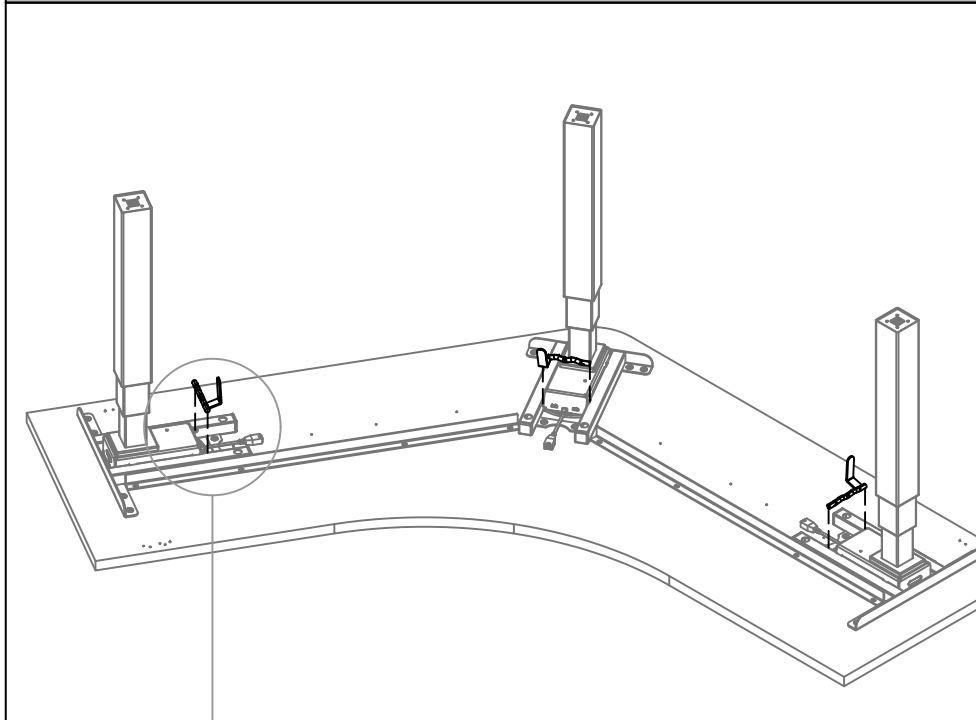

STEP 5: Install the Cam Handles (B5) into the Brackets turning towards Leg to lock

SECURE LEGS TO BRACKET - 3

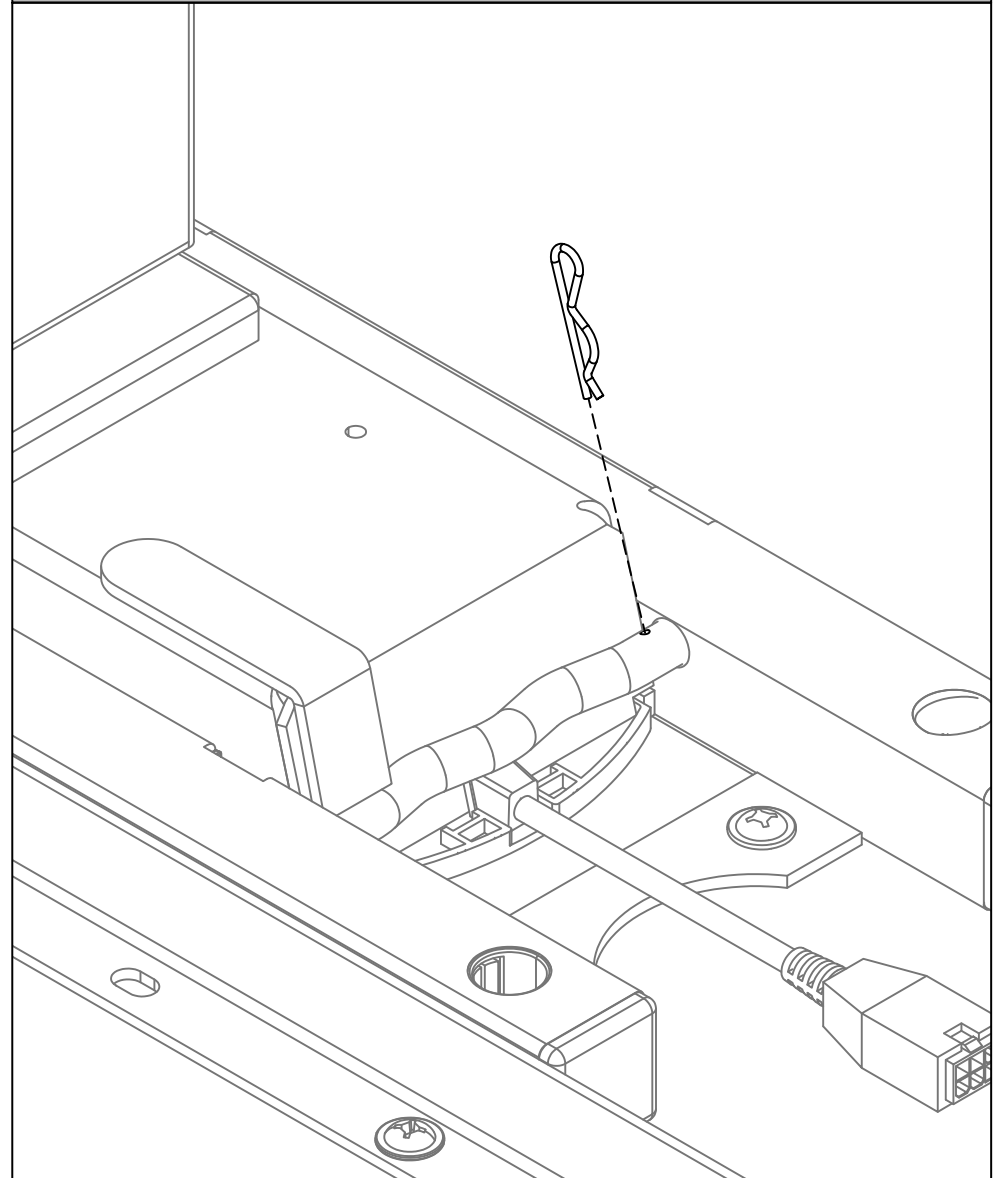

STEP 6: Insert Pin as shown to lock Cam Handle.

ATTACH FEET TO LEGS

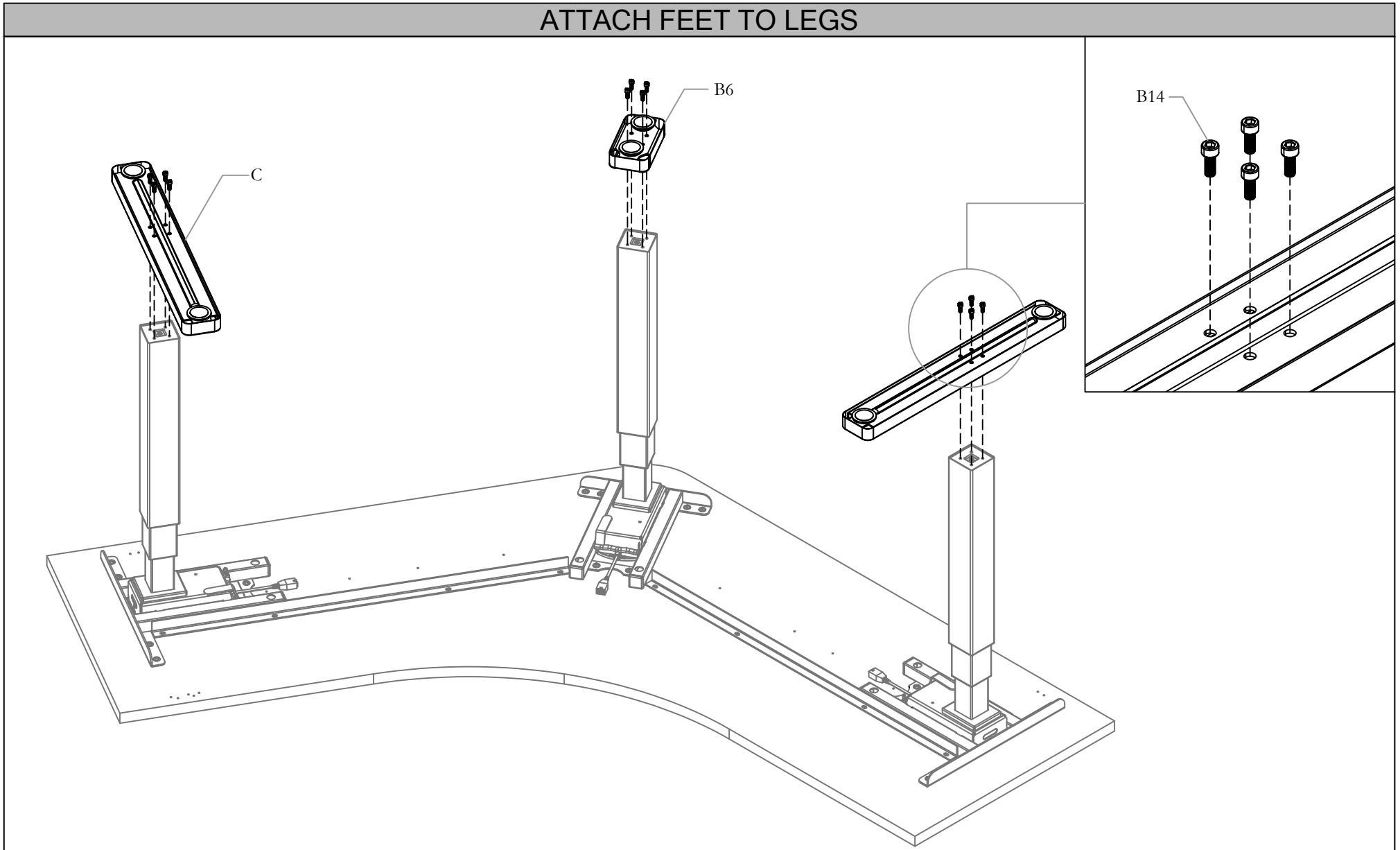

STEP 7: Attach feet to legs using provided Screws (B14) as shown.

DISASSEMBLE FELT COVER

NOTE: Only necessary if Cable Organizer with Felt Cover specified.

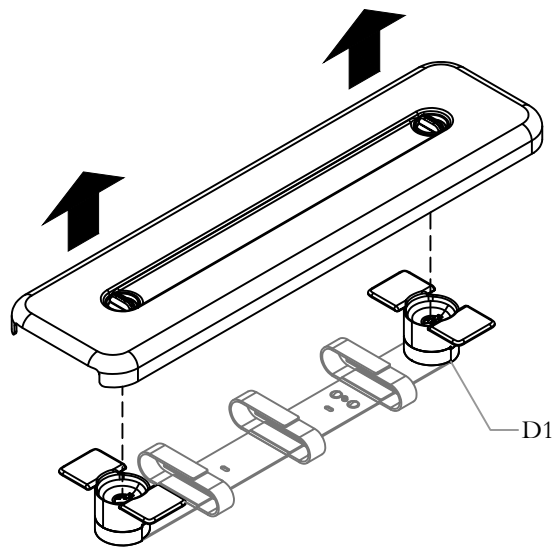
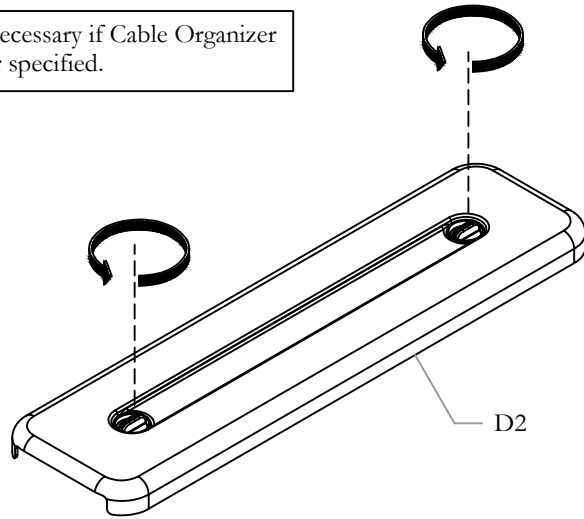

STEP 8: Disassemble Felt Cover as shown.

ATTACH MOUNTING BRACKET

NOTE: Only necessary if Cable Organizer with Felt Cover specified.

NOTE: Do not over tighten

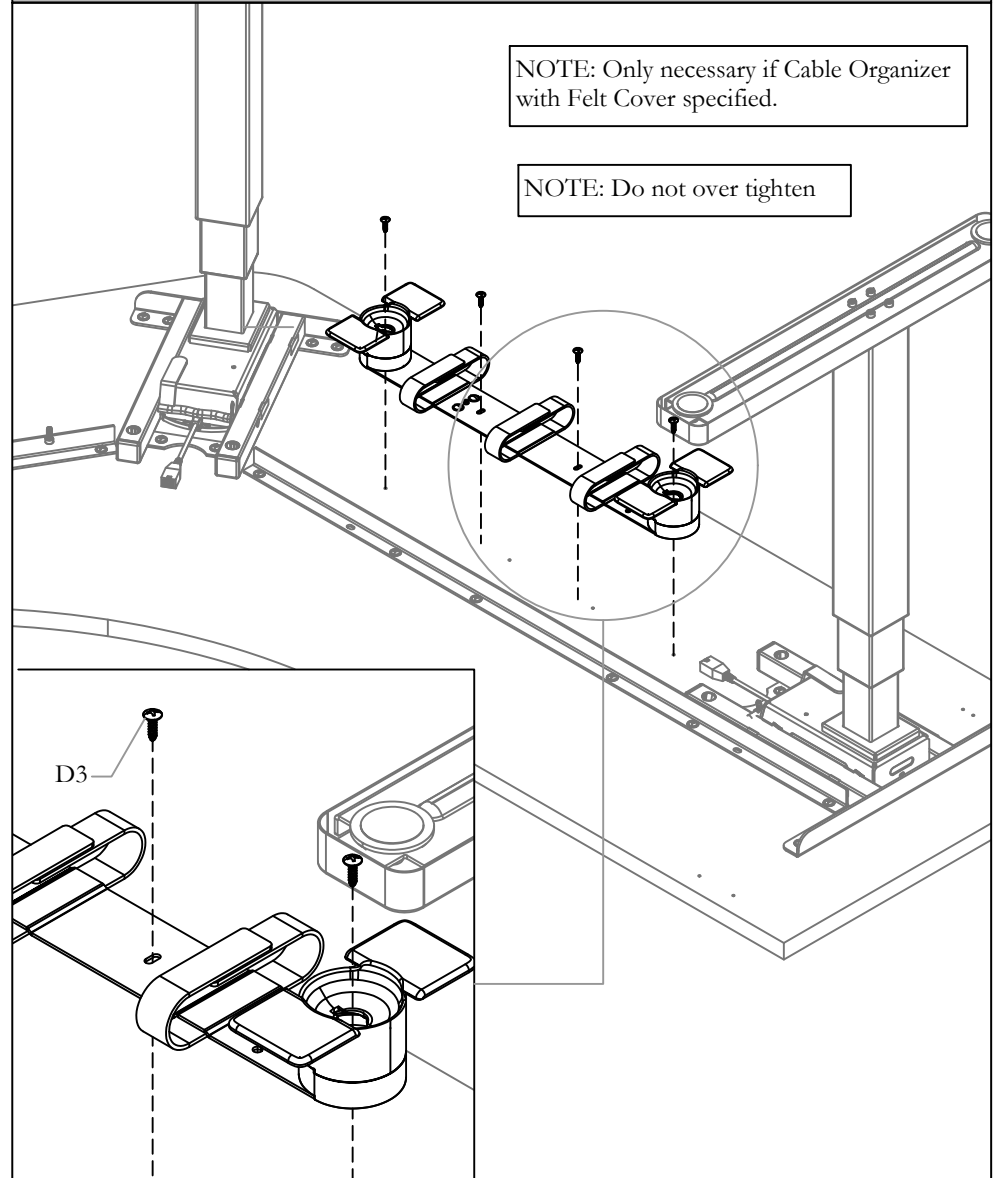

STEP 9: Attach Mounting Bracket (D1) to Worksurface using provided Screws (D3).

ATTACH AND SECURE CONTROL BOX

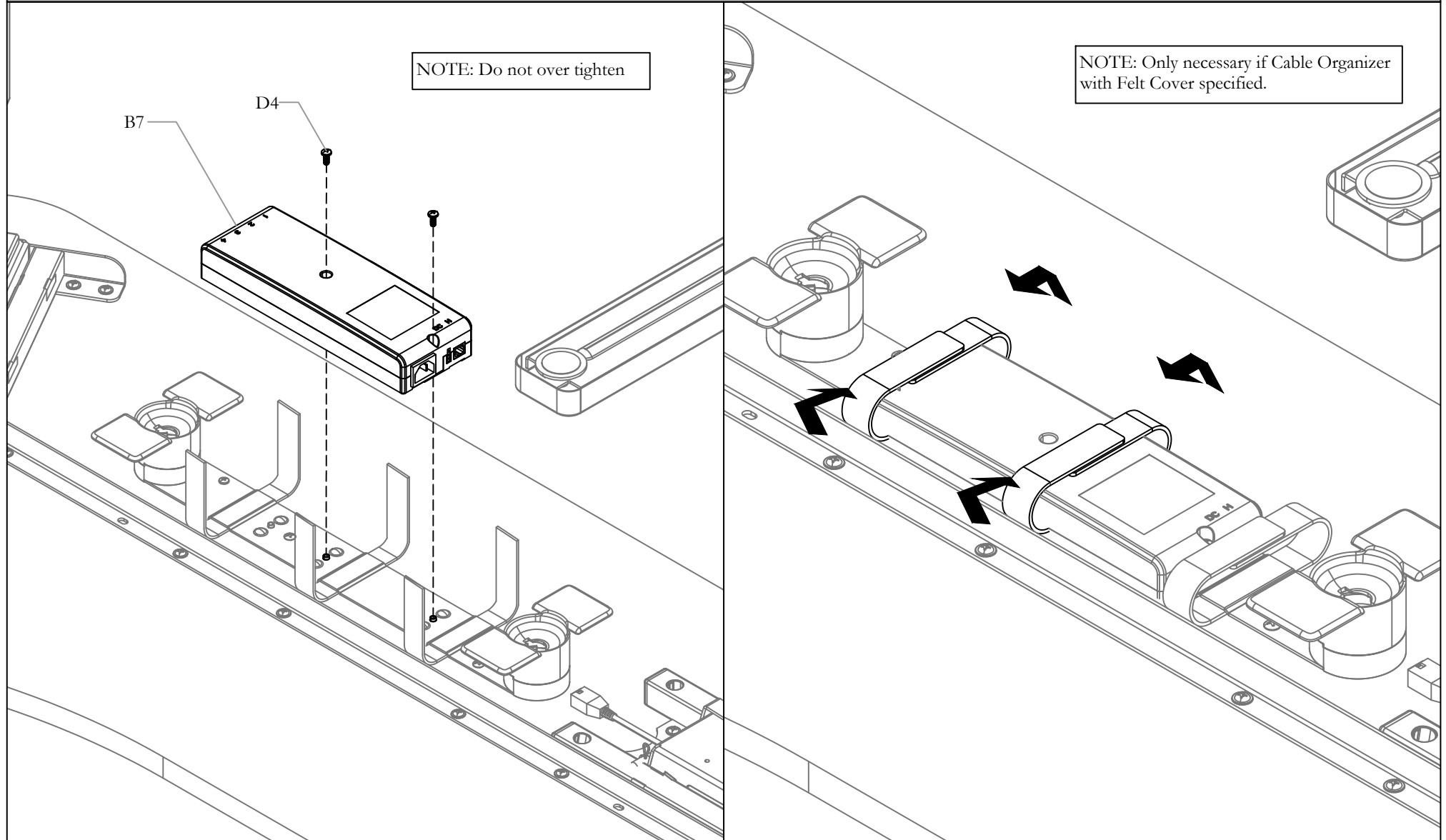

STEP 10a: Attach the Control Box (B7) to the Mounting Bracket using provided screws (D4) and secure with straps.

WARNING! Installers must not perform any electrical work while power is on. Care should be taken to test and confirm power is off prior to beginning any assembly and/or disassembly. Do not connect to power source until installation is complete. Connection to the building power source must be performed by a licensed electrician. Failure to follow these instructions poses significant risk of electrical shock, injury and damage. Only licensed electricians are authorized to make electrical connections in accordance with applicable codes and regulations.

ATTACH CONTROL BOX

NOTE: If Cable Organizer with Felt Cover is not specified.

NOTE: Do not over tighten

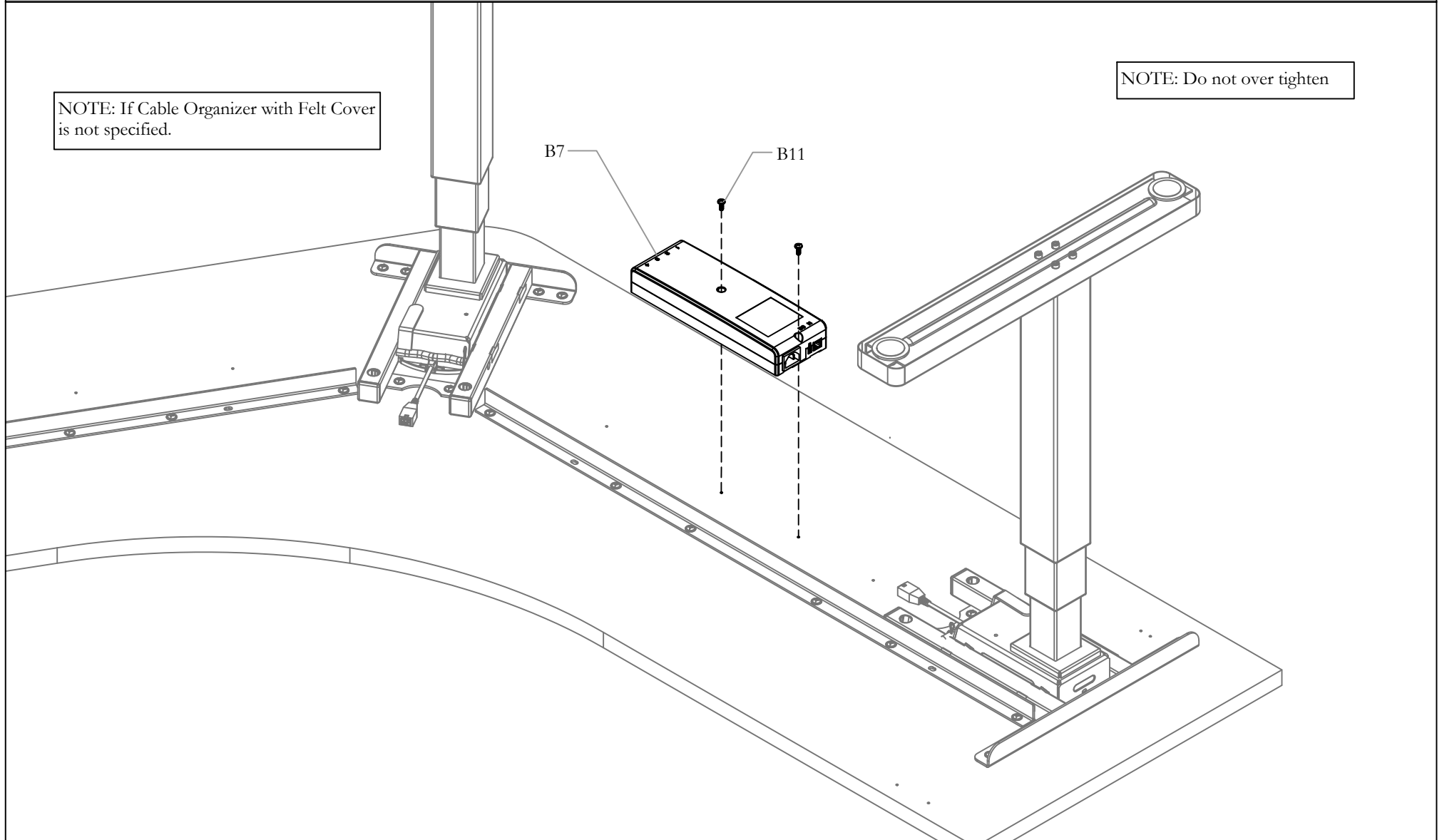

STEP 10b: If there is no Felt Cover Specified, secure Control Box (B7) directly to Worksurface as shown.

WARNING! Installers must not perform any electrical work while power is on. Care should be taken to test and confirm power is off prior to beginning any assembly and/or disassembly. Do not connect to power source until installation is complete. Connection to the building power source must be performed by a licensed electrician. Failure to follow these instructions poses significant risk of electrical shock, injury and damage. Only licensed electricians are authorized to make electrical connections in accordance with applicable codes and regulations.

ATTACH SWITCH AND CONNECT WIRES

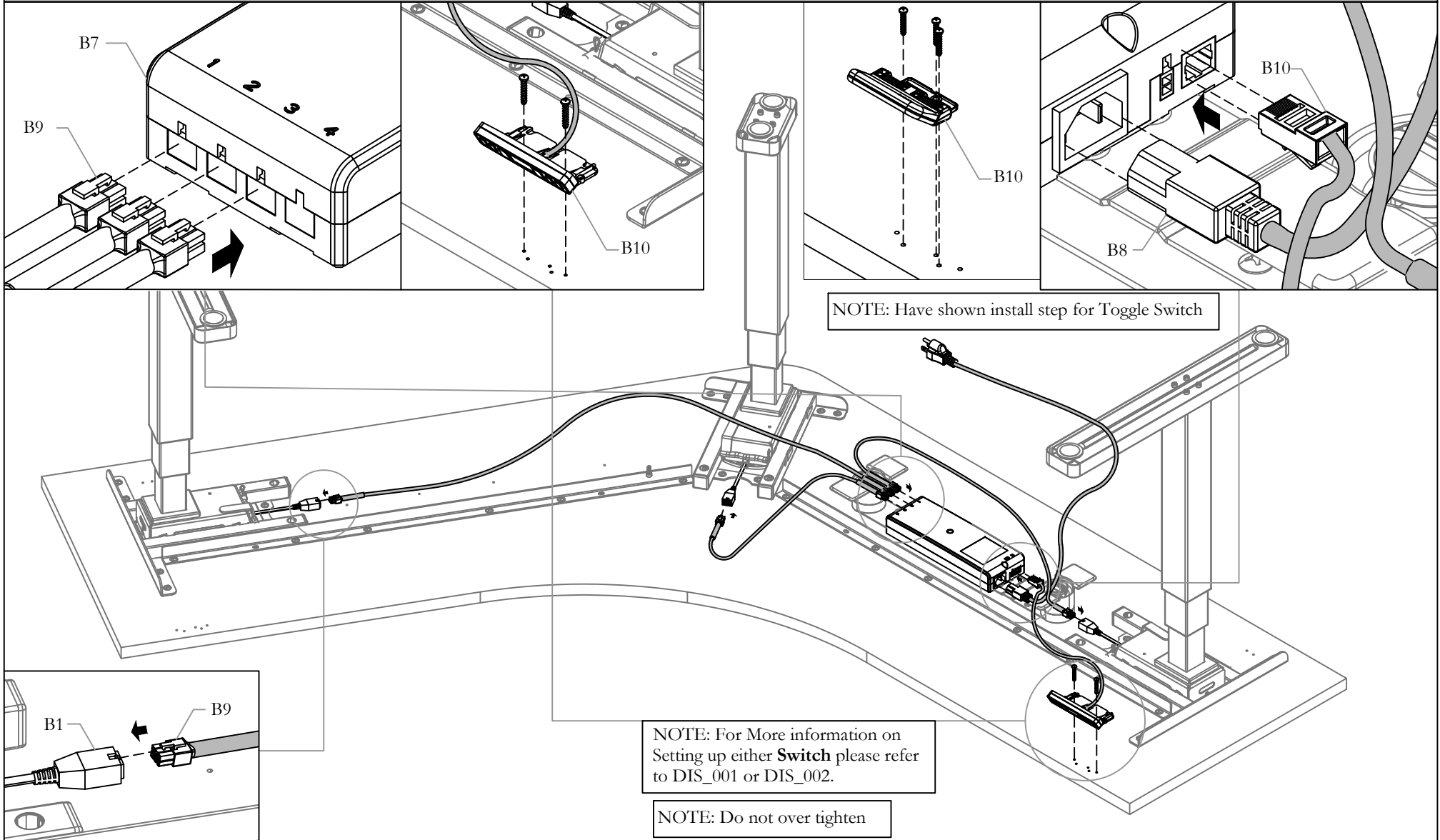

STEP 11: Attach Keypad (instructions are the same for both keypads) to Worksurface and connect to Control Box (B7) using attached cable. Attach each leg to the Control Box using Motor Cables (B9). Attach Power Cord (B8) to Control Box. Ensure that the switch cable has slack and does not affect the toggle movement.

WARNING! Installers must not perform any electrical work while power is on. Care should be taken to test and confirm power is off prior to beginning any assembly and/or disassembly. Do not connect to power source until installation is complete. Connection to the building power source must be performed by a licensed electrician. Failure to follow these instructions poses significant risk of electrical shock, injury and damage. Only licensed electricians are authorized to make electrical connections in accordance with applicable codes and regulations.

Section: HEIGHT ADJUSTABLE TABLES

Description: 120 HA TABLE - QUICK CONNECT

REASSEMBLE FELT COVER

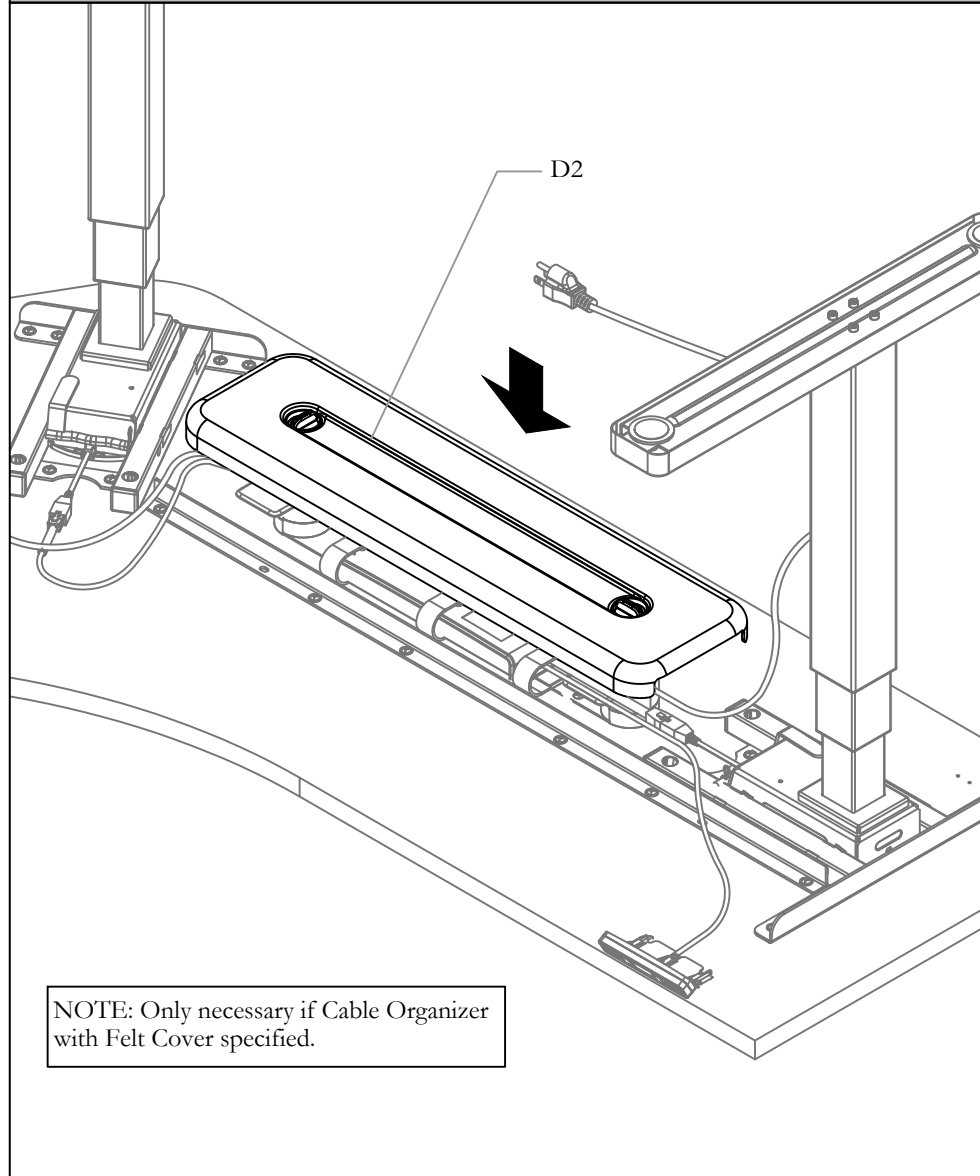

STEP 12: Attach Felt Cover (D2) to Wire Management Mounting Bracket.

SECURE FELT COVER

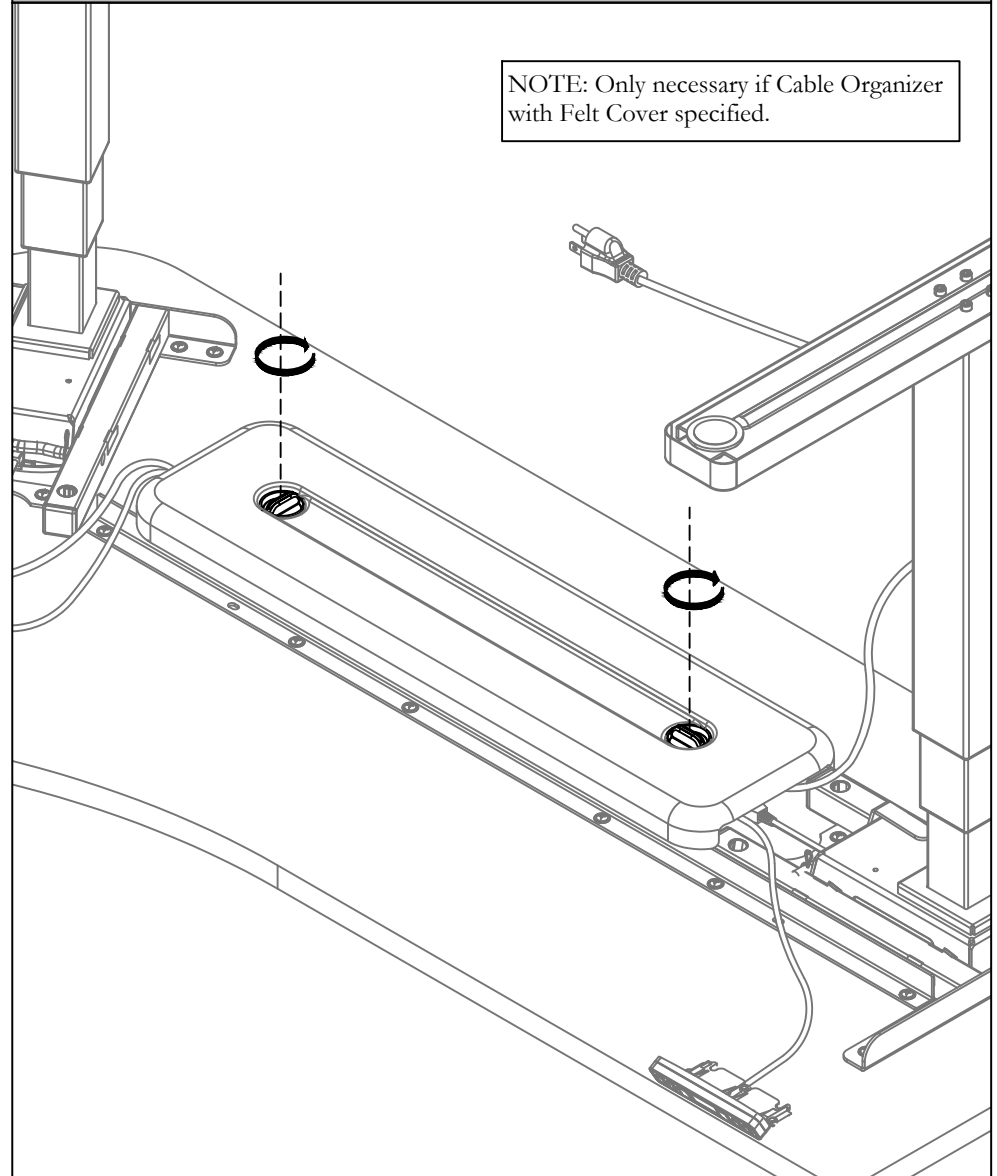

STEP 13: Rotate Screw Locks to secure cover.

WARNING! Installers must not perform any electrical work while power is on. Care should be taken to test and confirm power is off prior to beginning any assembly and/or disassembly. Do not connect to power source until installation is complete. Connection to the building power source must be performed by a licensed electrician. Failure to follow these instructions poses significant risk of electrical shock, injury and damage. Only licensed electricians are authorized to make electrical connections in accordance with applicable codes and regulations.

ATTACH WIRE MANAGEMENT TRAY (OPTIONAL)

NOTE: Only necessary if Cable Management Tray is specified

NOTE: The location of the Wire Management Tray is to be decided by the User according to their need.

NOTE: Do not over tighten.

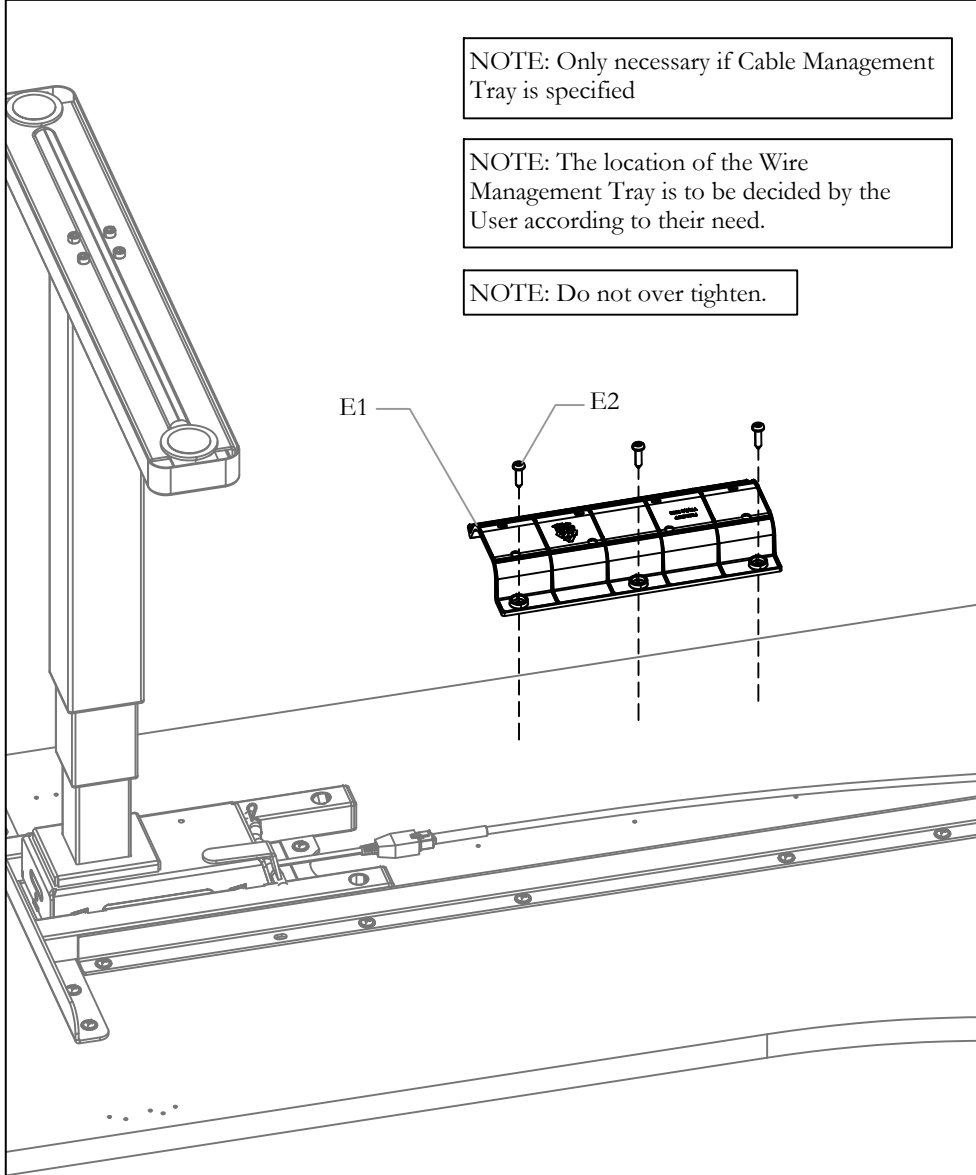

STEP (OPTIONAL): Attach the Management Tray (E1) to the Worksurface using provided screws (E2). Location to be decided by the User.

TIDY LOOSE WIRE (OPTIONAL)

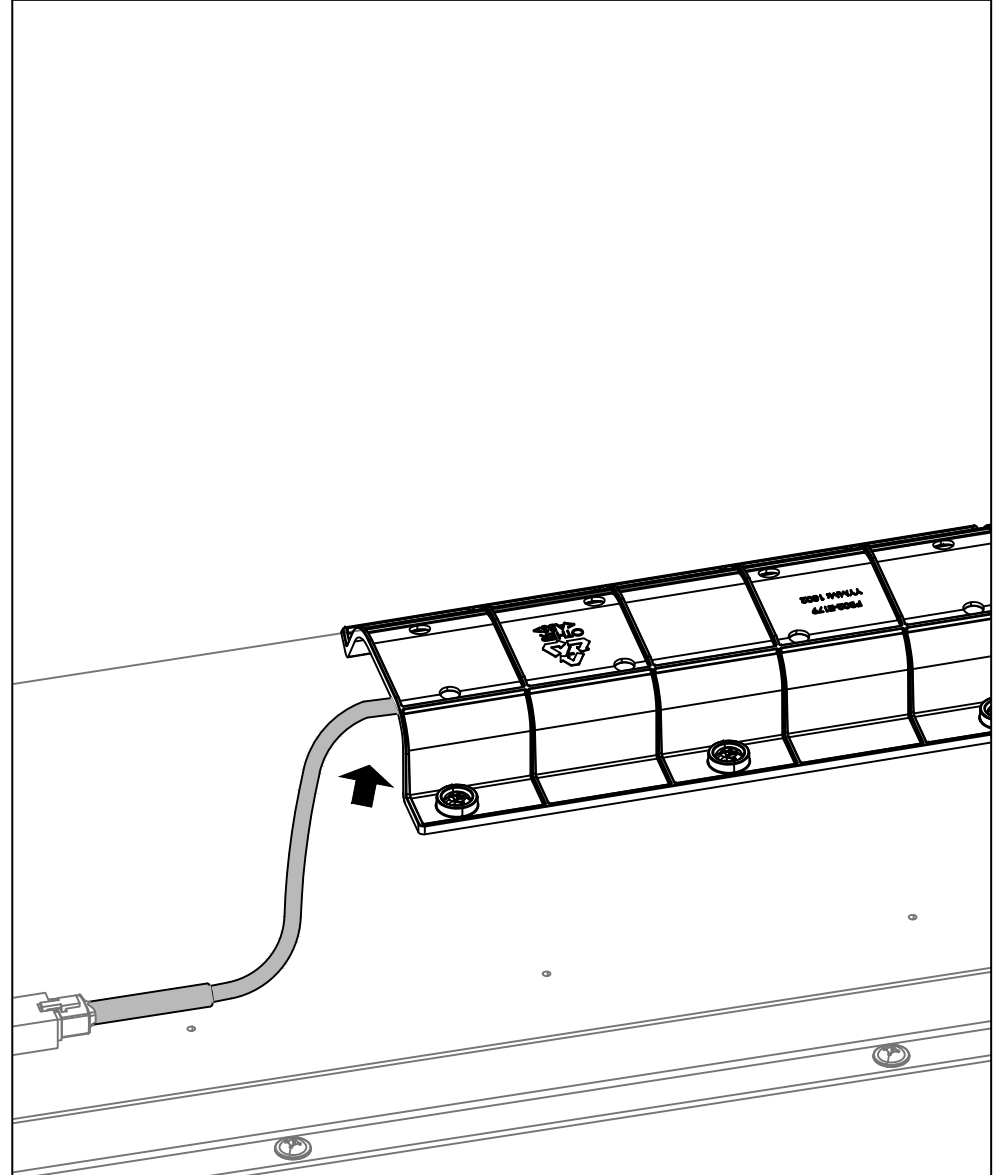

STEP (Optional): Place Loose wire inside Tray.

SECURE LOOSE WIRE

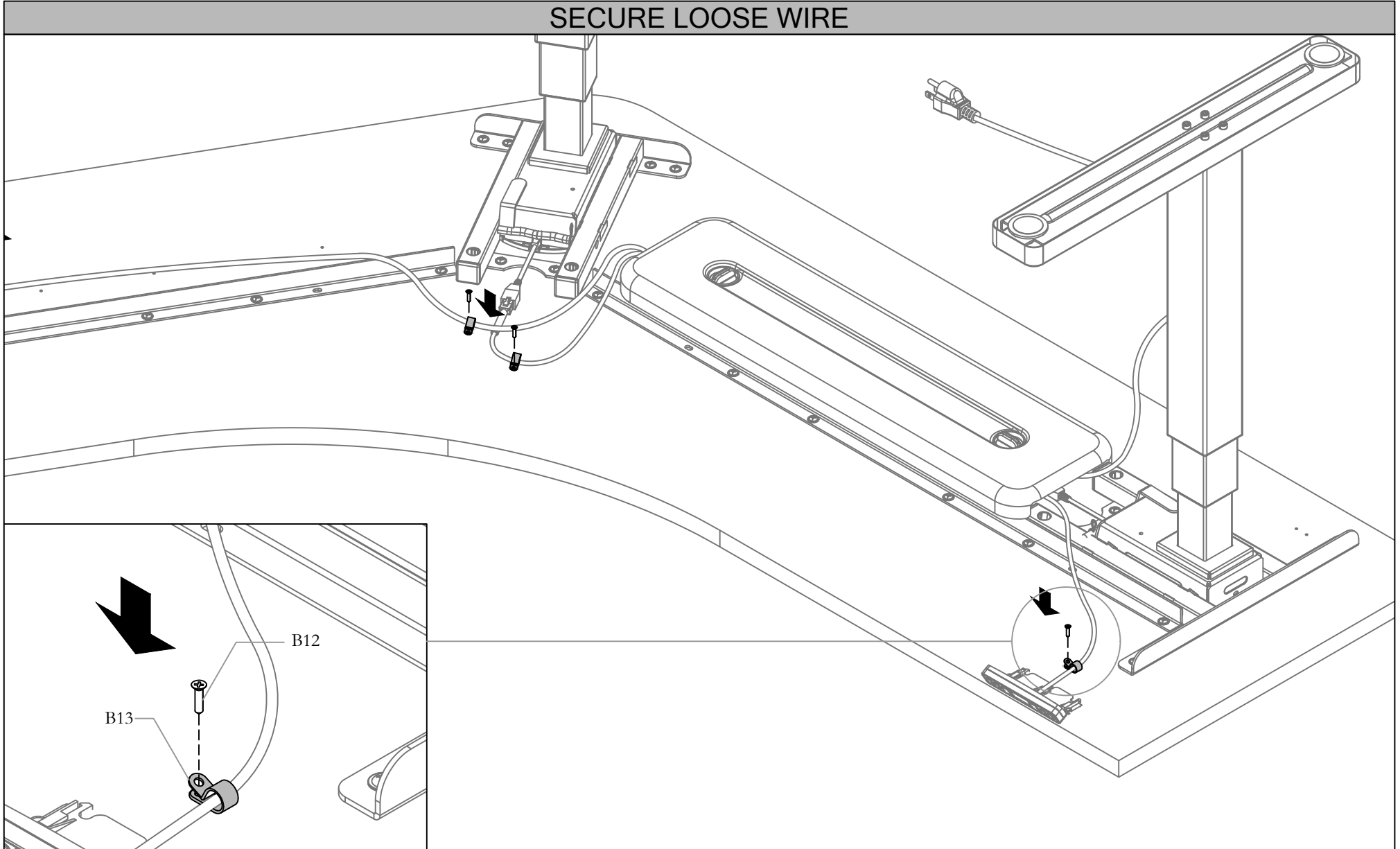

STEP 14: Secure loose wires to the Worksurface using Cable Clamps (B13).

WARNING! Installers must not perform any electrical work while power is on. Care should be taken to test and confirm power is off prior to beginning any assembly and/or disassembly. Do not connect to power source until installation is complete. Connection to the building power source must be performed by a licensed electrician. Failure to follow these instructions poses significant risk of electrical shock, injury and damage. Only licensed electricians are authorized to make electrical connections in accordance with applicable codes and regulations.

FLIP OVER TABLE

NOTE: Please make sure to have at least two people for this step.

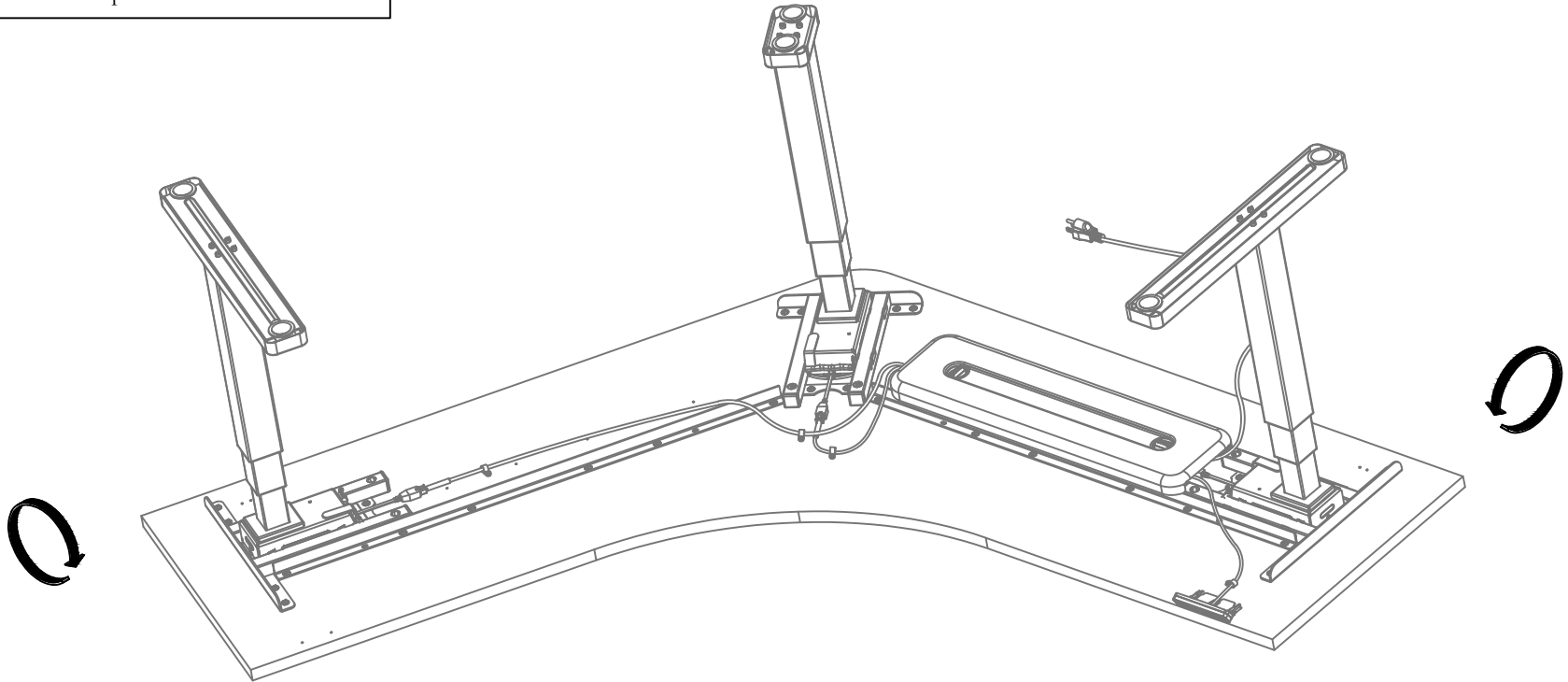

STEP 15: Flip over the Table.

ASSEMBLE VERTICAL WIRE CARRIER

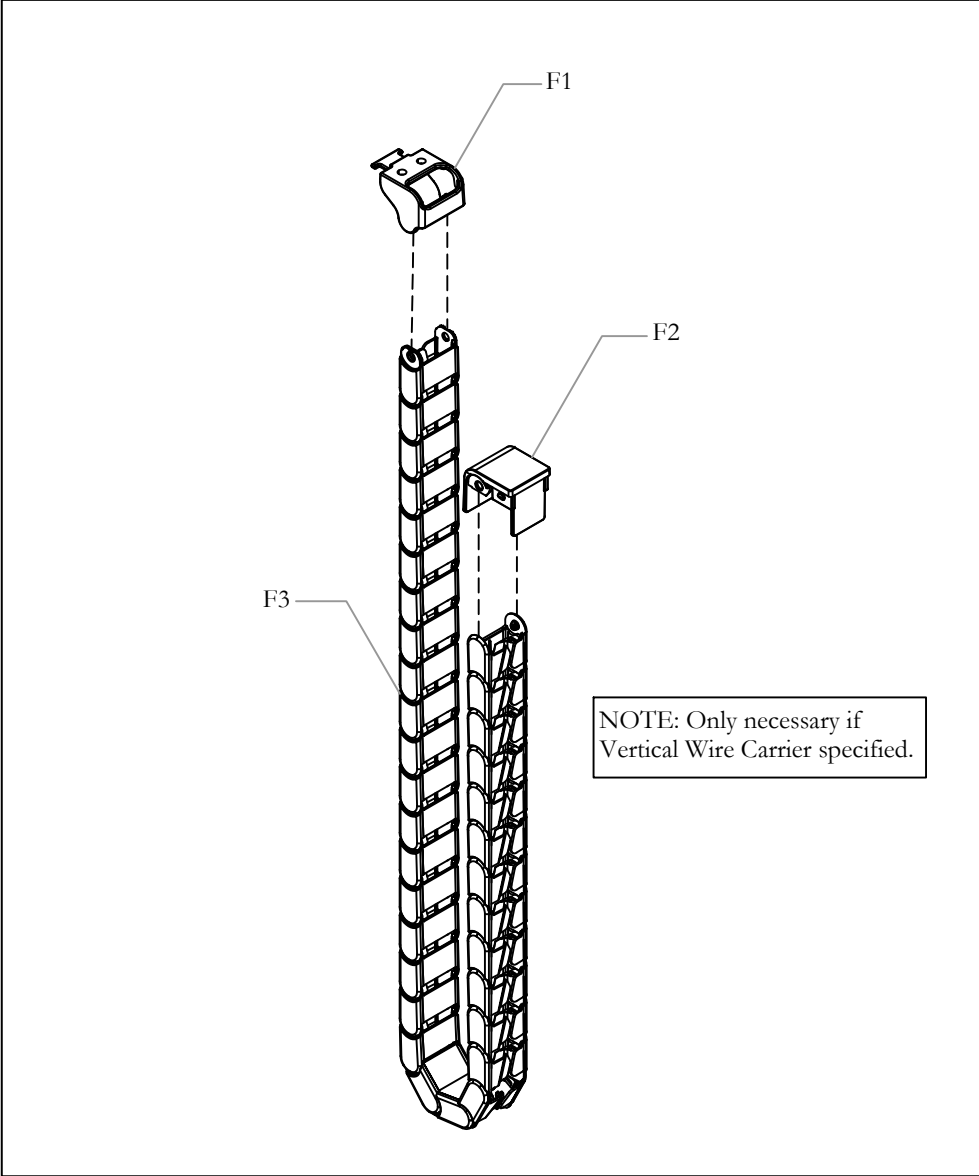

STEP 16: Attach Worksurface Connector and Leg Connector to the Vertical Wire Carrier Assembly as shown.

INSERT CABLE INTO WIRE CARRIER

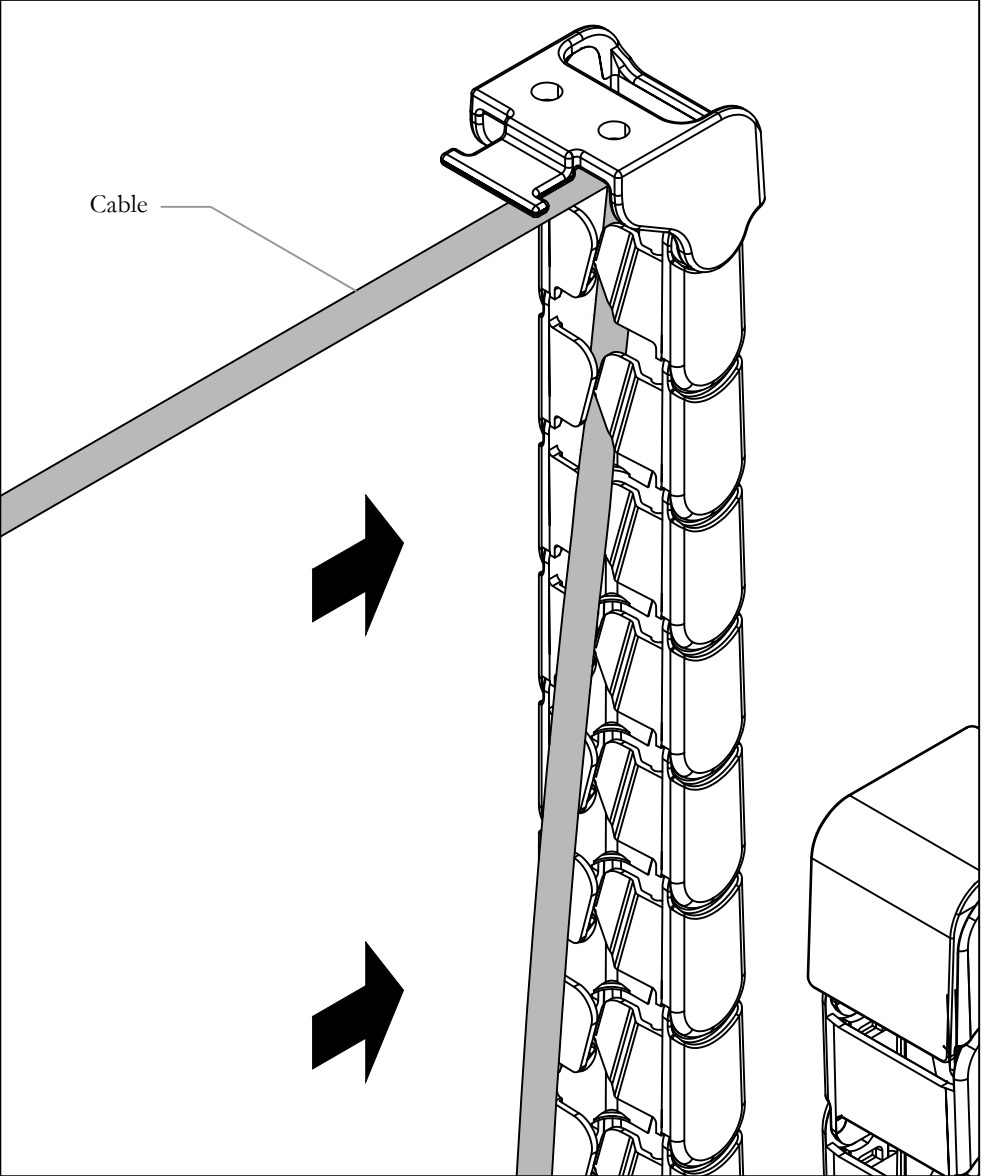

STEP 17: Insert Cable into the Wire Carrier as shown.

SECURE CABLE

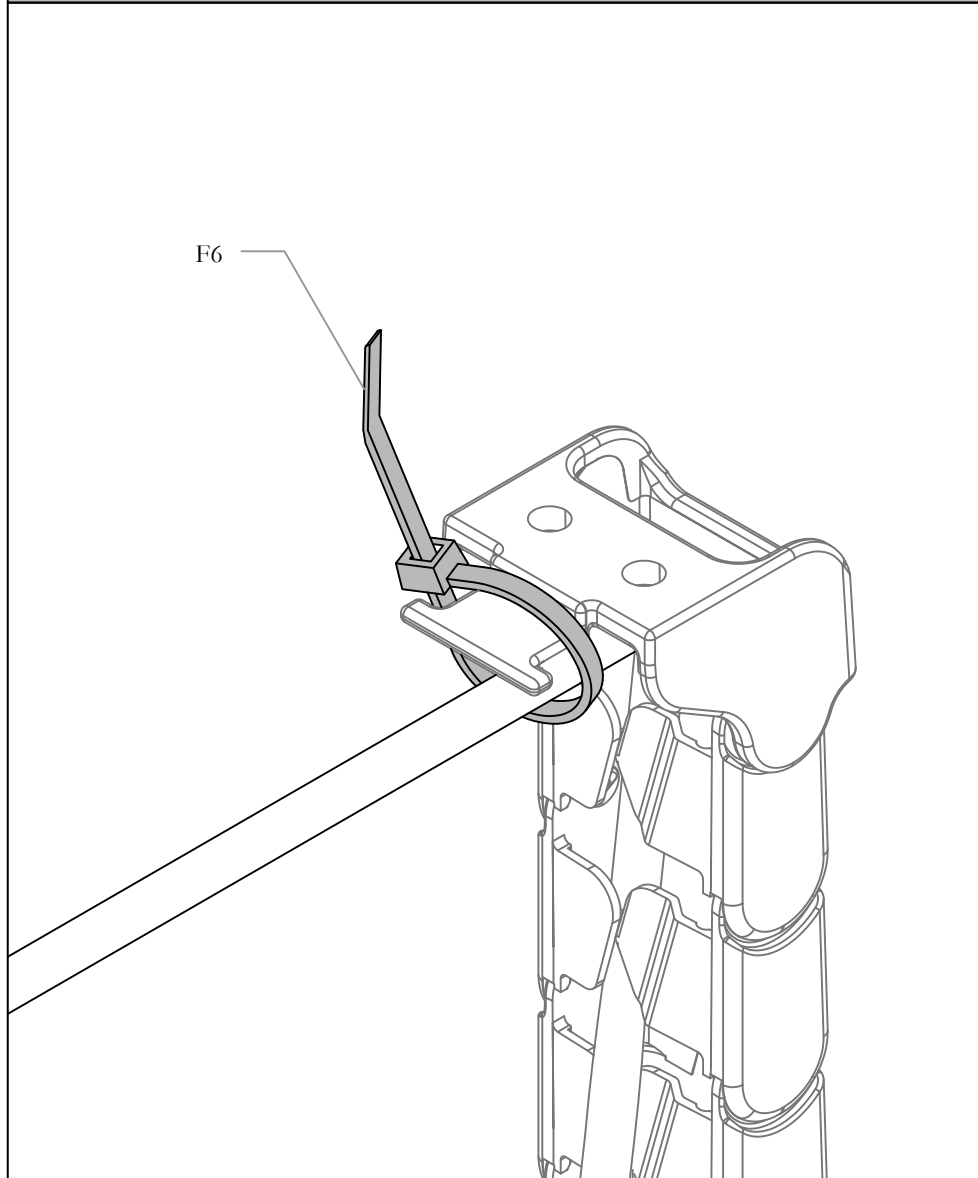

STEP 18: Secure cable to Wire Carrier using Cable Tie (F6).

ATTACH TO COVER ASSEMBLY

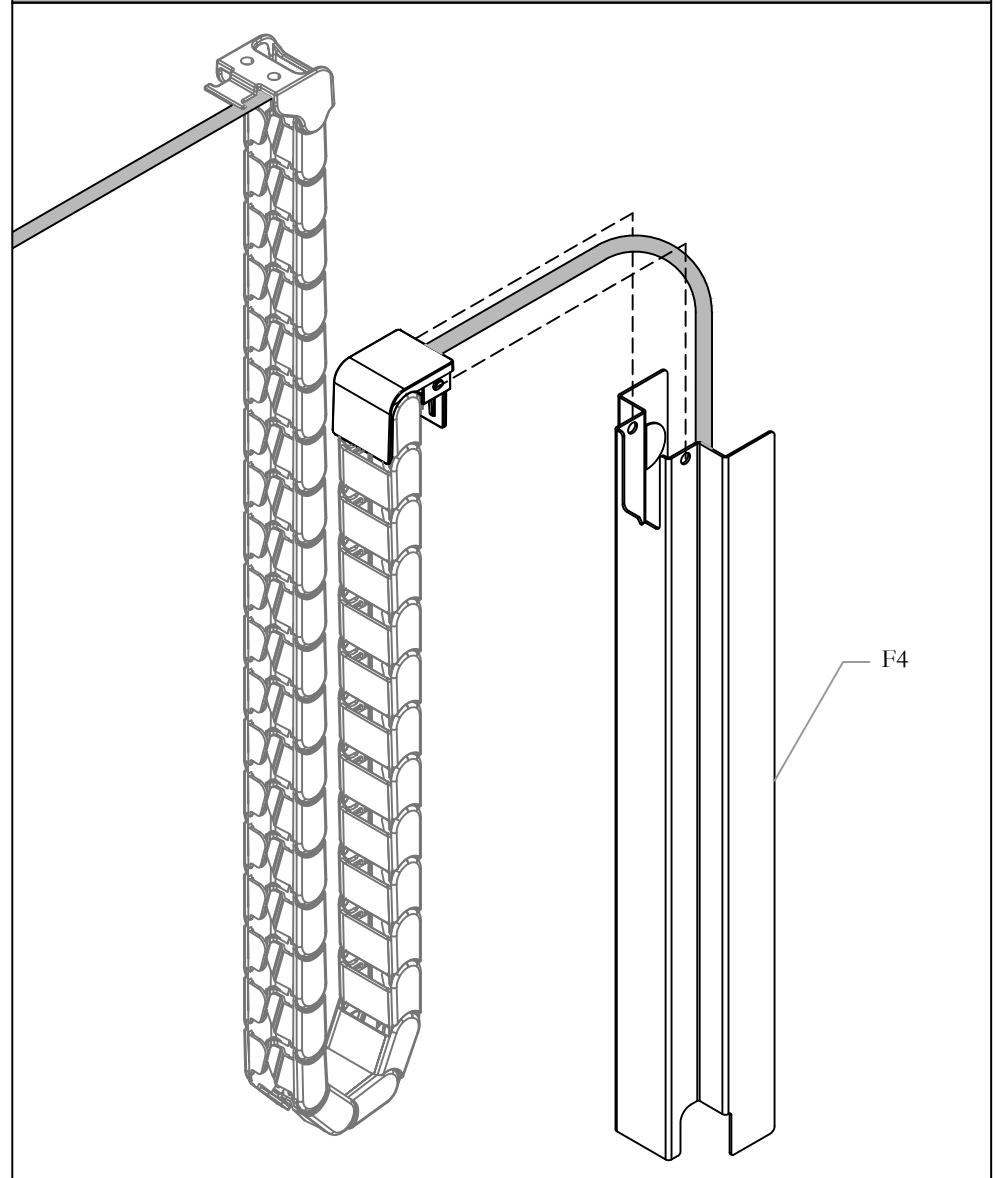

STEP 19: Feed Cable into the Vertical Cover & Pad Assembly (F4) before attaching the Wire Carrier as shown and snapping in place.

ATTACH TO LEG

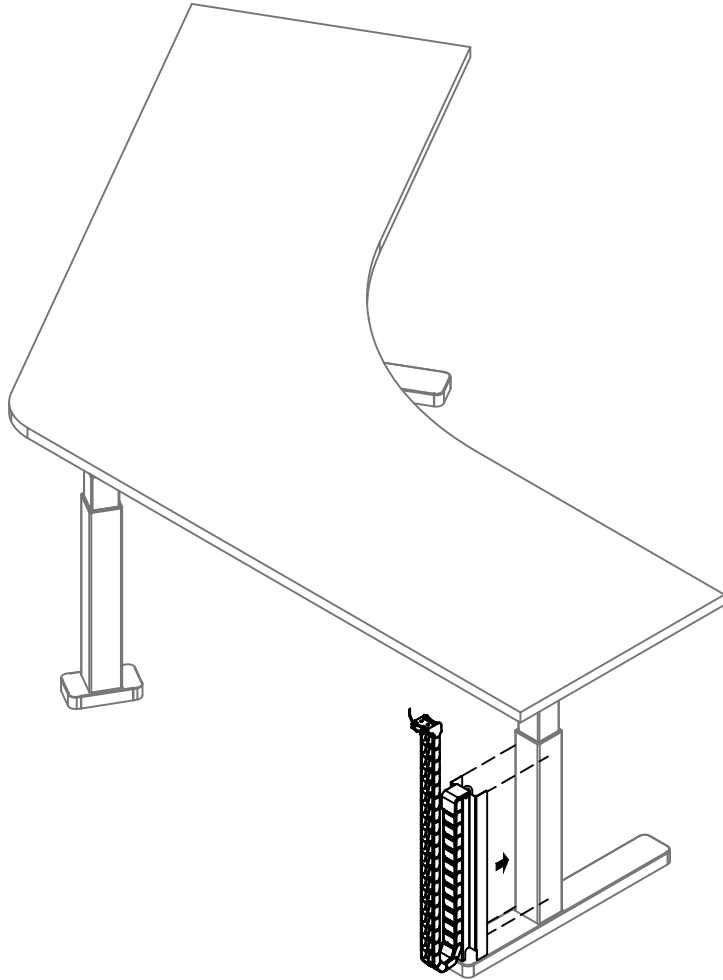

NOTE: Cable hidden for illustration purposes.

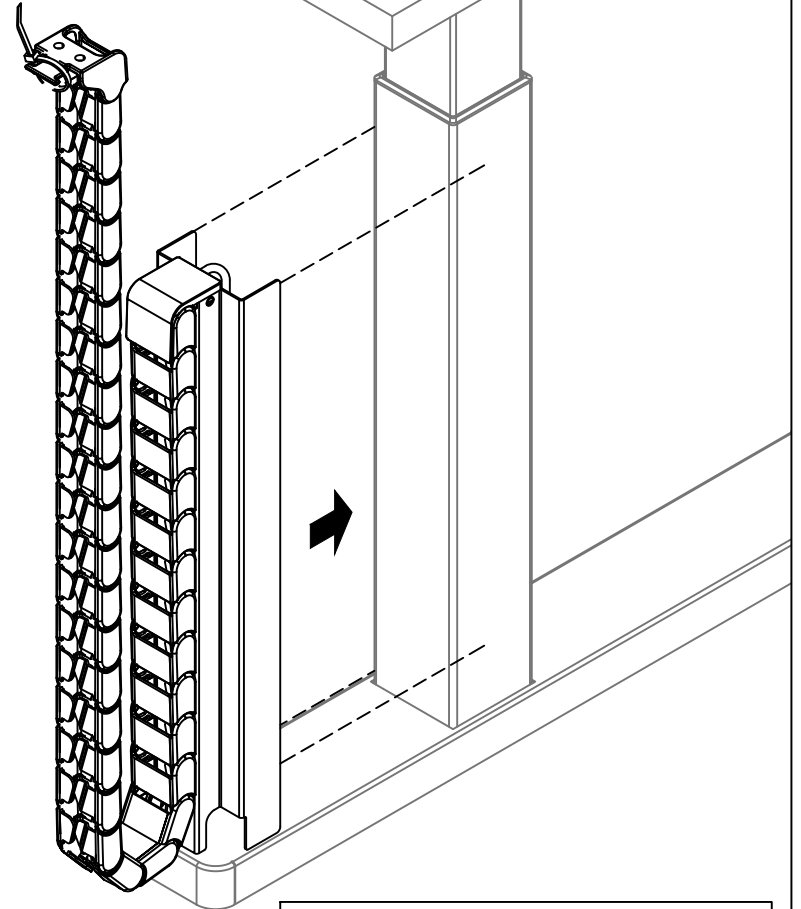

NOTE: Cable hidden for illustration purposes.

STEP 20: Attach Cover to Leg Post of Table as shown.

ATTACH TO WORKSURFACE

NOTE: Cable hidden for illustration purposes.

NOTE: Do not overtighten.

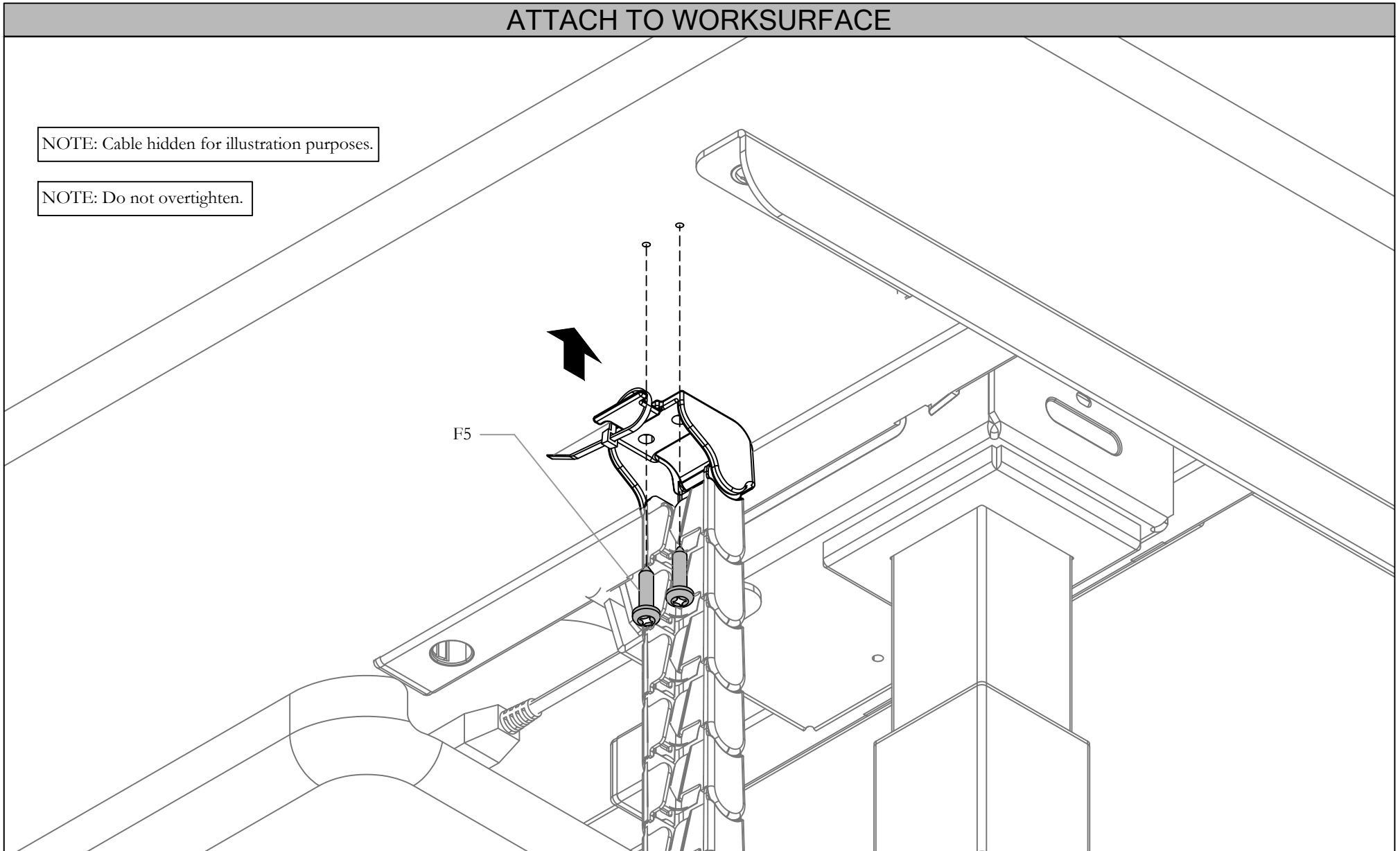

STEP 21: Secure Wire Carrier to underside of Worksurface using provided Screws (F5).

Parallelogram Height-Adjustable Worksurface (WBP),
 Parallelogram Freestanding Table Mechanism for District Power Spine (YSB)

WARNING!

Installers must not perform any electrical work while power is on. Care should be taken to test and confirm power is off prior to beginning any assembly and/or disassembly.

Do not connect to power source until installation is complete. Connection to the building power source must be performed by a licensed electrician.

Failure to follow these instructions poses significant risk of electrical shock, injury and damage.

Only licensed electricians are authorized to make electrical connections in accordance with applicable codes and regulations.





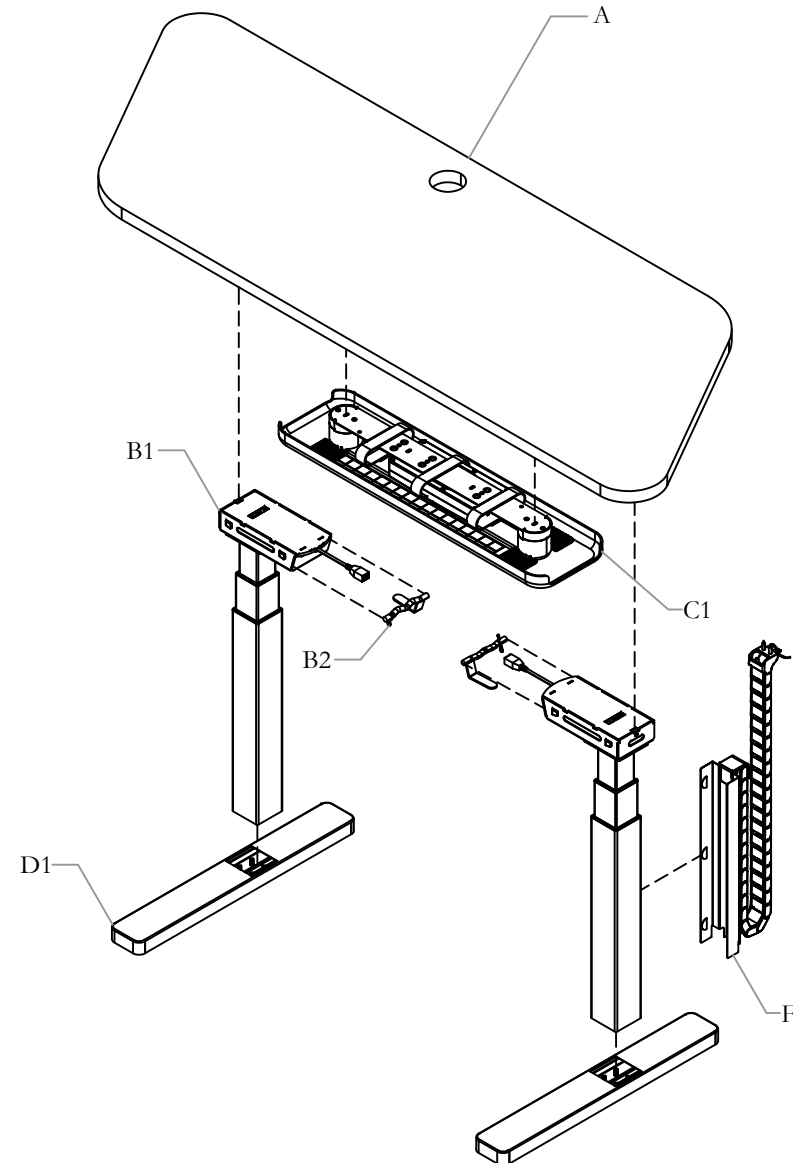





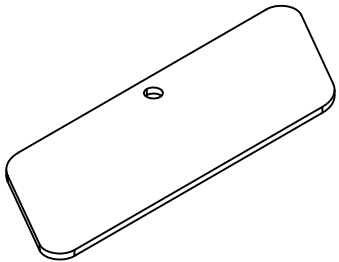
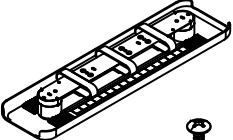

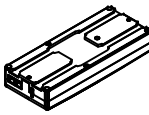
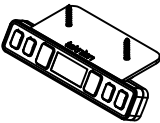
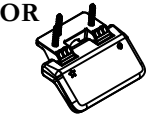

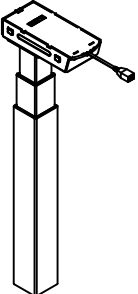
For Teknion Base Feed harnesses, any replacement of the fitting on the hardwired end of the liquidtight whip must be done by a licensed electrician using only fittings approved for the type of liquidtight conduit used on the base feed harness.

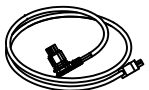
Failure to exactly follow these instructions renders Teknion's warranty and safety certifications null and void.

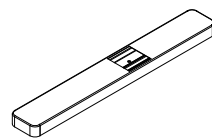

NOTE: Refer to DIS_1201b for Cable Management (YEYS).

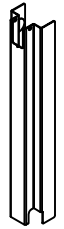
Part and Product Identification

 <p>A - PARALLELEGRAM HA Worksurface with Connection Kit for hiSpace Quick Connect with District Spine (WBP) x1</p>	<p>C-Cable Organizer with Felt Cover hiSpace2 (N09-9975) x1</p>	<p>E - Kaidi Hardware Kit for hiSpace2 (X05-0548) x1</p>
<p>B - hiSpace Quick Connect HA Parallelogram Freestanding Table Mechanism for District Power Spine (YSB) x1</p>	 <p>C1 - Large Cable Organizer with Felt Cover (N09-8069S) x 1</p>  <p>C1a - M5 x 20 Phillips Truss Head, Black (E07-0203) x 4</p>  <p>C2 - HiSpace Control Box with Anti-Collision, High Capacity (D06-4313\663) x1</p>  <p>C3 - Keypad, hiSpace Table (D06-4276) x1</p> <p>OR</p>  <p>Kaidi hiSpace Toggle Switch (N01-7336)x1</p>	 <p>E1 - #6 x 5/8" Quad WD Screw. (E04-0090) x 2</p>  <p>E2 - Cable Clamp 3/8, BLK (B02-0558) x 2</p>
 <p>B1 - Kaidi QI Bifma Range Leg, High Capacity (N01-8446) x2</p>  <p>B2 - Cam Handle hiSpace2 (N09-9814) x2</p>  <p>B3 - #8x1" Wood Screw (E04-0061) x 2</p>	<p>NOTE: Mounting Screws are included</p>  <p>C4 - Right Angle Connector Cable (D06-4277) x2</p>  <p>C5 - 3M US/CANADA power cord (D06-4136) x1</p> <p>D - YS Feet (Pair), hiSpace Table (N09-5784\X) x1</p>  <p>D1 - Foot Assembly, hiSpace Table (N09-5790\X) x2</p>  <p>D2 - M6x16, SHCS (E04-0096) x 8</p>	<p>F - Vertical Wire Carrier - hiSpace Workstation (N01-5114\16\34) x1</p>  <p>F1 - Vertical Wire Carrier Worksurface Connector (B02-0844) x1</p>  <p>F2 - Vertical Wire Carrier Leg Connector (B02-0844) x1</p>  <p>F3 - Vertical Wire Carrier Assembly (N01-6034-34) x1</p>  <p>F4 - Vertical Cover & Pad Assembly (N09-8474-16) x1</p>  <p>F5 - #12x7/8" WD Screw (E04-0087) x2</p>  <p>F6 - Cable Tie (B02-0545) x1</p>

ATTACH LEGS TO WORKSURFACE

NOTE: Worksurface upside down

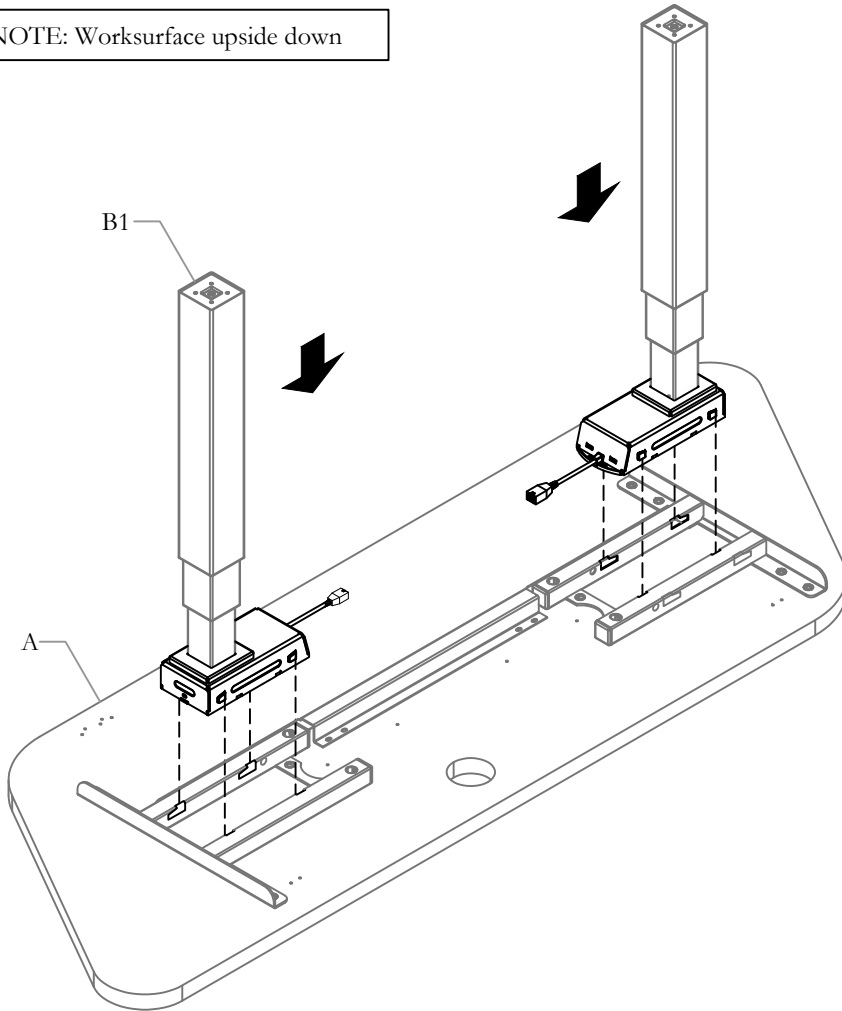

STEP 1: Attach Legs to Worksurface by lining up with holes as shown.

SECURE LEGS - 1

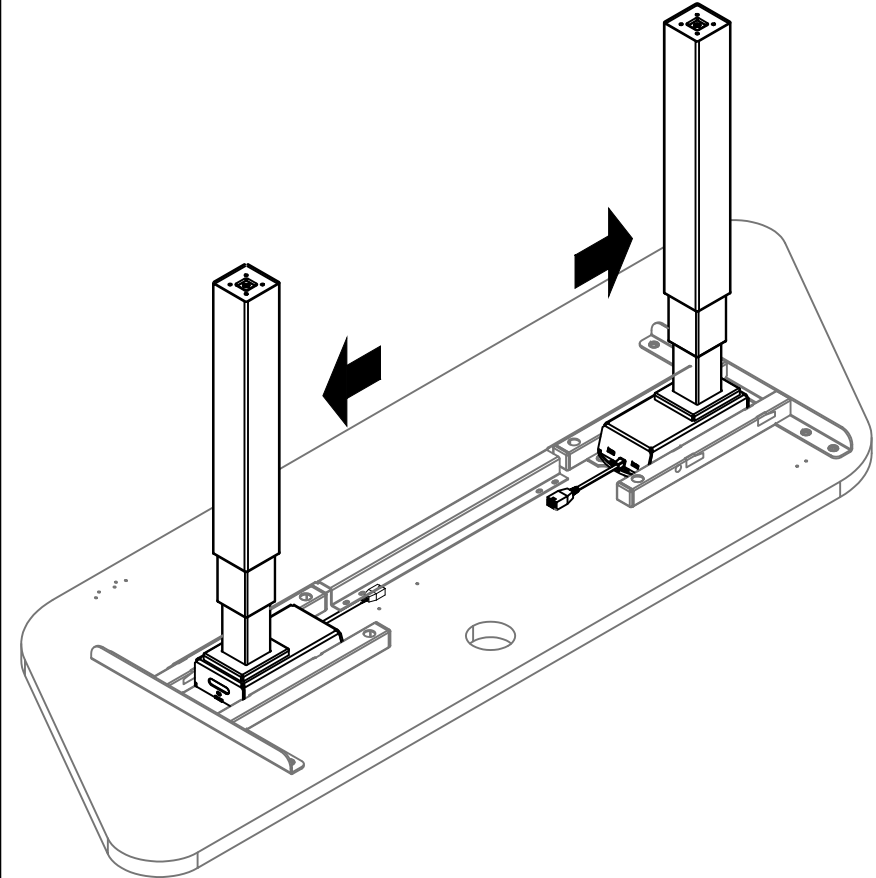

STEP 2: Push Legs towards the outer side of the Worksurface.

SECURE LEGS - 2

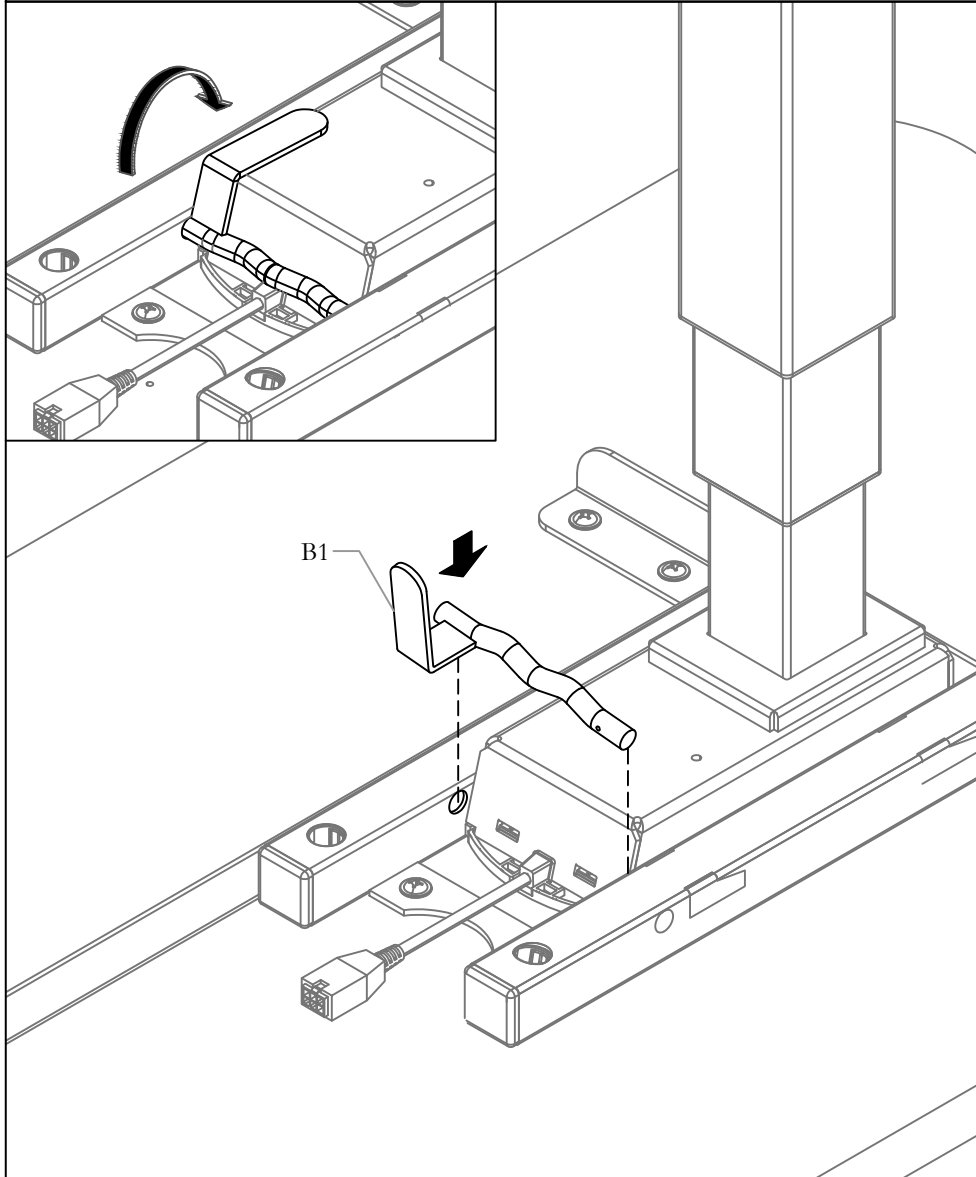

STEP 3: Install Cam Handles into Brackets, turning towards Leg to lock.

SECURE LEGS - 3

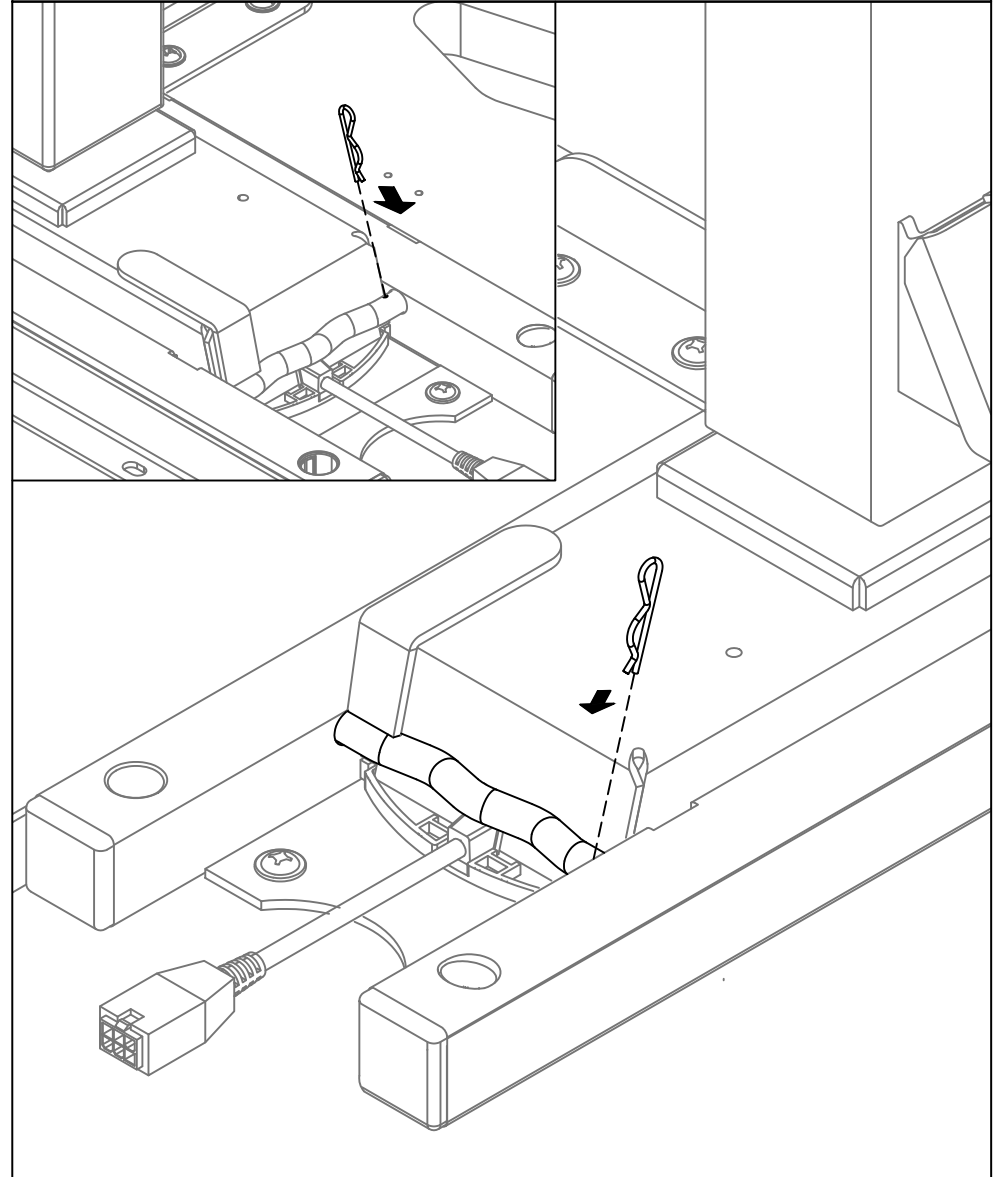

STEP 4: Insert Pin as shown.

ATTACH FEET

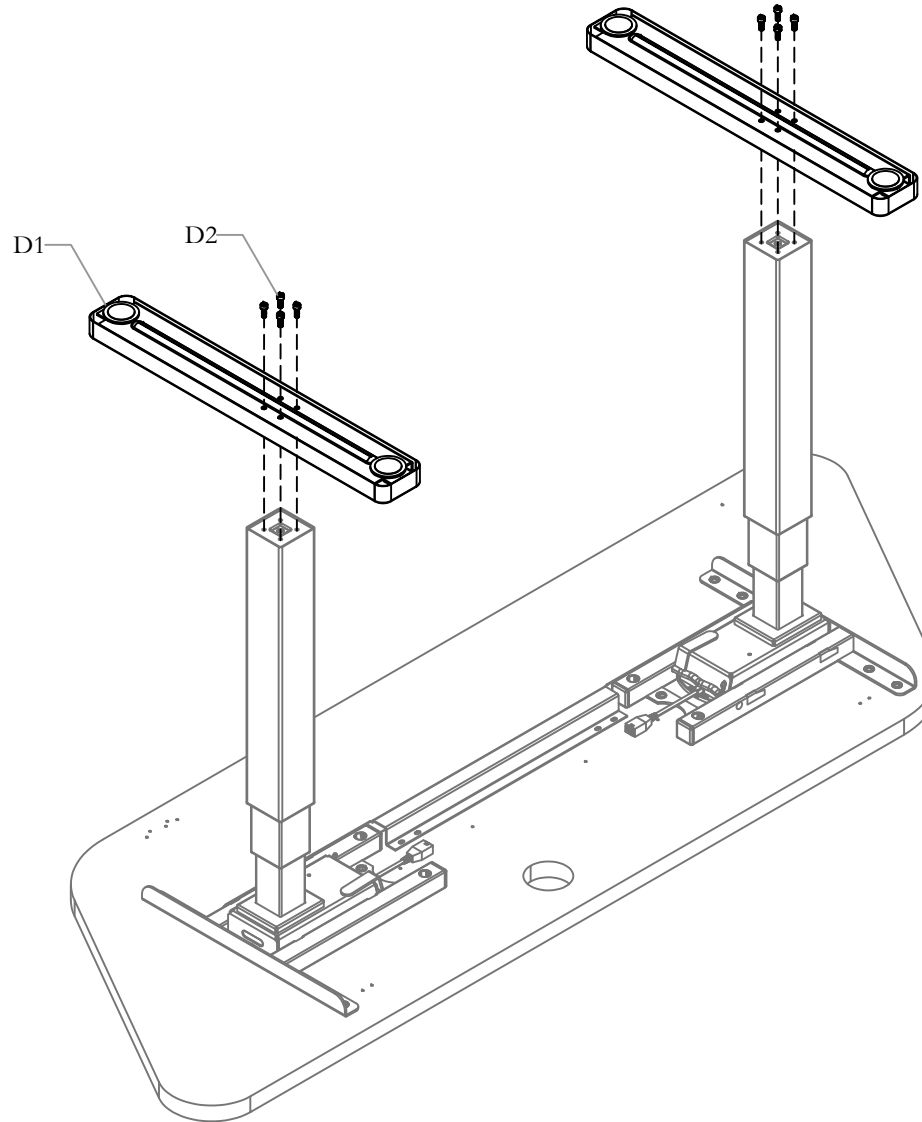

STEP 5: Attach Feet to Legs as shown using provided screws.

DISASSEMBLE FELT COVER

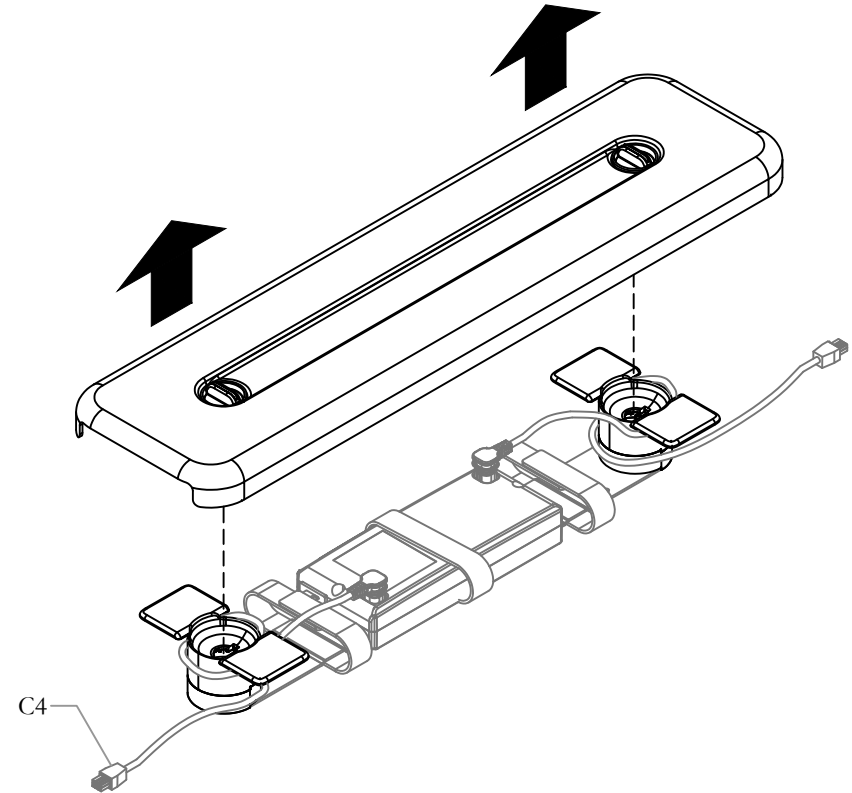
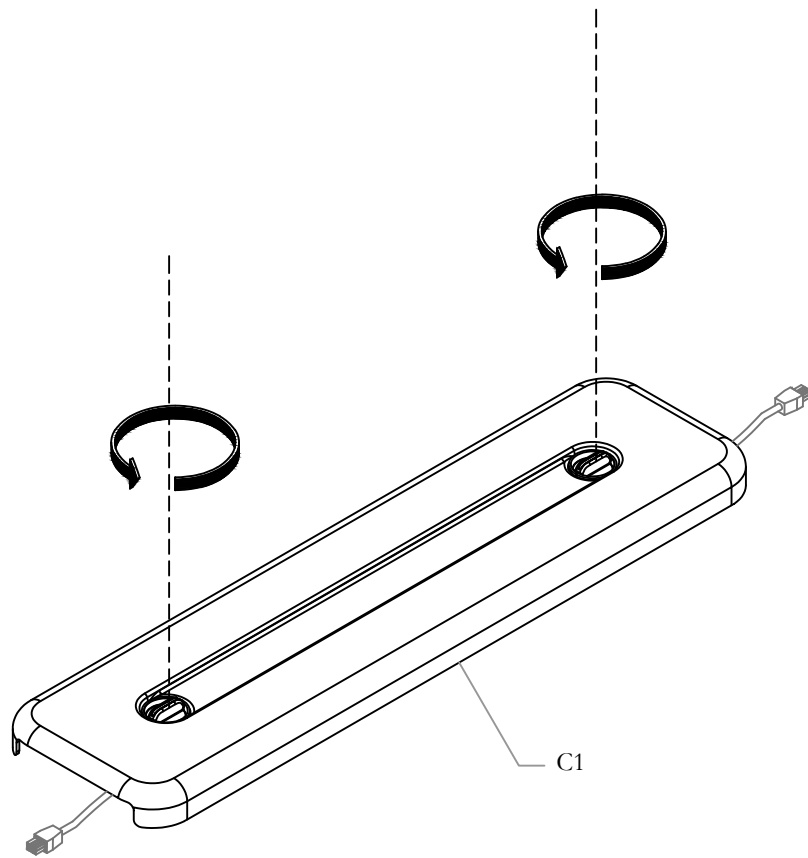

STEP 6: Disassemble Felt Cover as shown.

WARNING!

Installers must not perform any electrical work while power is on. Care should be taken to test and confirm power is off prior to beginning any assembly and/or disassembly. *Do not connect to power source until installation is complete. *Connection to the building power source must be performed by a licensed electrician. *Failure to follow these instructions poses significant risk of electrical shock, injury and damage. *Only licensed electricians are authorized to make electrical connections in accordance with applicable codes and regulations. *For Teknion Base Feed harnesses, any replacement of the fitting on the hardwired end of the liquidtight whip must be done by a licensed electrician using only fittings approved for the type of liquidtight conduit used on the base feed harness. *Failure to exactly follow these instructions renders Teknion's warranty and safety certifications null and void.

ATTACH CABLE ORGANIZER AND SWITCH. MAKE WIRE CONNECTIONS

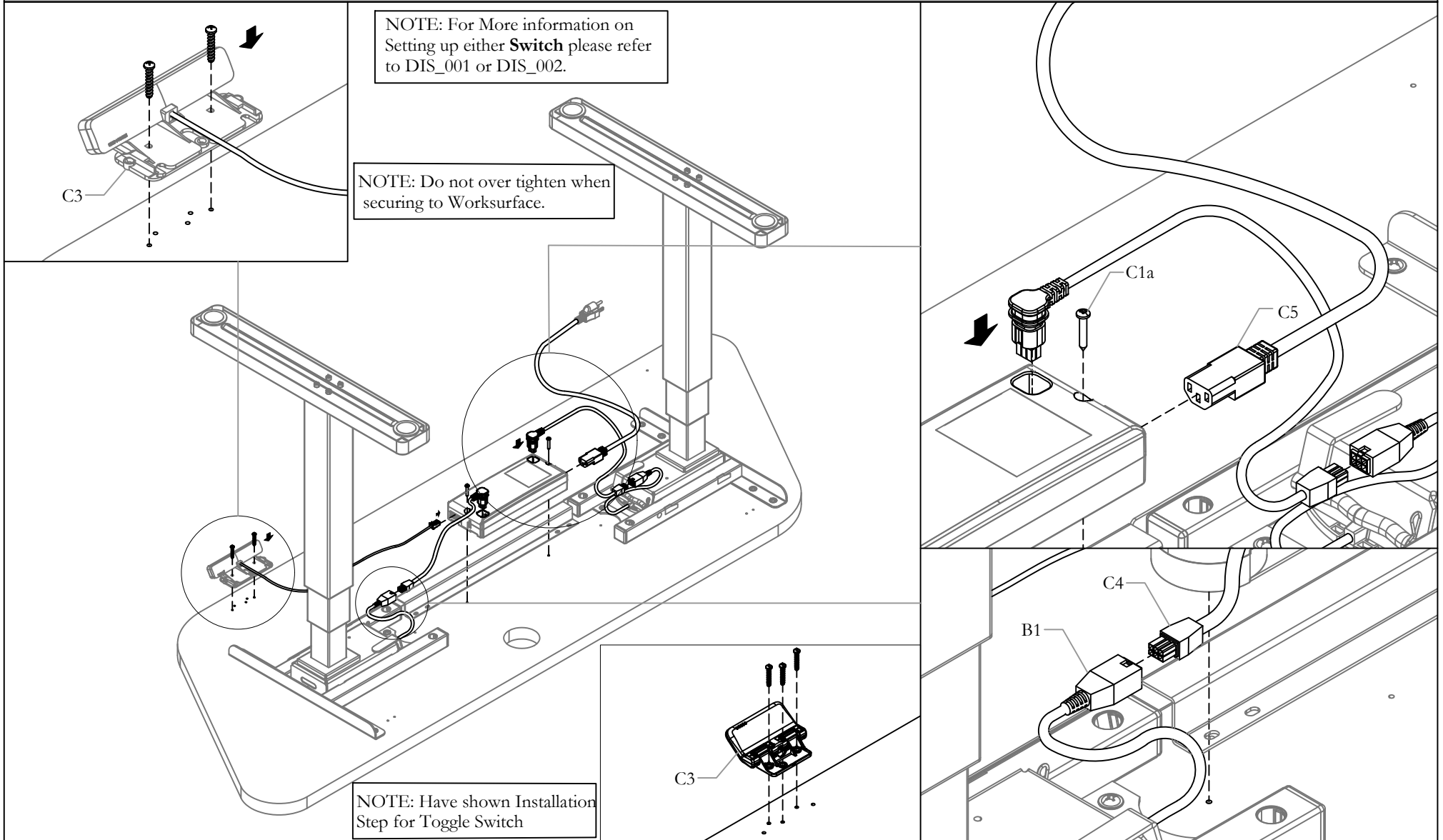

STEP 7: Attach the Cable Organizer, Power Cord and Keypad (instructions are the same for either Keypad) to the Worksurface. Make wire connections as shown. Ensure that the switch cable has slack and does not affect the toggle movement.

WARNING!

Installers must not perform any electrical work while power is on. Care should be taken to test and confirm power is off prior to beginning any assembly and/or disassembly. *Do not connect to power source until installation is complete. *Connection to the building power source must be performed by a licensed electrician. *Failure to follow these instructions poses significant risk of electrical shock, injury and damage. *Only licensed electricians are authorized to make electrical connections in accordance with applicable codes and regulations. *For Teknion Base Feed harnesses, any replacement of the fitting on the hardwired end of the liquidtight whip must be done by a licensed electrician using only fittings approved for the type of liquidtight conduit used on the base feed harness. *Failure to exactly follow these instructions renders Teknion's warranty and safety certifications null and void.

REASSEMBLE FELT COVER

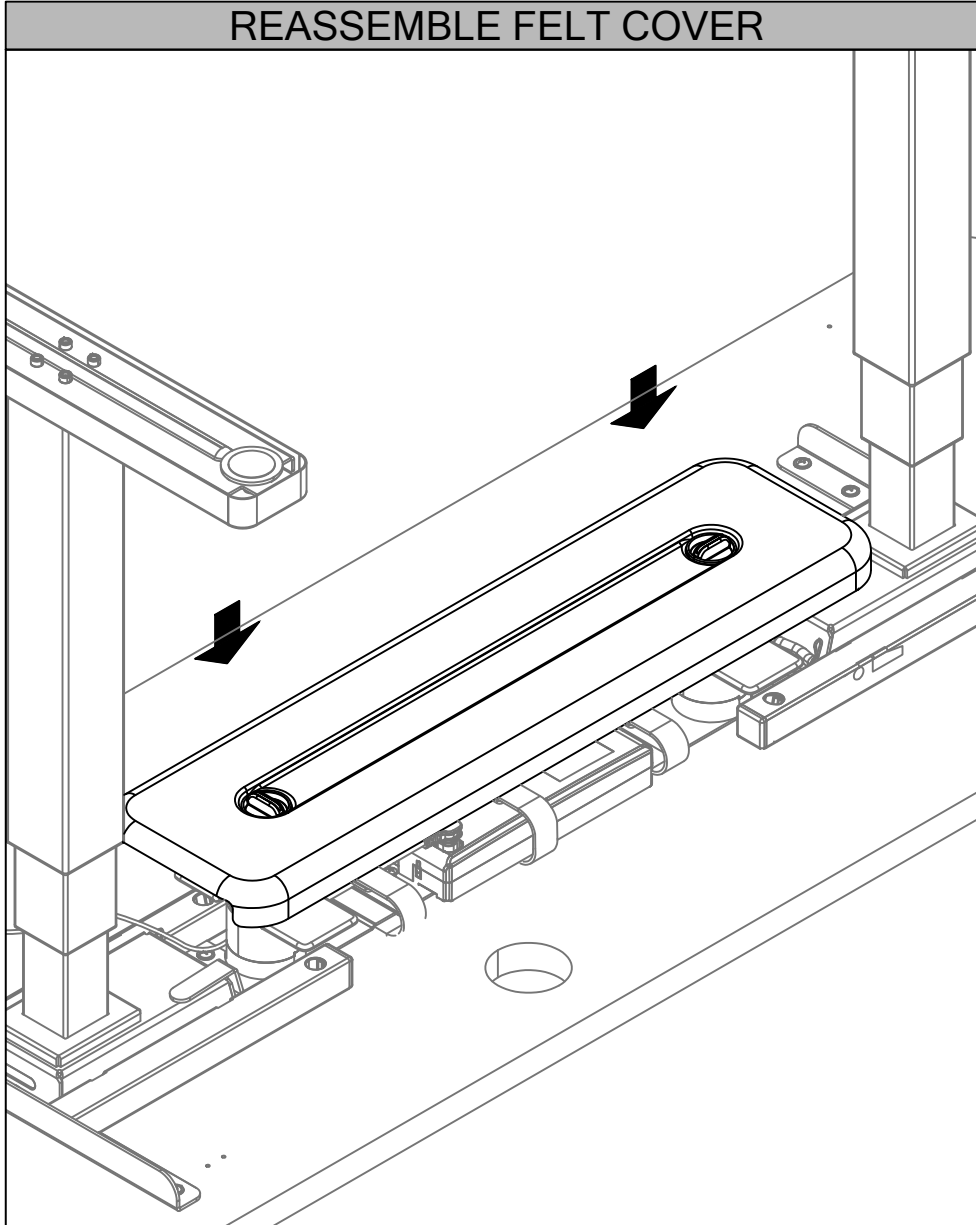

STEP 8: Reattach Felt Cover.

SECURE FELT COVER

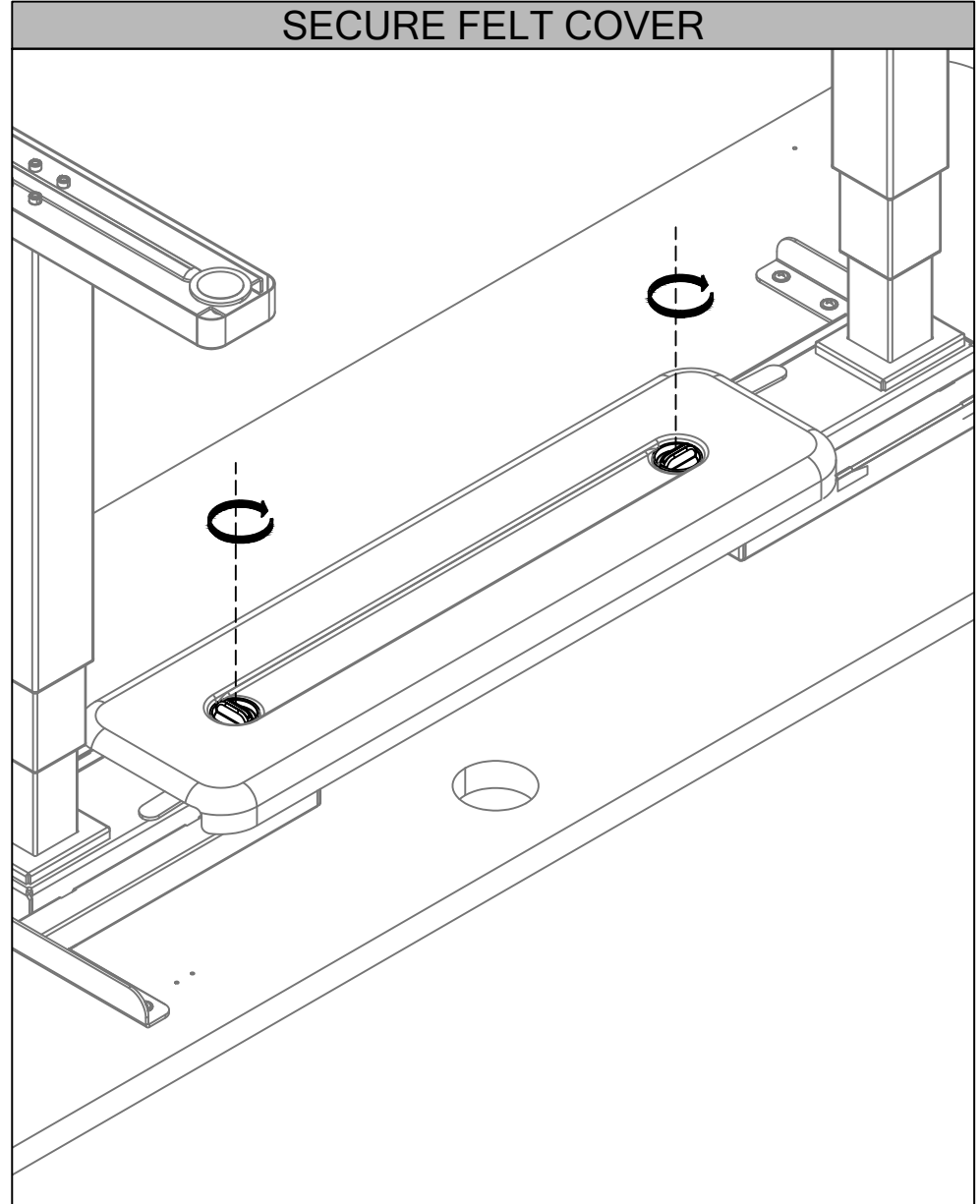

STEP 9: Rotate Screw Locks to secure.

WARNING!

Installers must not perform any electrical work while power is on. Care should be taken to test and confirm power is off prior to beginning any assembly and/or disassembly. *Do not connect to power source until installation is complete. *Connection to the building power source must be performed by a licensed electrician. *Failure to follow these instructions poses significant risk of electrical shock, injury and damage. *Only licensed electricians are authorized to make electrical connections in accordance with applicable codes and regulations. *For Teknion Base Feed harnesses, any replacement of the fitting on the hardwired end of the liquidtight whip must be done by a licensed electrician using only fittings approved for the type of liquidtight conduit used on the base feed harness. *Failure to exactly follow these instructions renders Teknion's warranty and safety certifications null and void.

SECURE LOOSE WIRE

NOTE: Do not over tighten when securing to Worksurface.

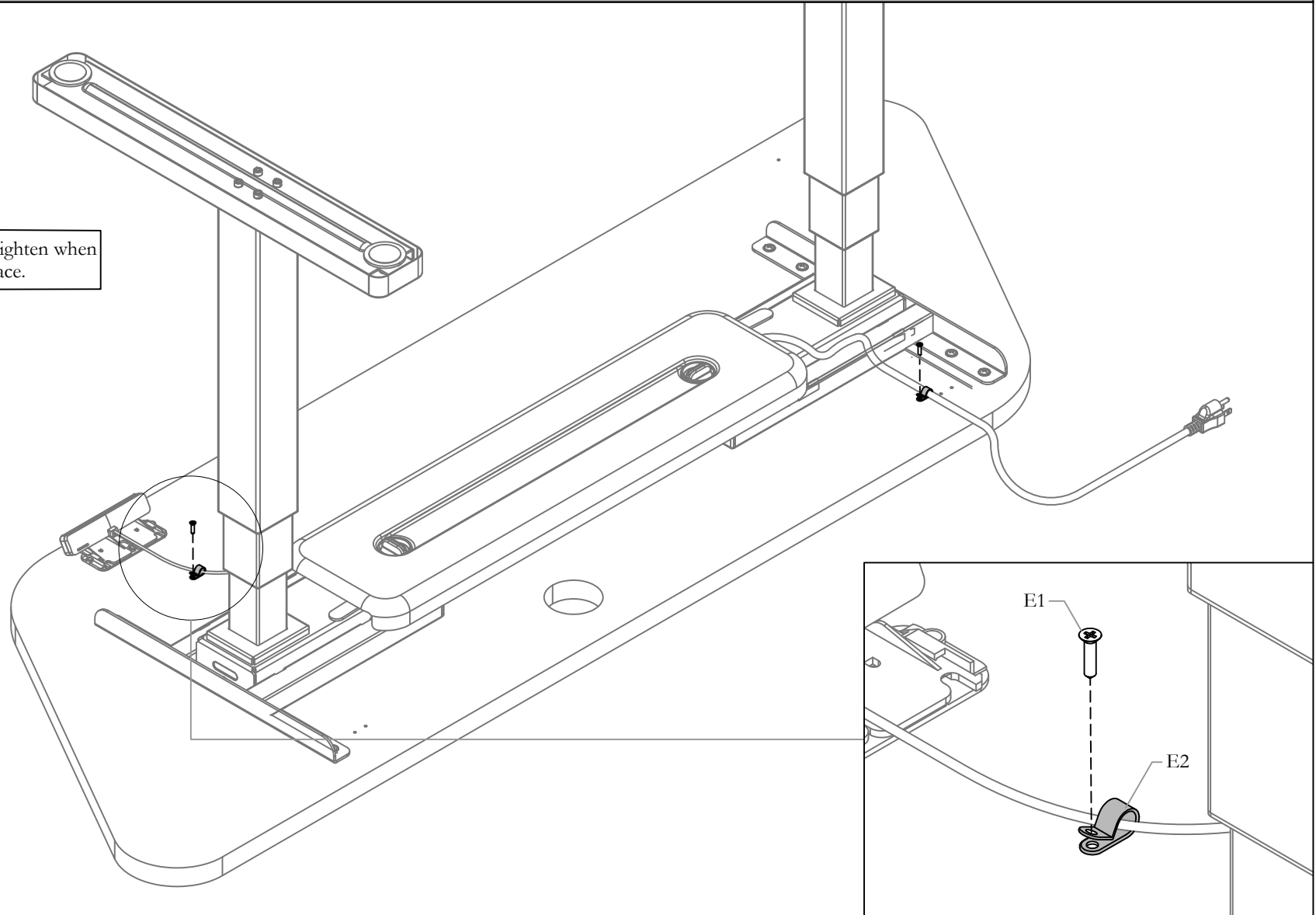

STEP 10: Secure loose wire to the Worksurface using Cable Clamps.

WARNING!

Installers must not perform any electrical work while power is on. Care should be taken to test and confirm power is off prior to beginning any assembly and/or disassembly. *Do not connect to power source until installation is complete. *Connection to the building power source must be performed by a licensed electrician. *Failure to follow these instructions poses significant risk of electrical shock, injury and damage. *Only licensed electricians are authorized to make electrical connections in accordance with applicable codes and regulations. *For Teknion Base Feed harnesses, any replacement of the fitting on the hardwired end of the liquidtight whip must be done by a licensed electrician using only fittings approved for the type of liquidtight conduit used on the base feed harness. *Failure to exactly follow these instructions renders Teknion's warranty and safety certifications null and void.

FLIP OVER TABLE

NOTE: Please make sure to have at least two people for this step.

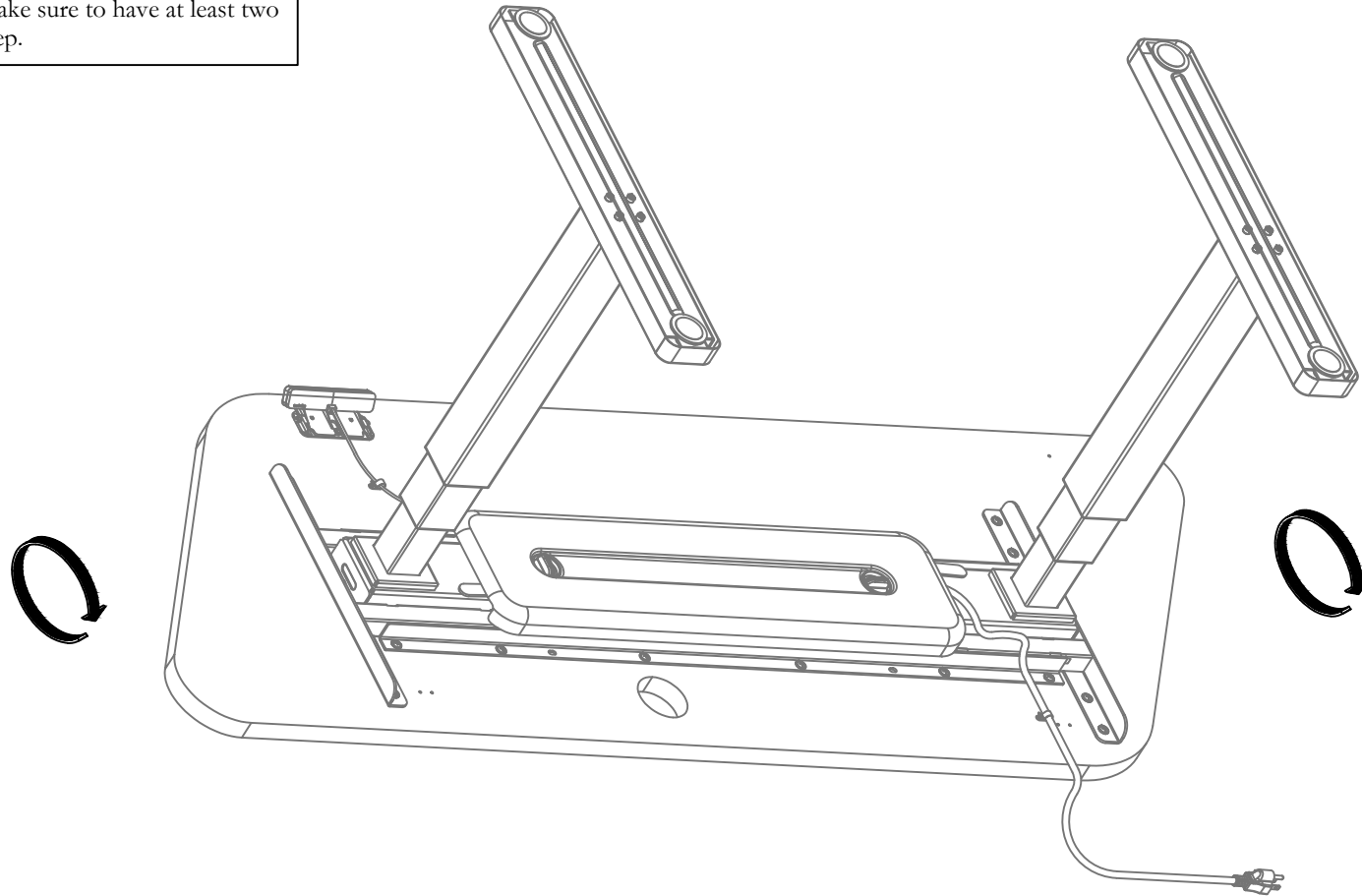

STEP 11: Flip over table

ASSEMBLE VERTICAL WIRE CARRIER

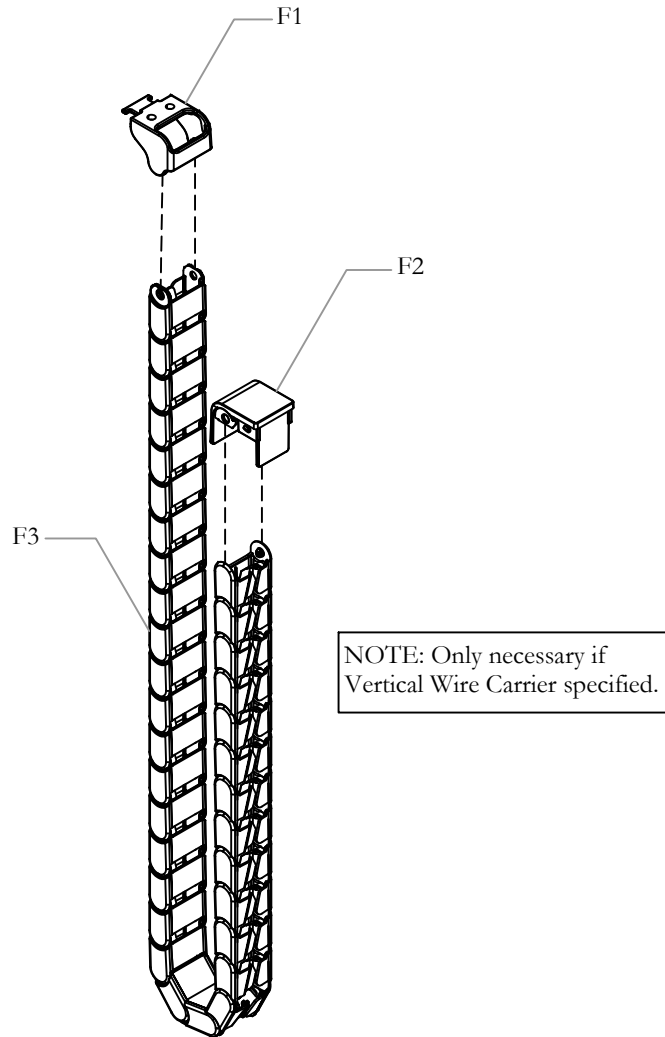

STEP 12: Attach Worksurface Connector and Leg Connector to the Vertical Wire Carrier Assembly.

WARNING!

Installers must not perform any electrical work while power is on. Care should be taken to test and confirm power is off prior to beginning any assembly and/or disassembly. *Do not connect to power source until installation is complete. *Connection to the building power source must be performed by a licensed electrician. *Failure to follow these instructions poses significant risk of electrical shock, injury and damage. *Only licensed electricians are authorized to make electrical connections in accordance with applicable codes and regulations. *For Tekunion Base Feed harnesses, any replacement of the fitting on the hardwired end of the liquidtight whip must be done by a licensed electrician using only fittings approved for the type of liquidtight conduit used on the base feed harness. *Failure to exactly follow these instructions renders Tekunion's warranty and safety certifications null and void.

INSERT CABLE INTO WIRE CARRIER

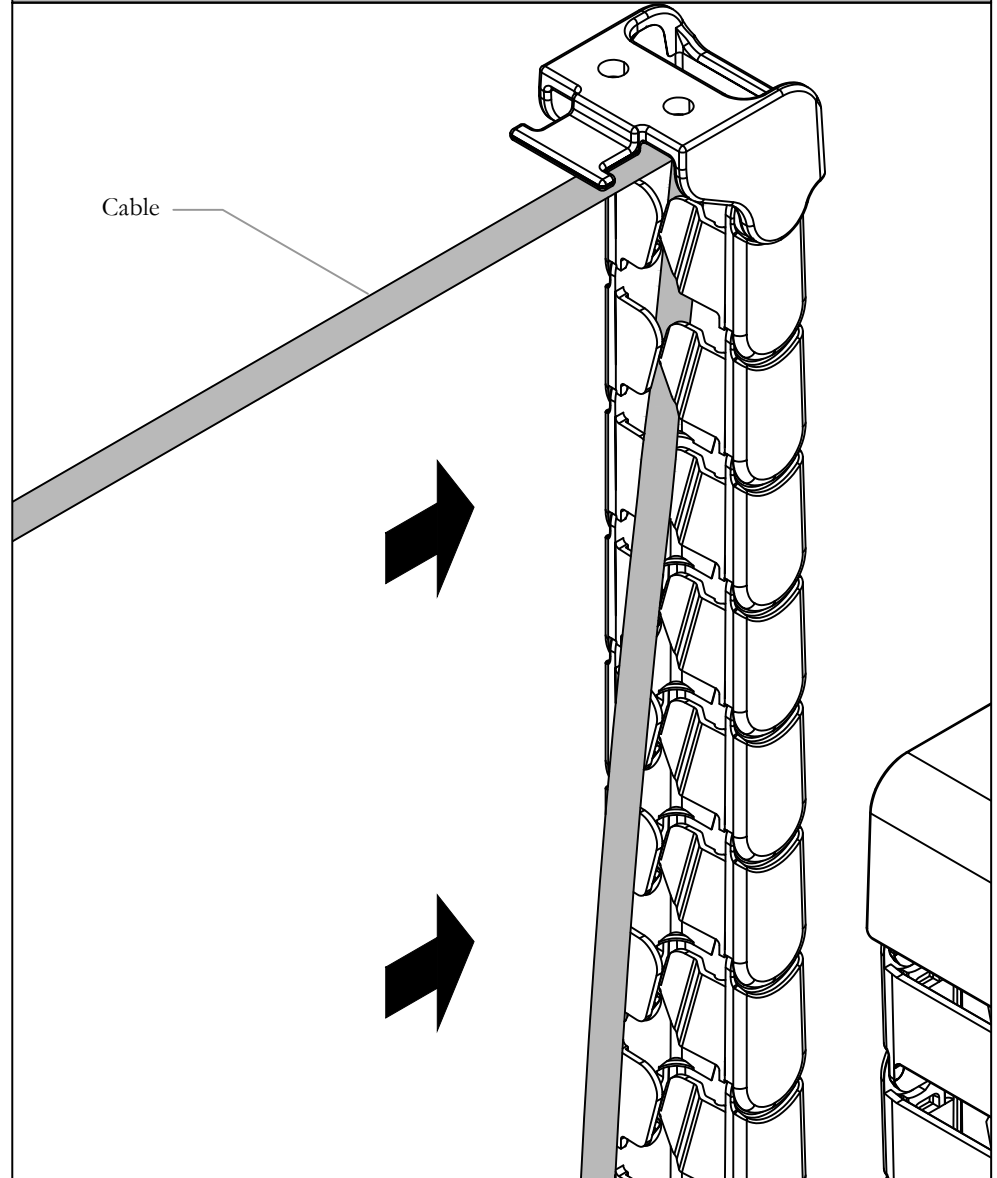

STEP 13: Insert Cable into Wire Carrier.

SECURE CABLE

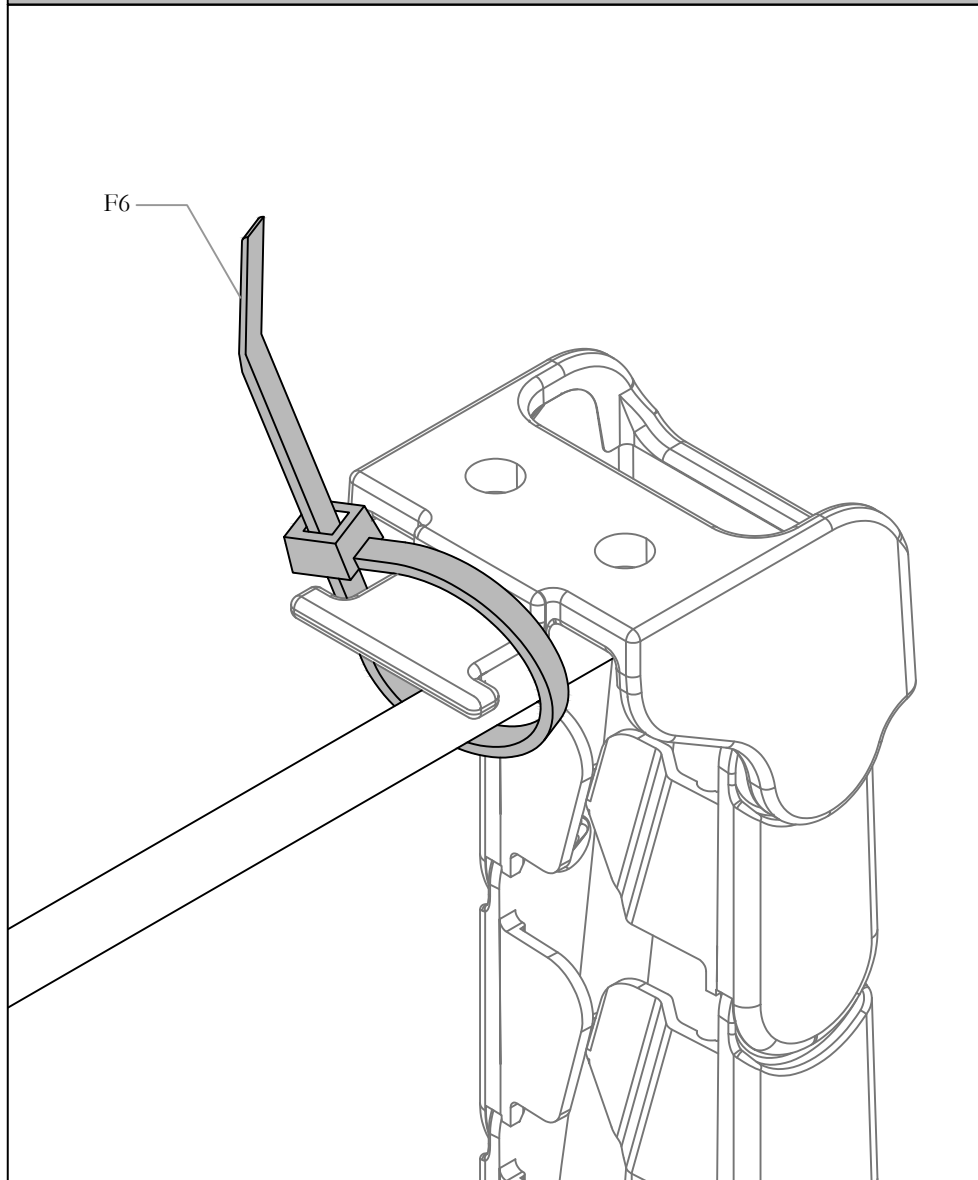

STEP 14: Secure cable to the Wire Carrier using Cable Tie.

WARNING!

Installers must not perform any electrical work while power is on. Care should be taken to test and confirm power is off prior to beginning any assembly and/or disassembly. *Do not connect to power source until installation is complete. *Connection to the building power source must be performed by a licensed electrician. *Failure to follow these instructions poses significant risk of electrical shock, injury and damage. *Only licensed electricians are authorized to make electrical connections in accordance with applicable codes and regulations. *For Teknion Base Feed harnesses, any replacement of the fitting on the hardwired end of the liquidtight whip must be done by a licensed electrician using only fittings approved for the type of liquidtight conduit used on the base feed harness. *Failure to exactly follow these instructions renders Teknion's warranty and safety certifications null and void.

ATTACH TO COVER ASSEMBLY

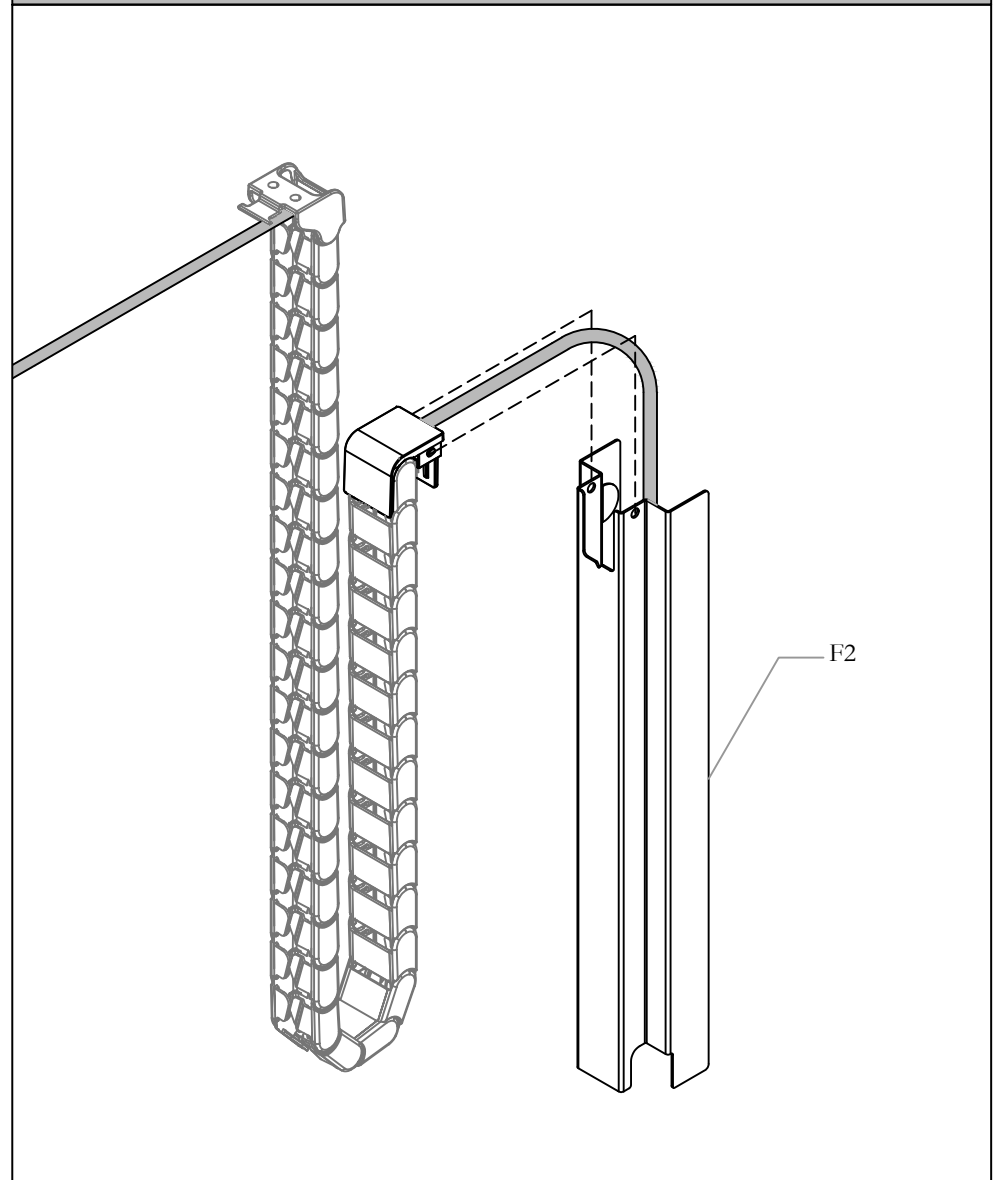

STEP 15: Feed Cable into the Vertical Cover & Pad Assembly before attaching the Wire Carrier as shown and snapping in place.

ATTACH TO LEG

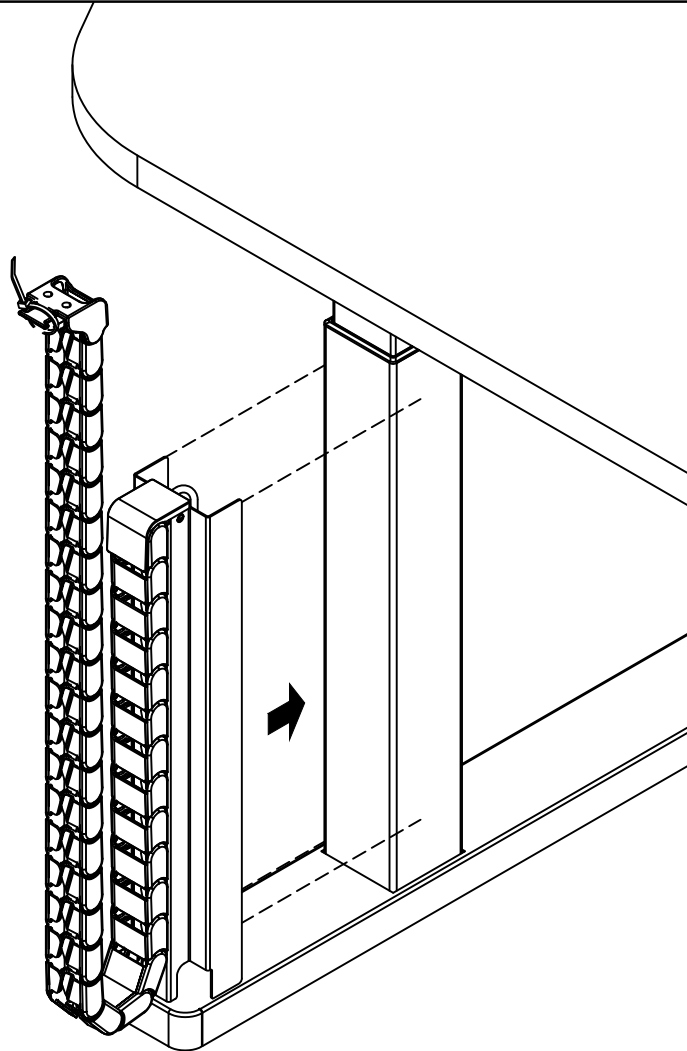

NOTE: Cable hidden for illustration purposes.

STEP 16: Attach Cover to Leg Post of Table as shown.

SECURE TO WORKSURFACE

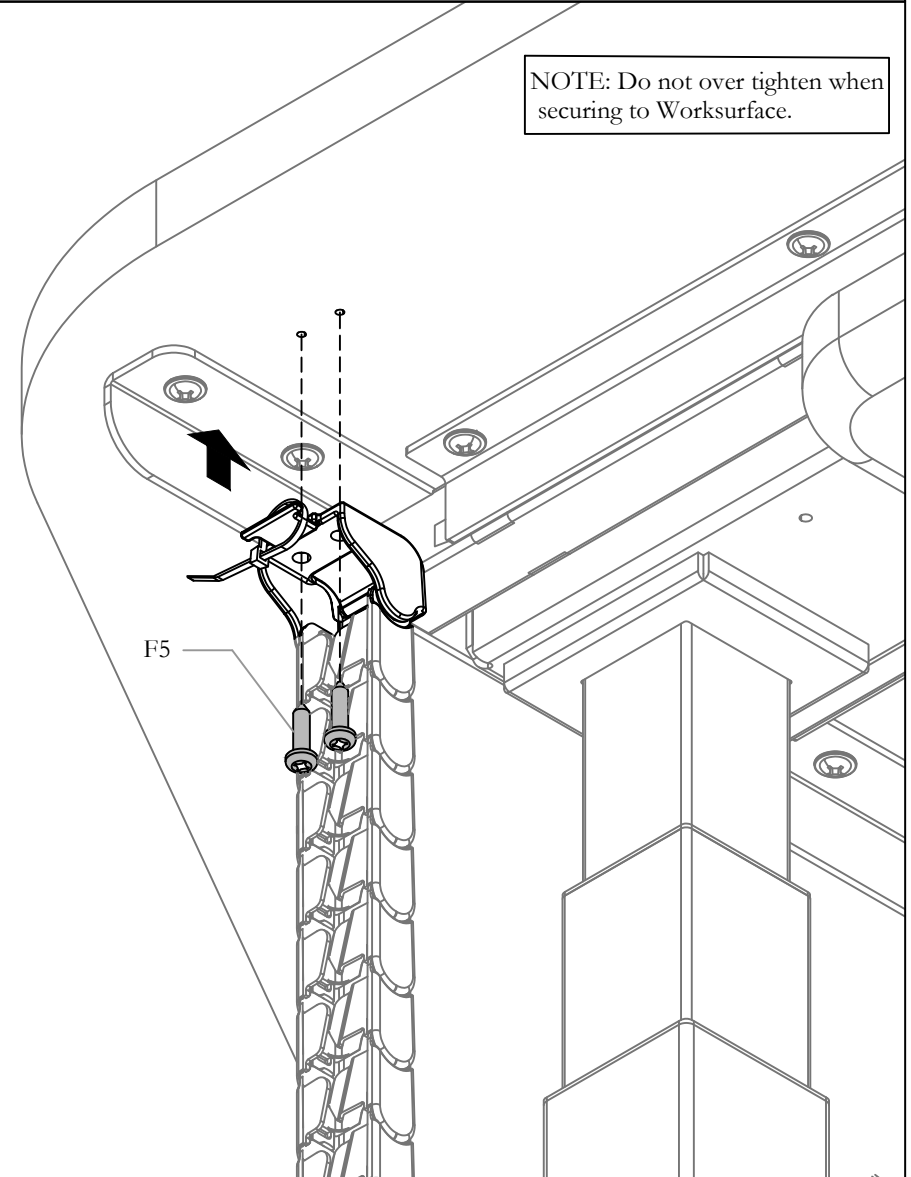

STEP 17: Secure Wire Carrier to underside of Worksurface using designated pilot holes.

Anchor for HA Table (UZAS)

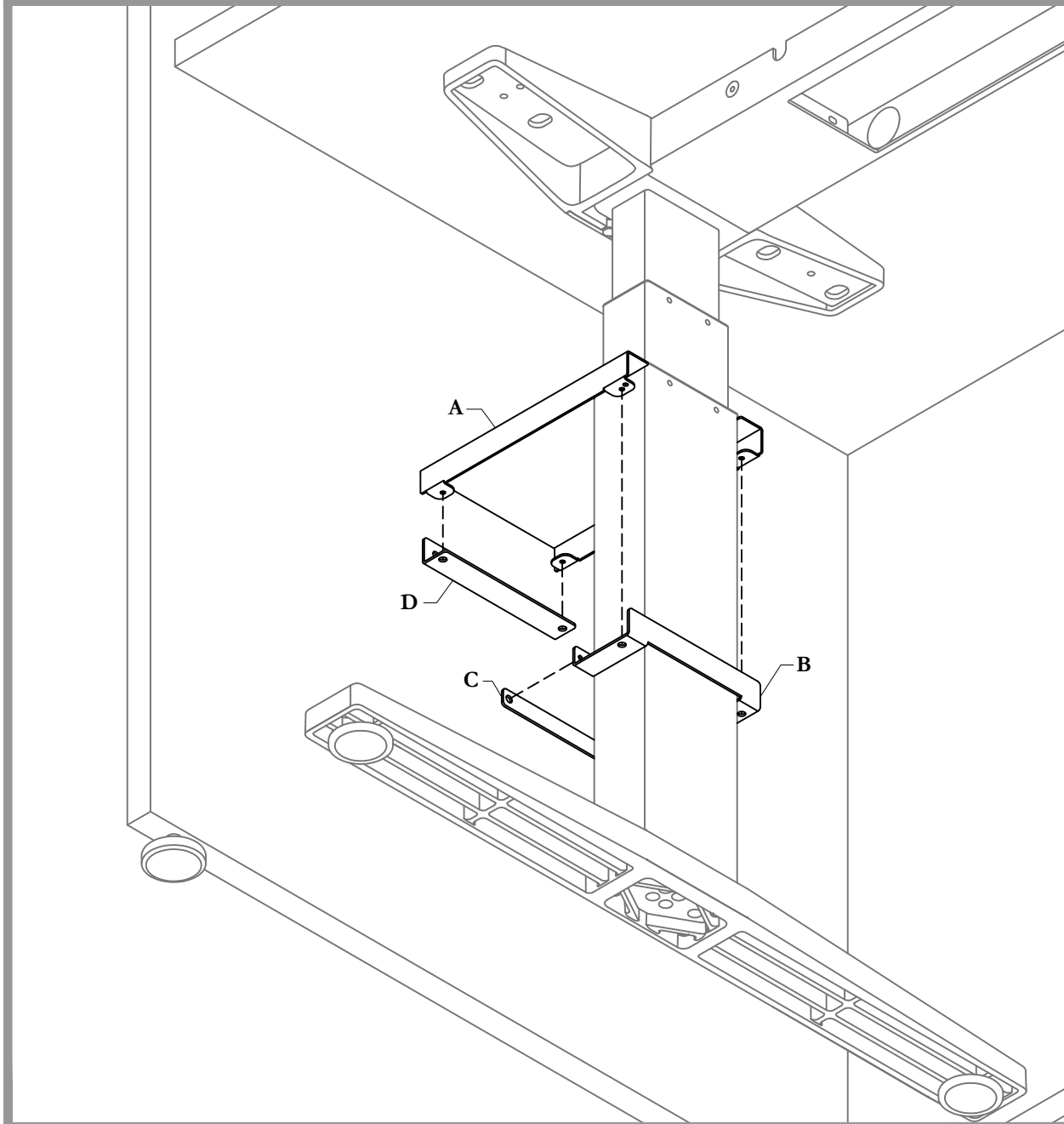

Part and Product Identification

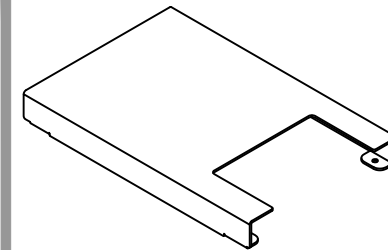

A - Anchor Cover
(A16-12166-X) x1

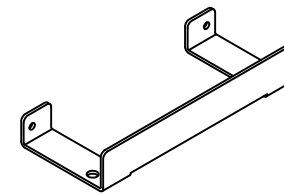

B - Anchor Bracket, HA Leg
(A16-12164-X) x1

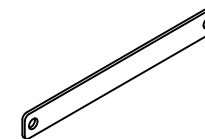

C - Locking Plate
(A16-12170-X) x1

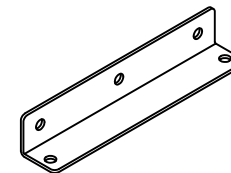

D - Anchor Bracket, Screen
(A16-12165-X) x1



E - 10-32x1/2" Mach Screw
(E01-0535) x6



F - #10 x 0.875" LG. Screw
(E07-0077) x3

ATTACH LEG ANCHOR BRACKET TO LEG

NOTE: UZAS can be used with UZRS/UZRG,
UZCS/UZCG and UNLTS/UNLTG.

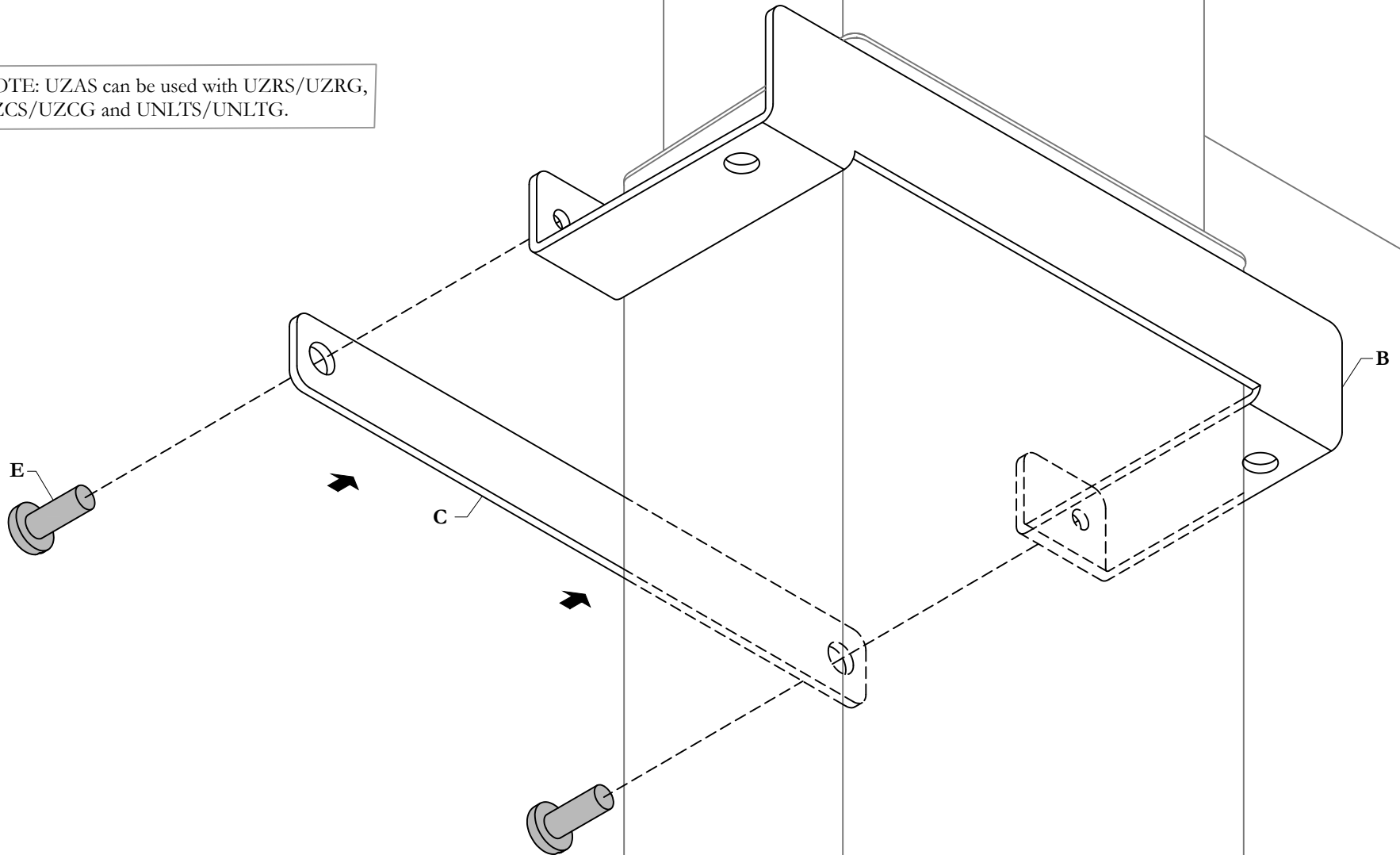

STEP 1: Attach Leg Anchor Bracket to Leg by placing the Bracket around the Leg and attaching the Locking Plate to the Bracket using the provided Screws. Anchor should be installed close to the top of the thickest section of the Height Adjustable Leg.

Section: **ACCESSORIES**

Description: **ANCHOR FOR HA TABLE**

DETERMINE LOCATION OF ANCHOR AND MARK HOLE LOCATION ON SCREEN

$\alpha = 1''$ MIN for UZAS_A or $2''$ MIN for UZAS_B

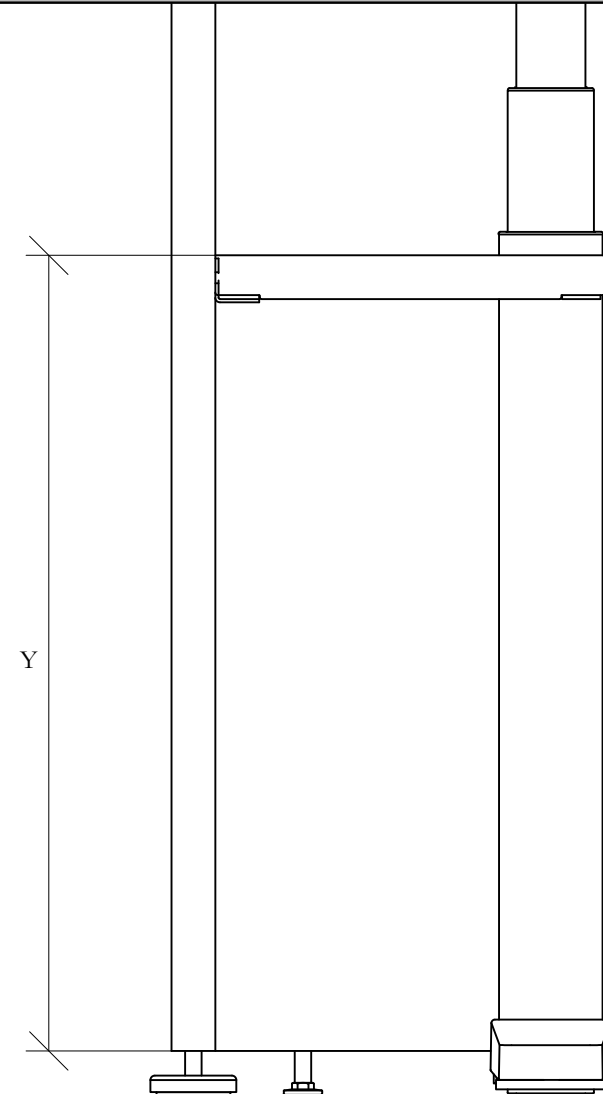
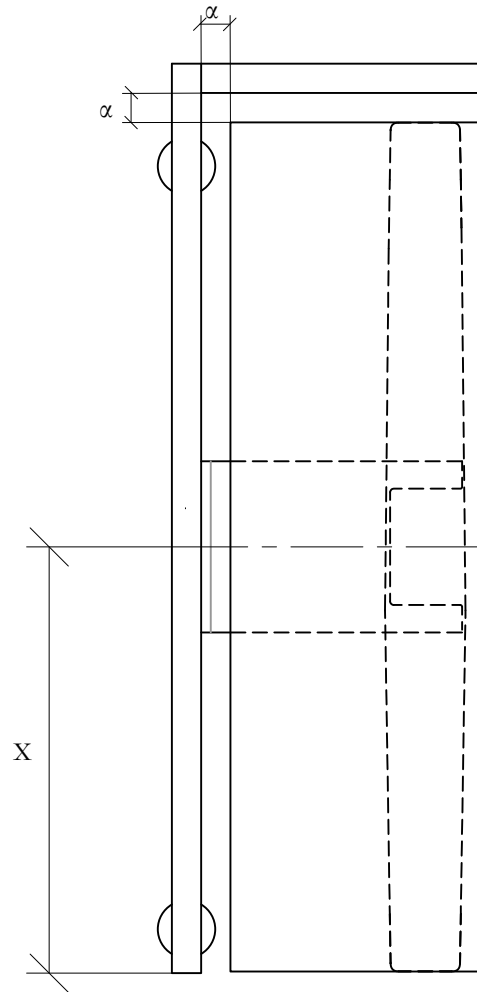

STEP 2: Determine location of Screen Anchor so that the worksurface is 1" from each Screen if no Desk Mount Screen is specified, or 2" from each Screen if the Desk Mount Screen is specified. Once the location of the Anchor is determined mark the location of the holes on the Screen for the Screen Anchor Bracket, ensuring that the bracket remains aligned with the Height Adjustable Leg, Anchor Bracket, and the desired height.

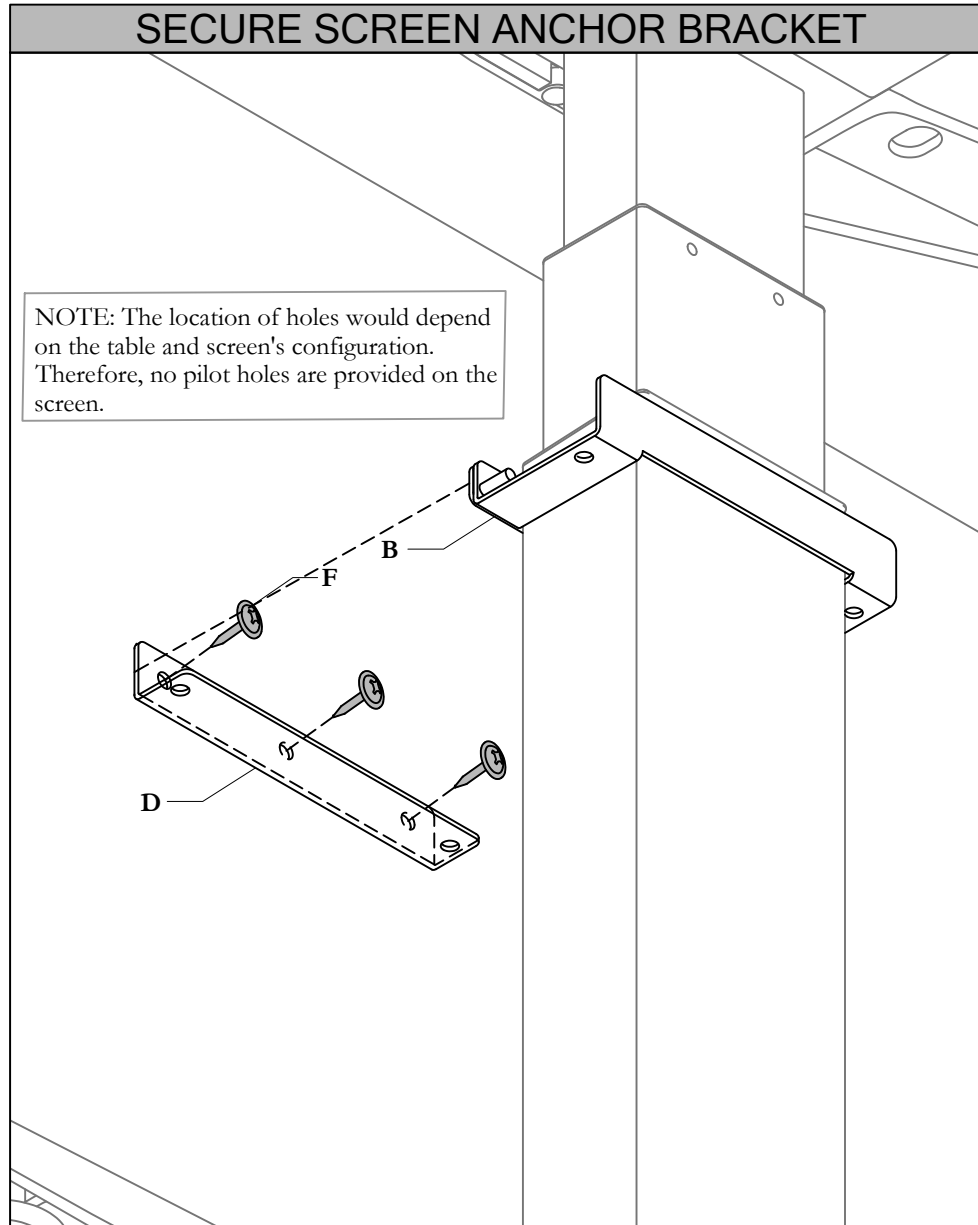

STEP 3: Secure Screen Anchor Bracket to Screen using provided Screws.

The sides and undersides of the two Brackets (B and D) need to be aligned for proper fit

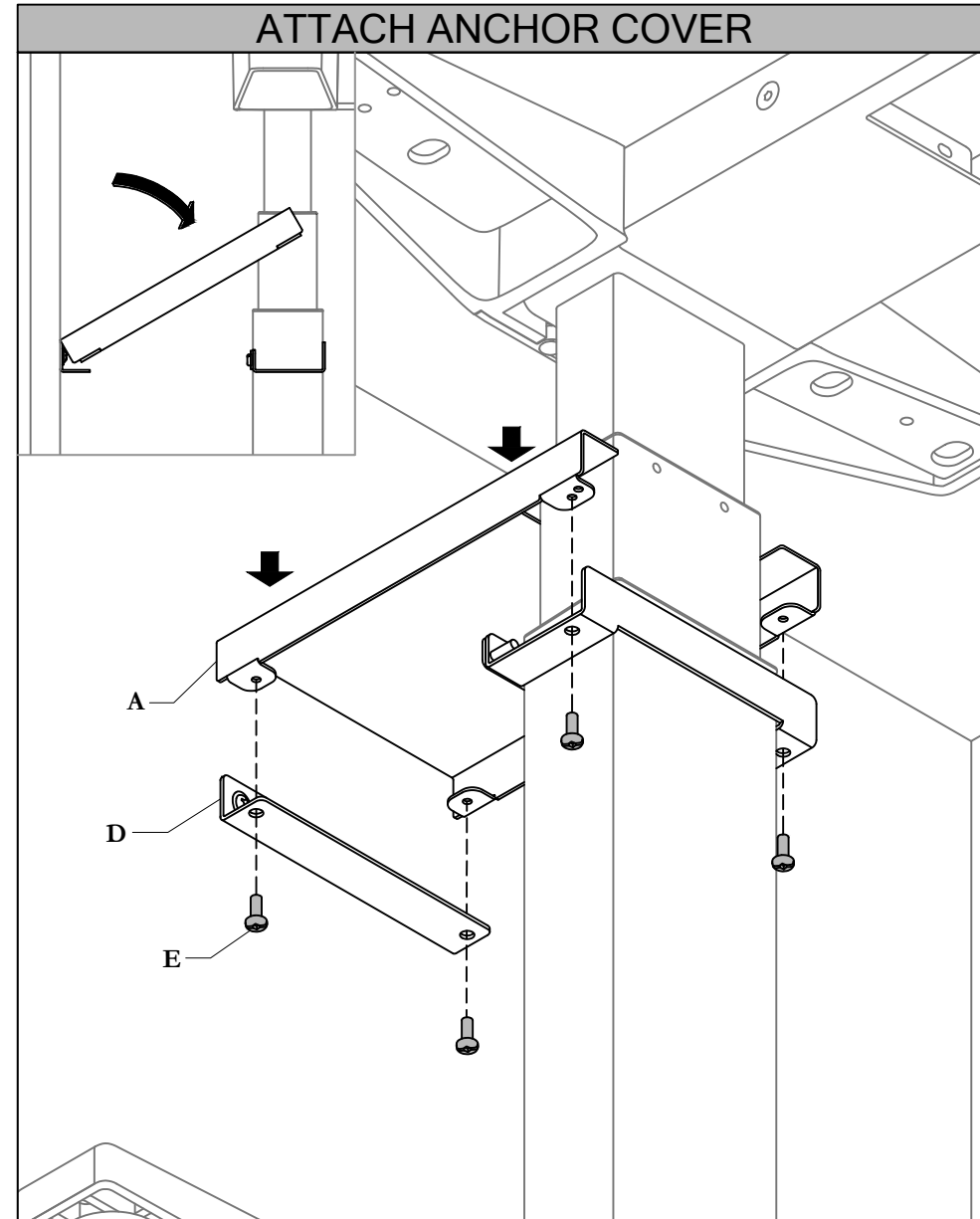

STEP 4: Secure Anchor Cover to Leg Anchor Bracket and Screen Anchor Bracket using provided Screws.

NOTE: To install Anchor Cover angle the Cover between the Screen and Leg and straighten the Cover once it is in the correct location.

Section: **ACCESSORIES**

Date: May 2026 Page No: 5 of 5
DIS_265

Description: **ANCHOR FOR HA TABLE**

FINAL PRODUCT

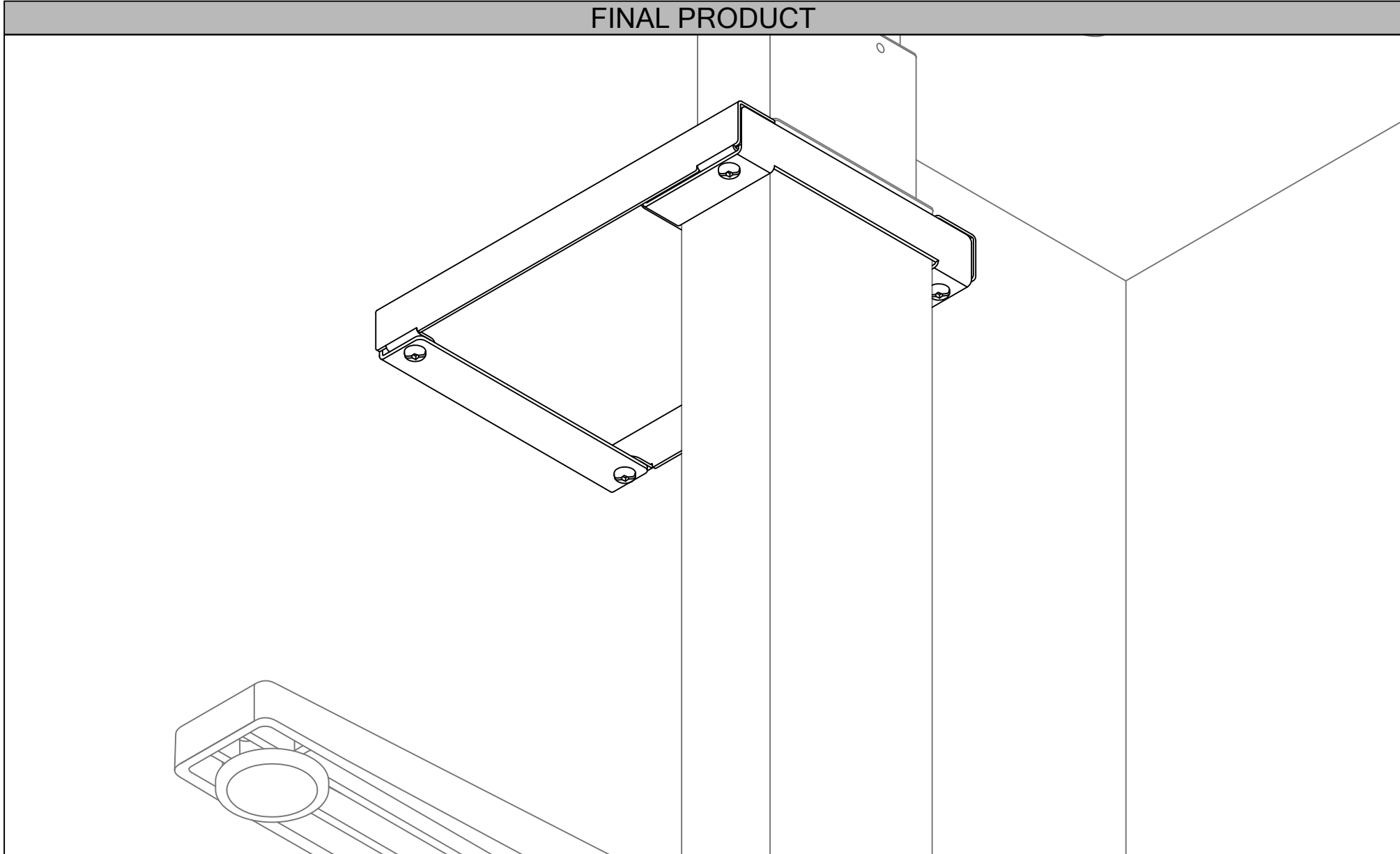

STEP 5: After all parts are assembled the final product should look like this.

Bracket Support for HA Table (UZBS)

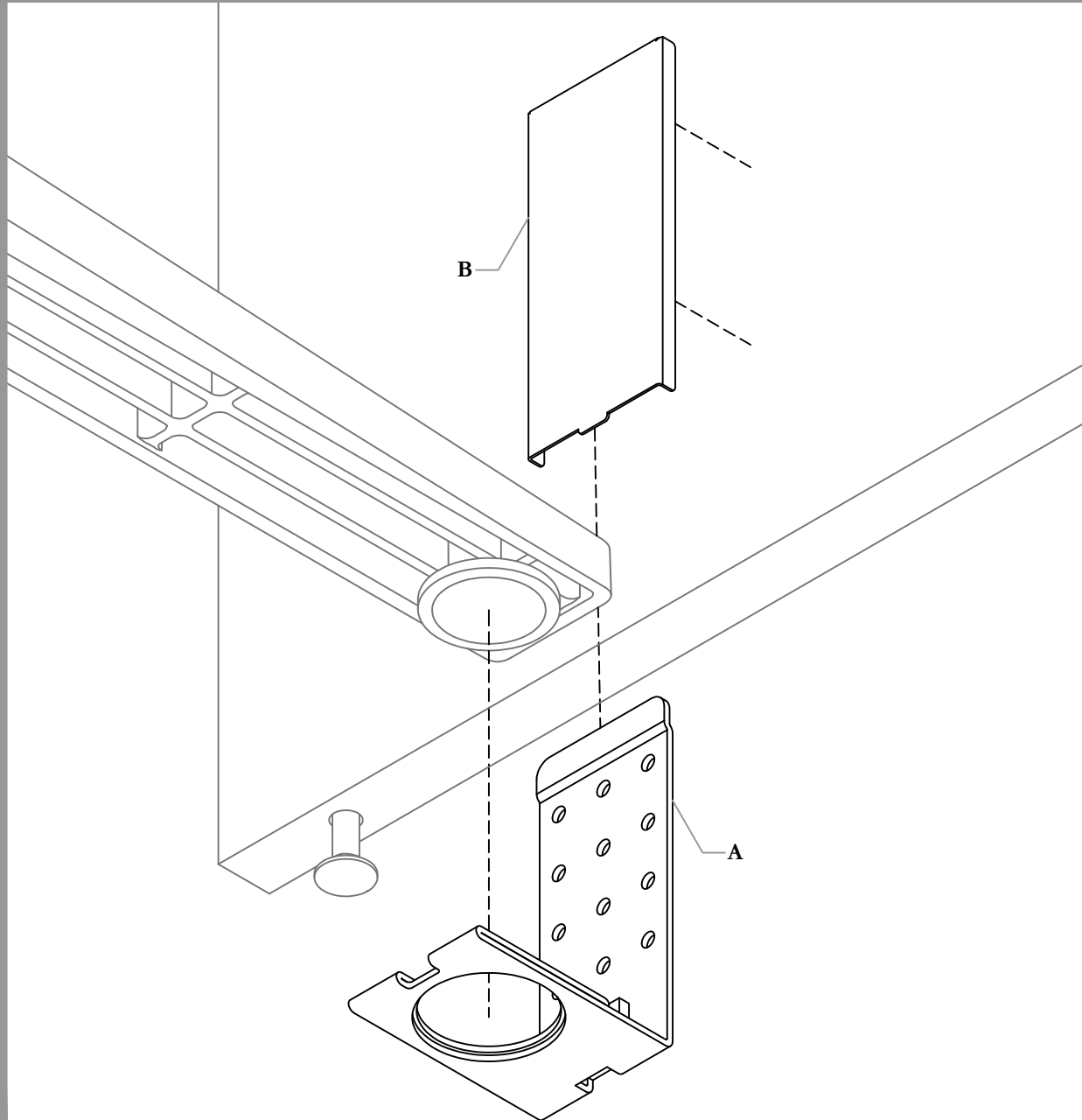

Part and Product Identification

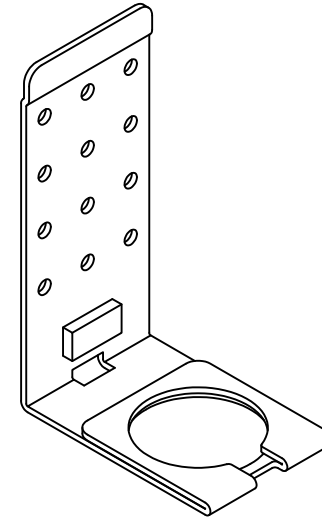

A - Leveler Connection
Bracket Assembly
(N02-6029) x1

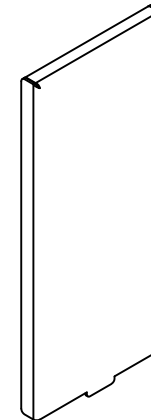

B - Leveler Connection
Bracket Cover
(A16-12163) x1

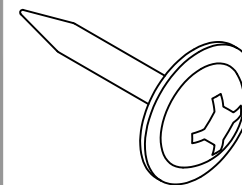

C - #10 - 0.875" Screw
(E07-0077) x4

DETERMINE LOCATION OF HA TABLE

NOTE: UZBS can be used with
UZSS/UZSG and UALSS/UALSG

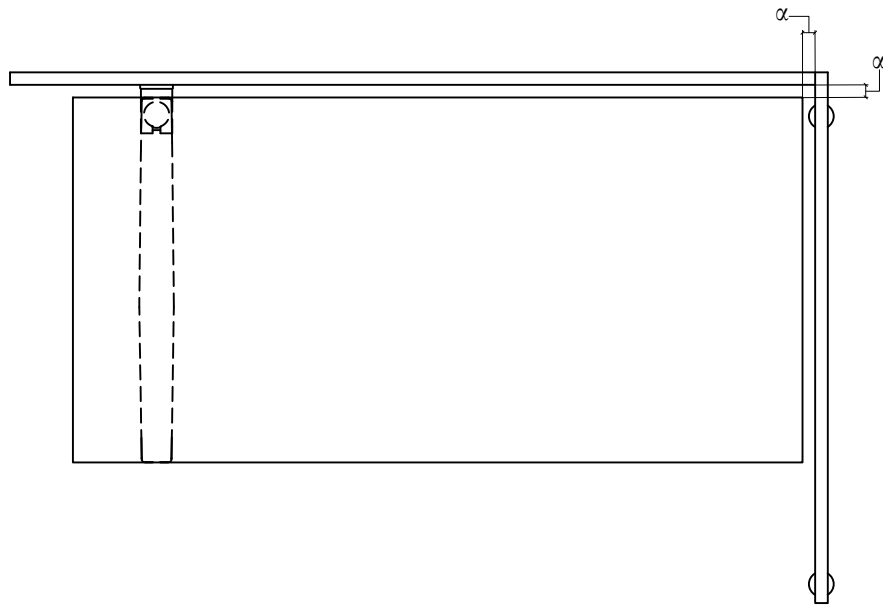

$\alpha = 1''$ MIN for UZBS_A or $2''$ MIN for UZBS_B

STEP 2: Level and place Screen and Table in desired location, maintaining 1" gap for no screen option or a 2" gap for the screen option, around the edges of the worksurface.

PLACE LEVELER ON BRACKET

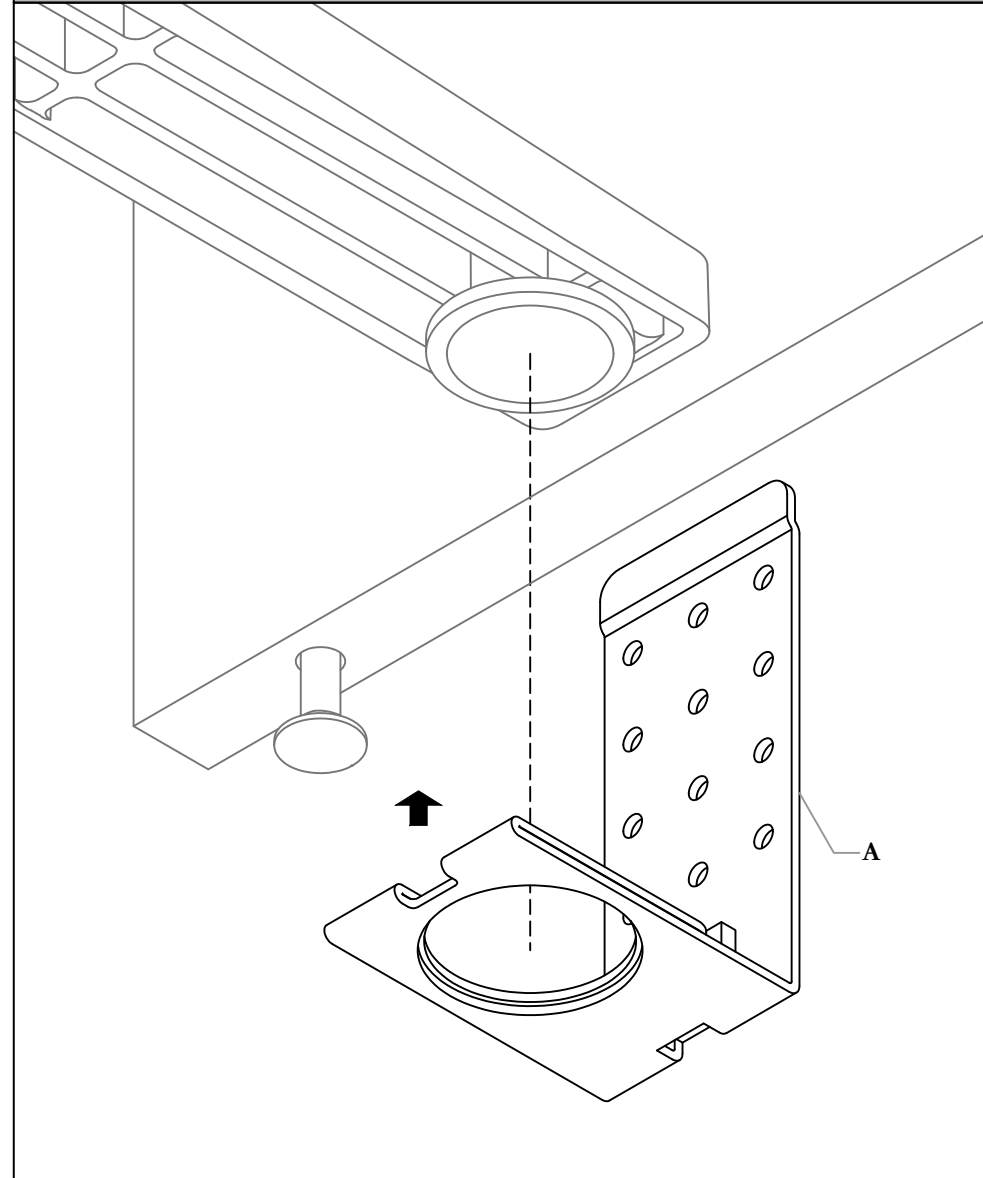

STEP 1: Insert the Bracket (A) in the leveler base.

Section: ACCESSORIES

Description: BRACKET SUPPORT FOR HA TABLE

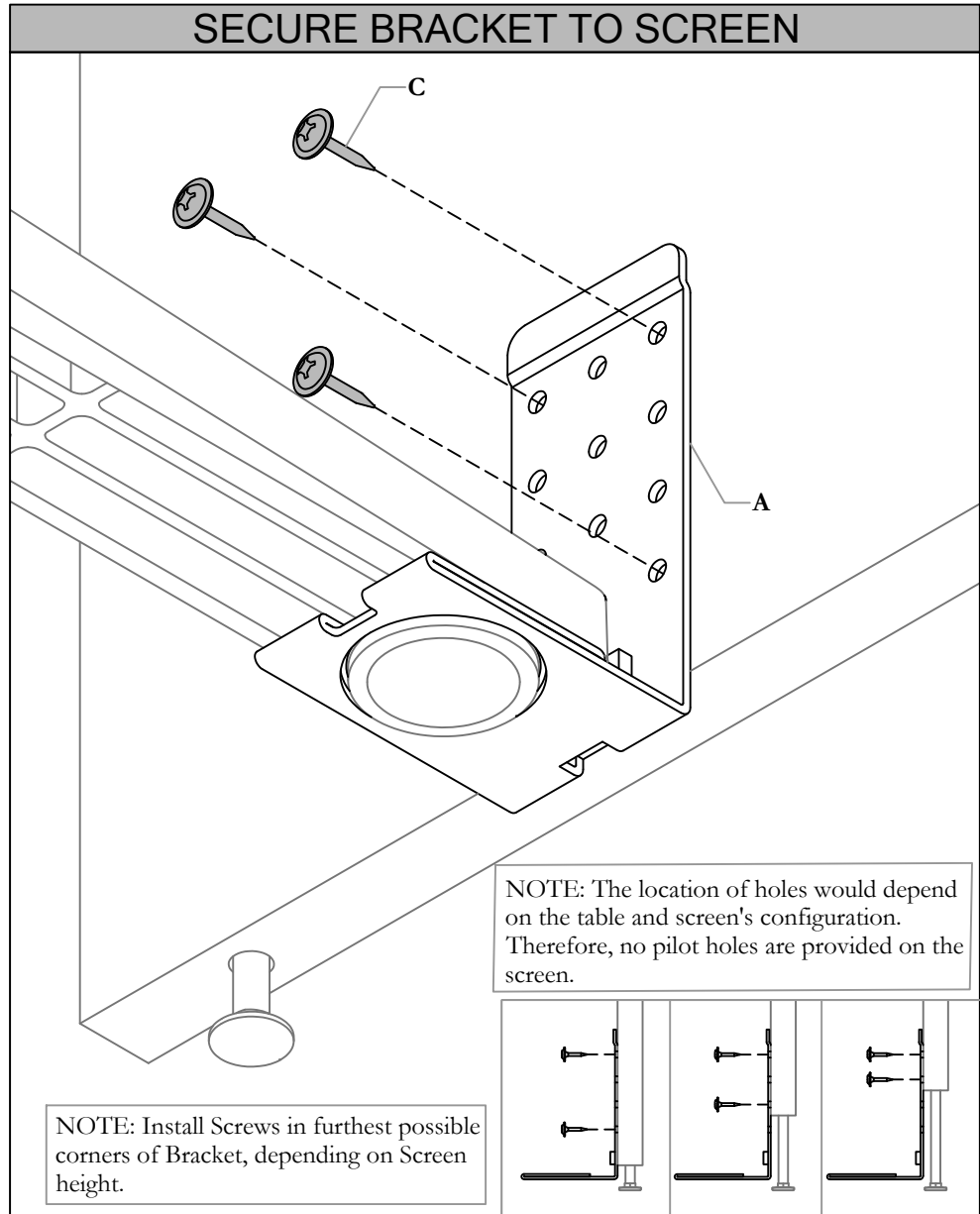

STEP 3: Secure Leveler Connection Bracket to Screen using provided Screws.

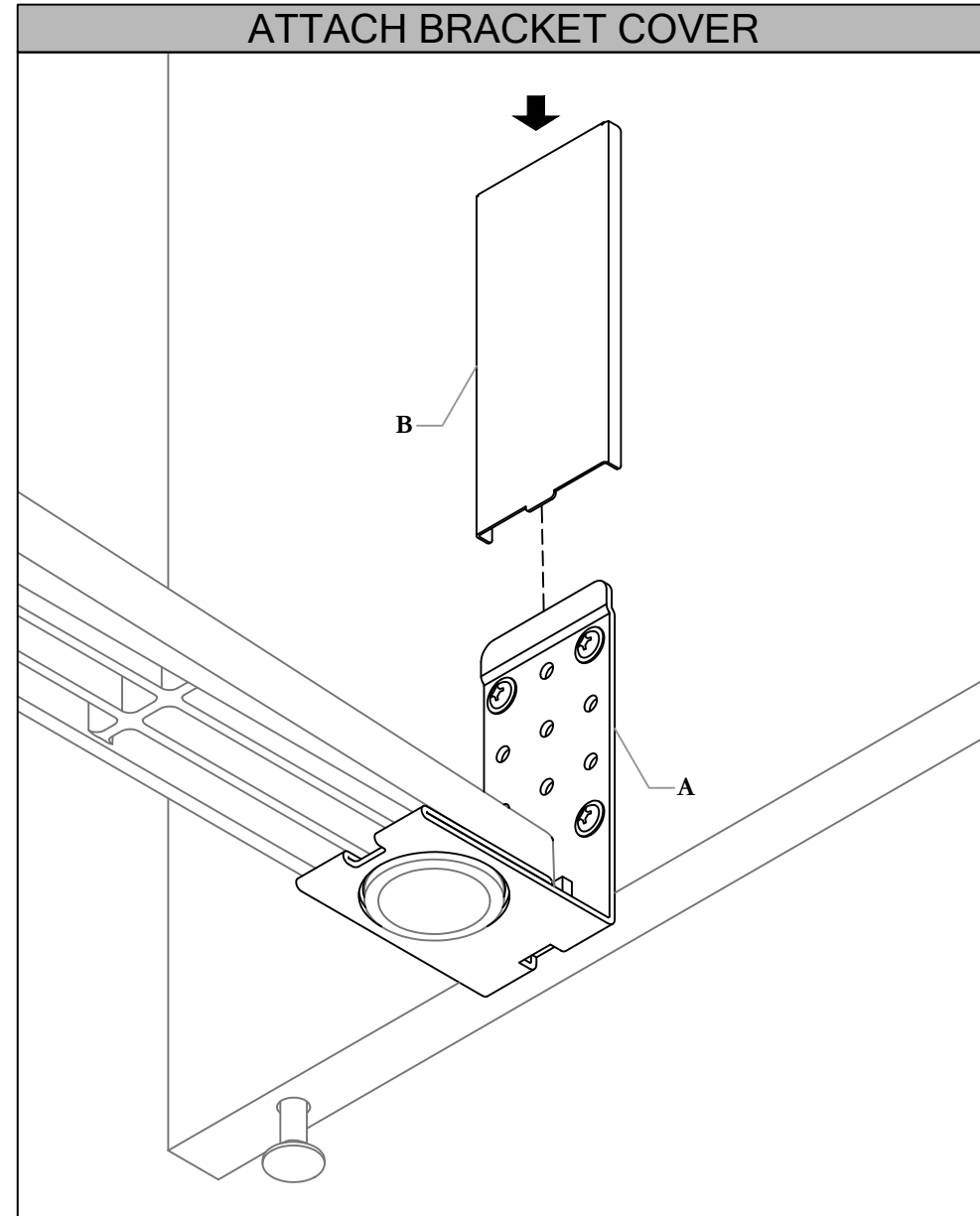

STEP 4: Slide the Cover (B) over top of the Leveler Connection Bracket (A). Ensure the top of Cover (B) is locked in the slot of Bracket (A)

Section: **ACCESSORIES**

Date: May 2026 Page No: 4 of 4
DIS_266

Description: **BRACKET SUPPORT FOR HA TABLE**

FINAL PRODUCT

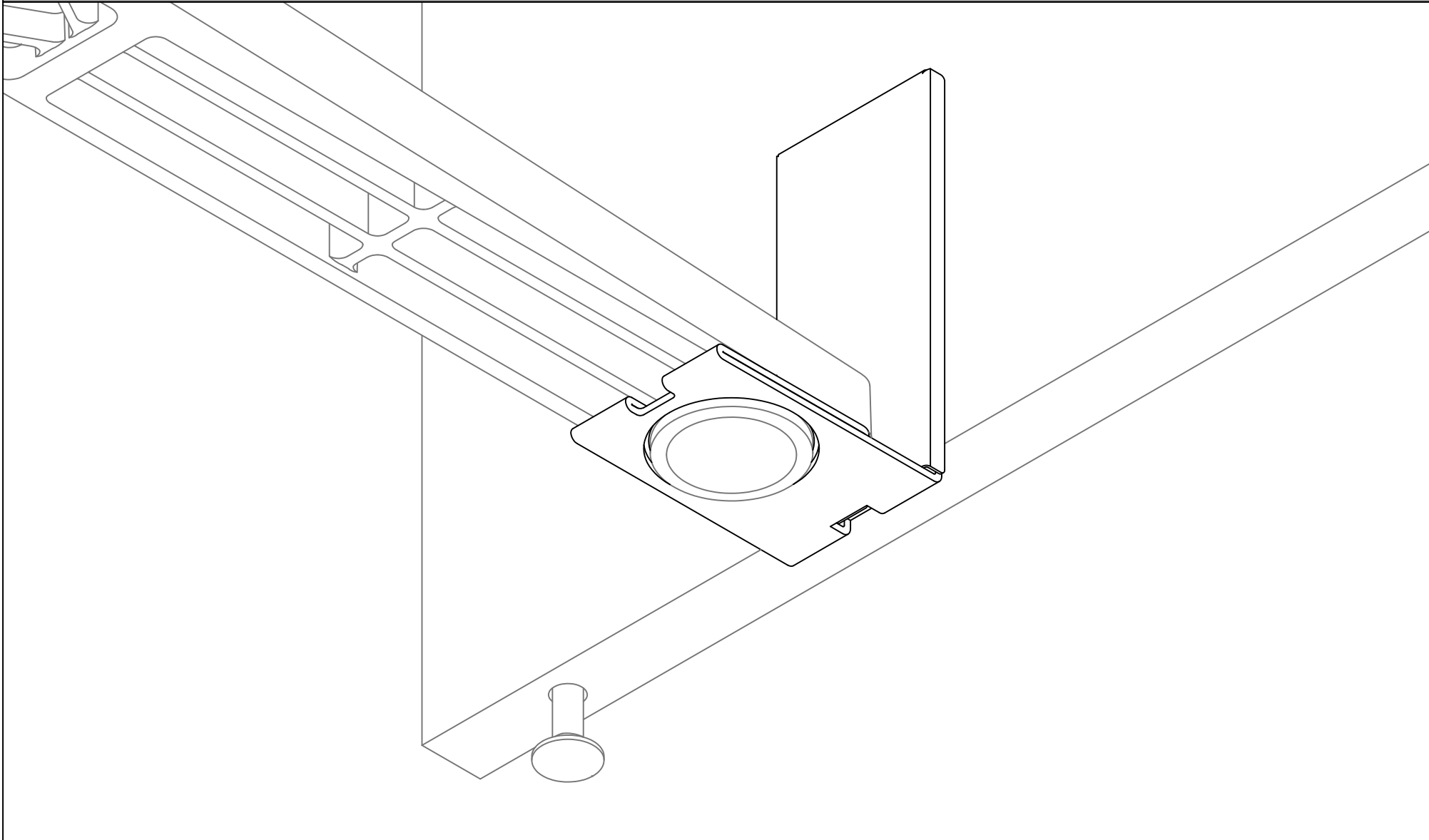

STEP 5: After all parts are assembled the final product should look like this.

Power Spine Base Feed Cover (UZBC)

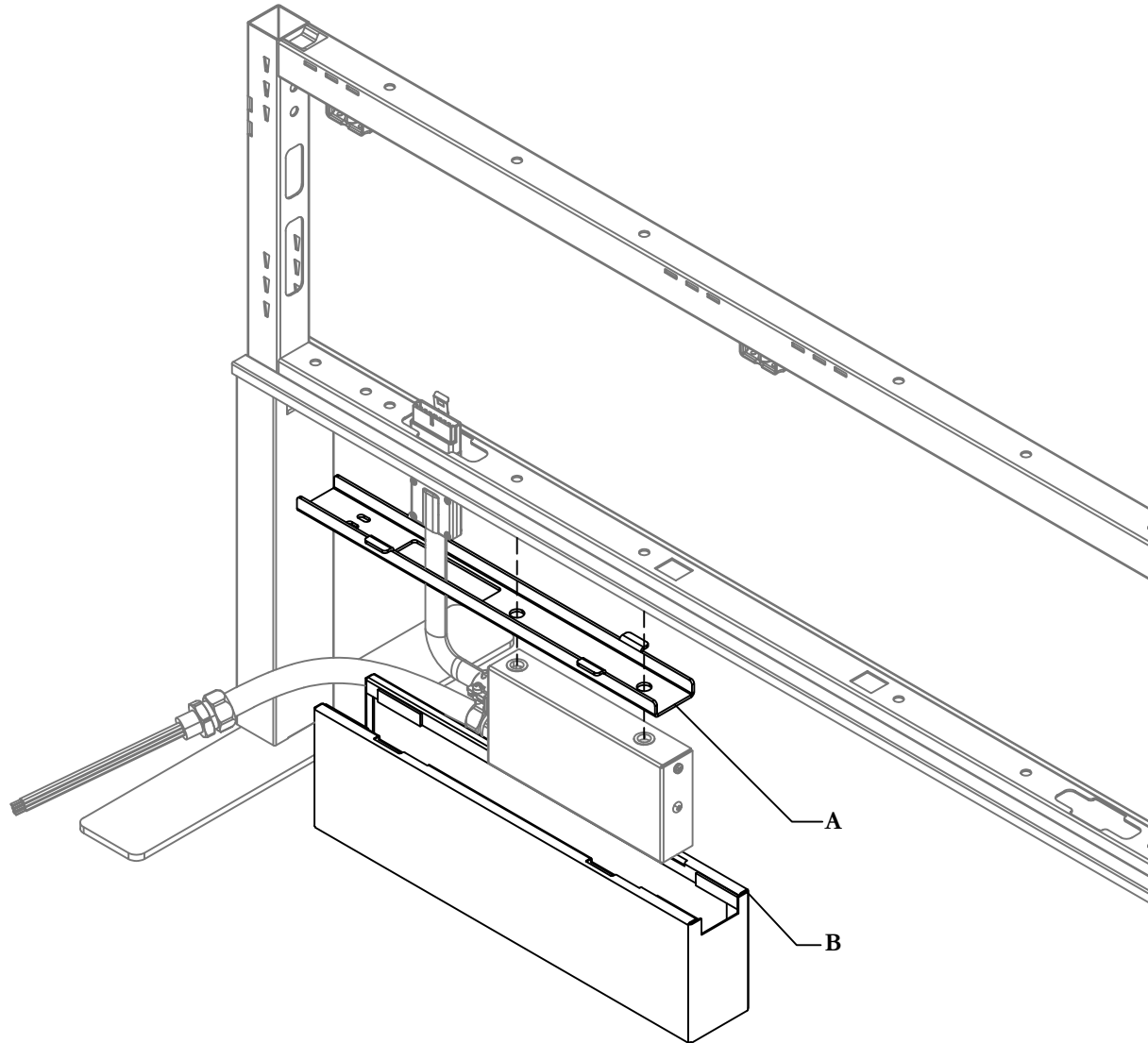

Part and Product Identification

A - Base Feed Cover Top
(A16-9355) x1

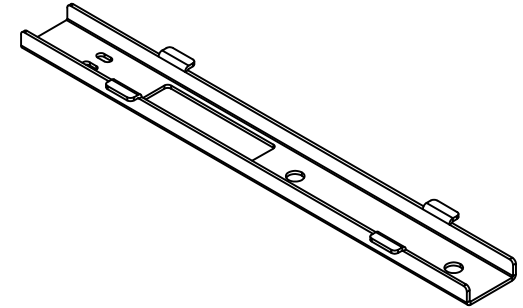

B - Base Feed Weldment
(N01-4731) x1

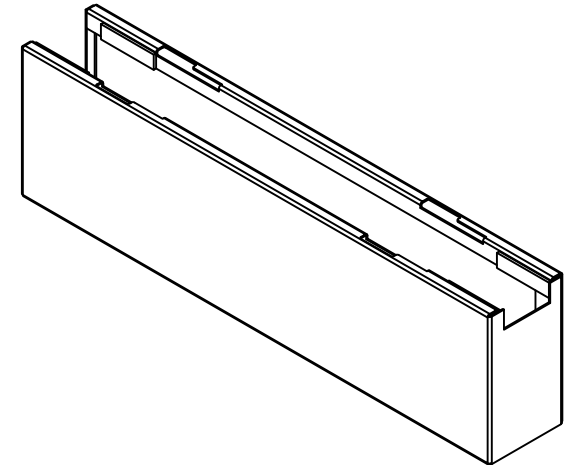

WARNING!

Installers must not perform any electrical work while power is on. Care should be taken to test and confirm power is off prior to beginning any assembly and/or disassembly. Do not connect to power source until installation is complete. Connection to the building power source must be performed by a licensed electrician. Failure to follow these instructions poses significant risk of electrical shock, injury and damage. Only licensed electricians are authorized to make electrical connections in accordance with applicable codes and regulations. For Tekunion Base Feed harnesses, any replacement of the fitting on the hardwired end of the liquidtight whip must be done by a licensed electrician using only fittings approved for the type of liquidtight conduit used on the base feed harness. Failure to exactly follow these instructions renders Tekunion's warranty and safety certifications null and void.

REMOVING BASE FEED

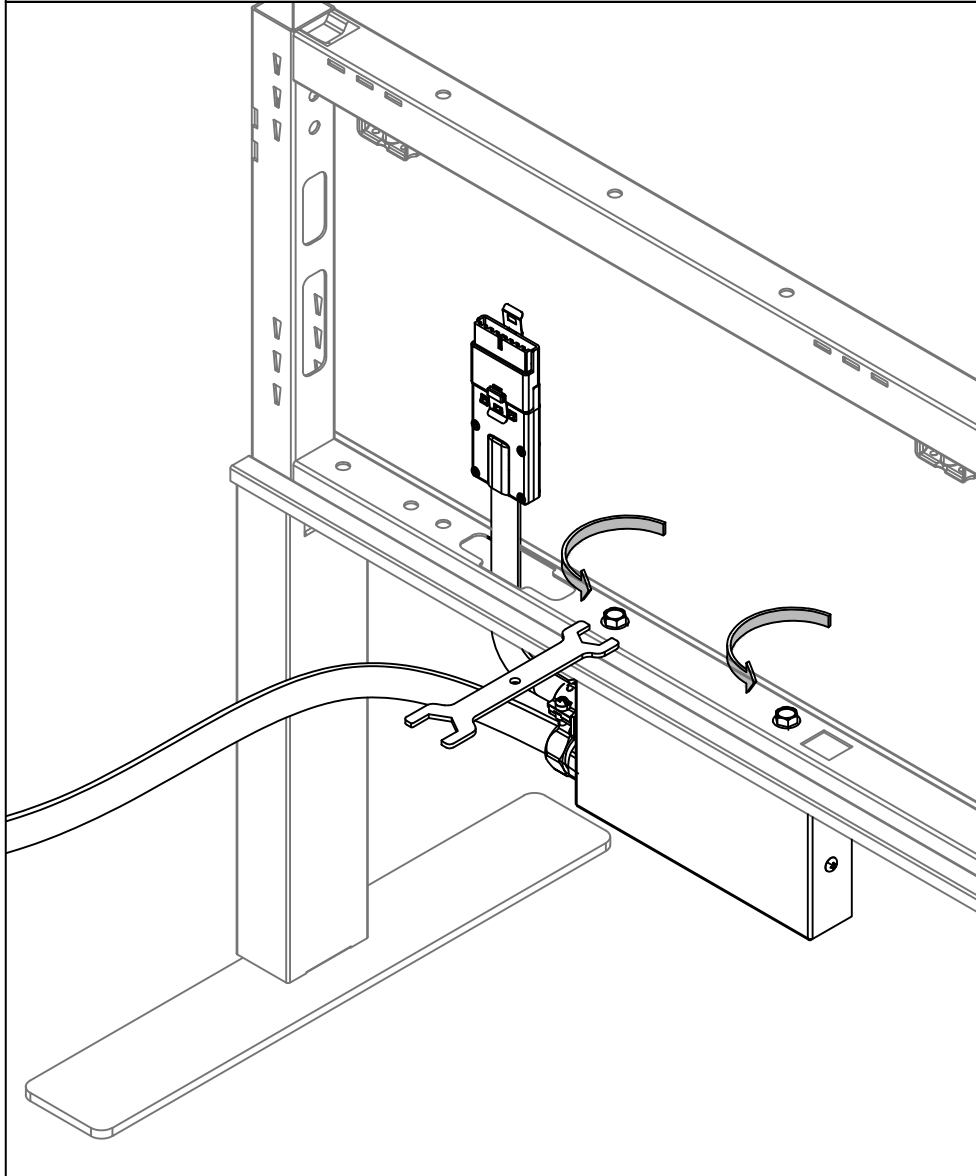

STEP 1: If the base feed is already installed, unscrew the bolts to remove the base feed

INSTALLING BASE FEED TOP COVER

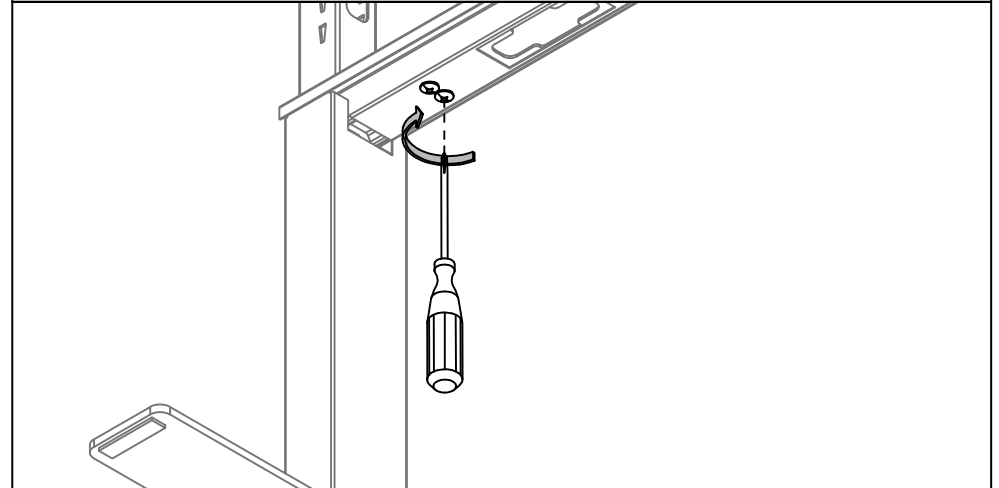

STEP 2: Temporarily remove the 2 screws from the base trim.

INSTALLING BASE FEED TOP COVER

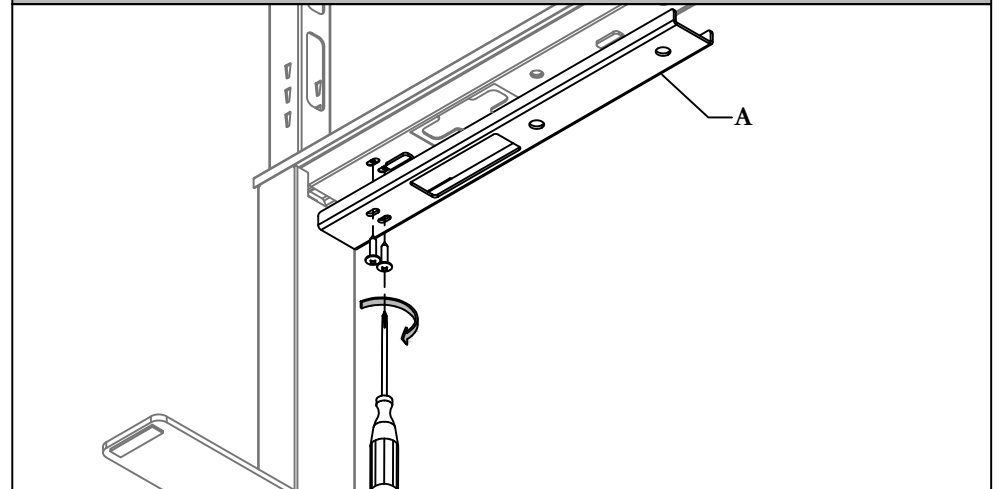

STEP 3: Install the base feed top cover(A) with the base trim using the screws removed in step 2.

SECURING BASE FEED

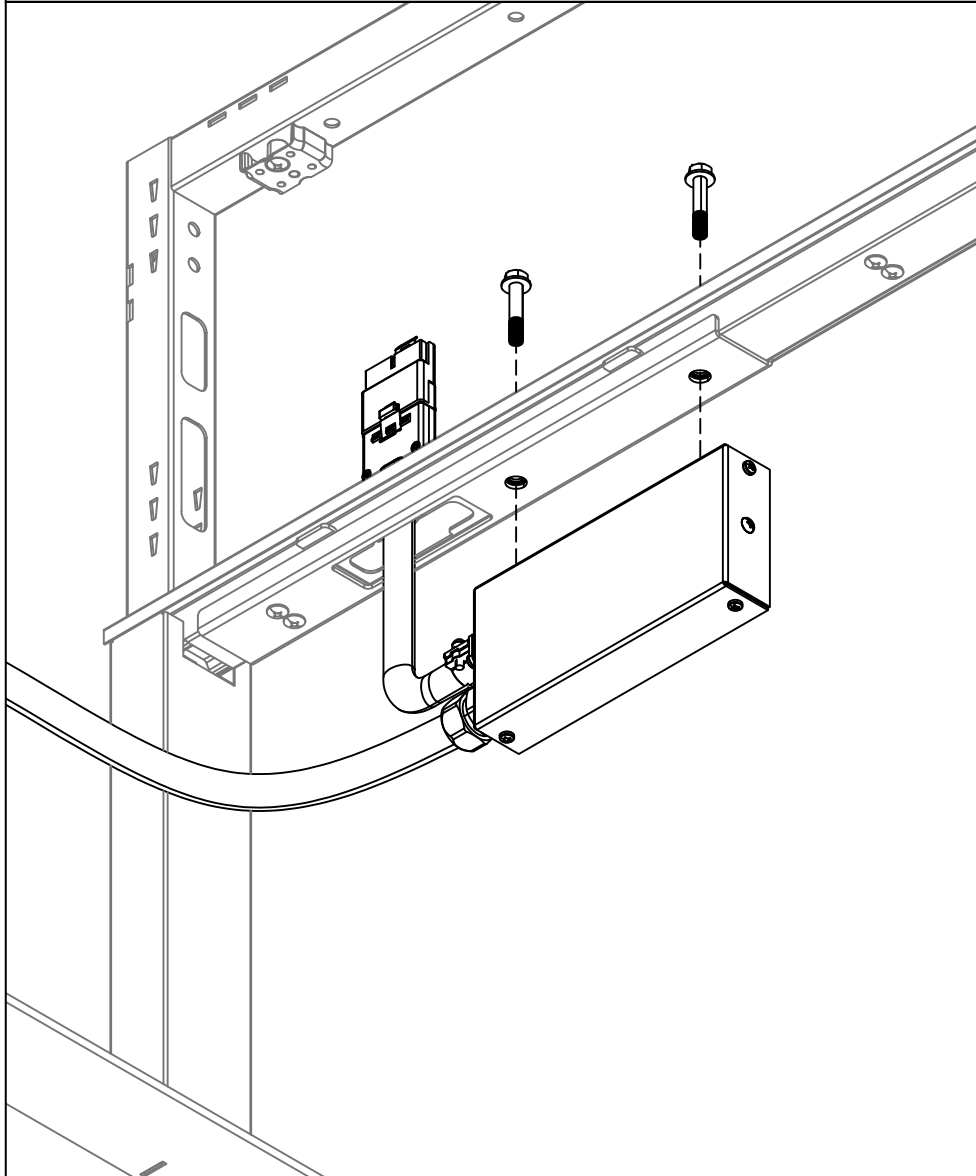

STEP 4: Install the base feed again using the screws.

SECURING WELDMENT

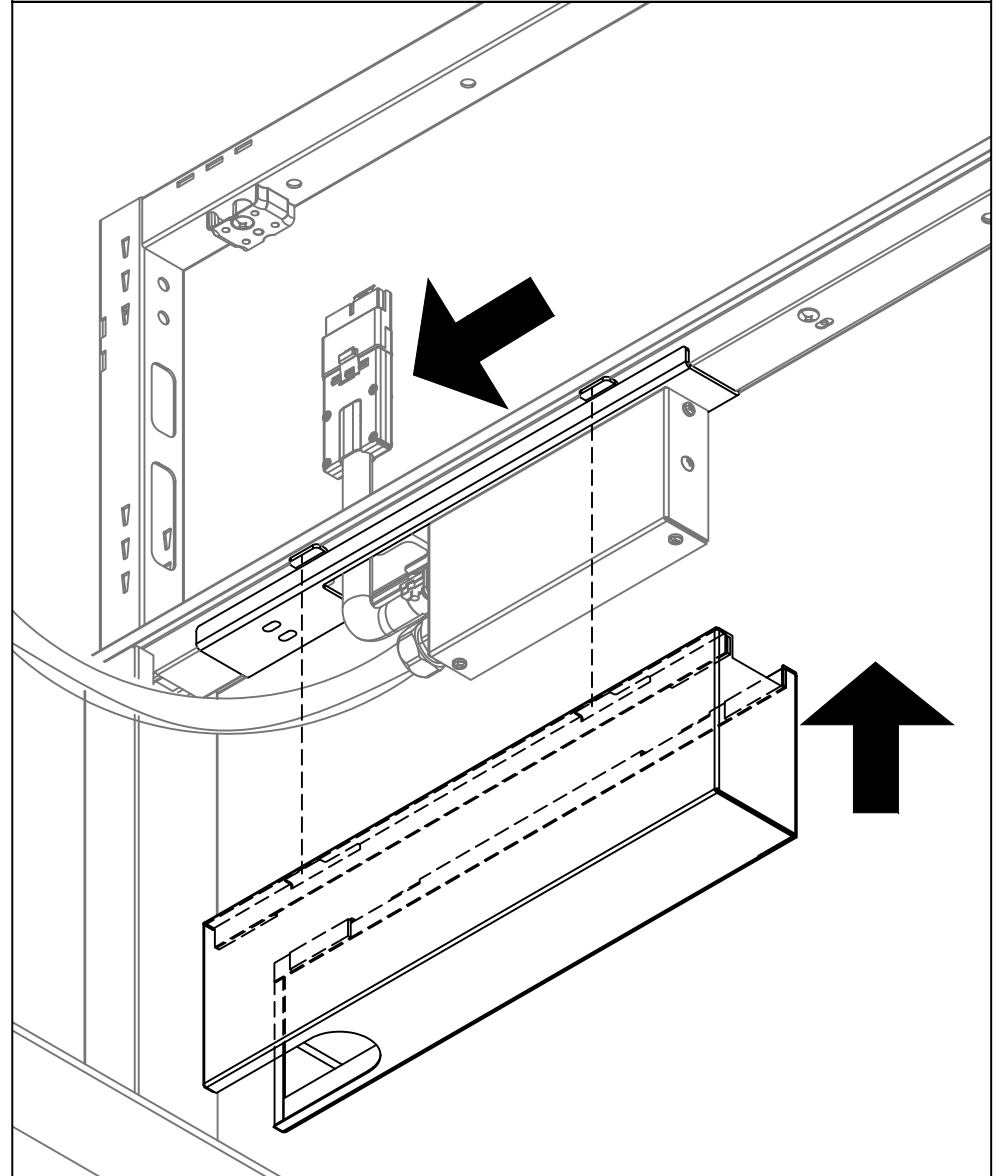

STEP 5: Position the base feed's weldment holes with the notches of the cover top and slide it to right to lock it in its position.